

Proceedings of the Third Interagency Conference on Research in the Watersheds

Planning for an Uncertain Future—Monitoring, Integration, and Adaptation



Scientific Investigations Report 2009–5049



Proceedings of the Third Interagency Conference on Research in the Watersheds

Planning for an Uncertain Future—Monitoring, Integration, and Adaptation

Edited by Richard M.T. Webb and Darius J. Semmens

Scientific Investigations Report 2009–5049

**U.S. Department of the Interior
U.S. Geological Survey**

U.S. Department of the Interior
KEN SALAZAR, Secretary

U.S. Geological Survey
Suzette M. Kimball, Acting Director

U.S. Geological Survey, Reston, Virginia: 2009

For product and ordering information:
World Wide Web: <http://www.usgs.gov/pubprod>
Telephone: 1-888-ASK-USGS

For more information on the USGS—the Federal source for science about the Earth,
its natural and living resources, natural hazards, and the environment:
World Wide Web: <http://www.usgs.gov>
Telephone: 1-888-ASK-USGS

The manuscripts and abstracts of U.S. Geological Survey authors were reviewed and approved for publication by the U.S. Geological Survey. Articles submitted by university researchers and other Department of the Interior agencies did not go through the U.S. Geological Survey review process, and therefore may not adhere to our editorial standards or stratigraphic nomenclature. However, all articles were edited for consistency in appearance in the published proceedings. The use of trade names in any article does not constitute endorsement by the U.S. Geological Survey.

Suggested citation:
Webb, R.M.T., and Semmens, D.J., eds., 2009, Planning for an uncertain future—Monitoring, integration, and adaptation. Proceedings of the Third Interagency Conference on Research in the Watersheds: U.S. Geological Survey Scientific Investigations Report 2009-5049, 292 p.

Any use of trade, product, or firm names is for descriptive purposes only and does not imply endorsement by the U.S. Government.

Although this report is in the public domain, permission must be secured from the individual copyright owners to reproduce any copyrighted material contained within this report.

Preface

Richard M.T. Webb and Darius J. Semmens

These proceedings contain the presentations, discussions, and recommendations of the 91 participants of the Third Interagency Conference on Research in the Watersheds convened in Estes Park, CO, 8–11 September 2008.

Keywords: climate change, sustainable ecosystems, watershed management

If we learn, finally, that what we need to 'manage' is not the land so much as ourselves in the land, we will have turned the history of American land-use on its head.

—Senator Gaylord Nelson, Founder of Earth Day*

The 6.7 billion human inhabitants of the earth have the ability to drastically alter ecosystems and the populations of species that have taken eons to evolve. By better understanding how our actions affect the environment, we stand a better chance of designing successful strategies to manage ecosystems sustainably. Toward this end, the Third Interagency Conference on Research in the Watersheds (ICRW) was convened in Estes Park, CO, on September 8–11, 2008.

The Conference provided a forum to present adaptive management as a practical tool for learning how to manage complex ecosystems more sustainably. Further complexity introduced by spatially variable and continuously changing environmental drivers favors this management approach because of its emphasis on adaptation in response to changing conditions or ineffective actions. For climate change in particular, an adaptive approach can more effectively accommodate the uncertainty in future climate scenarios.

Scenarios compiled by the Intergovernmental Panel on Climate Change are built on distinct economic, energy, and societal models. The scenarios predict potential changes in greenhouse gases, temperature, precipitation, and atmospheric aerosols, which would

have direct or indirect impacts on the timing, volume, and quality of runoff, vegetation, snowpack, stream temperature, groundwater, thawing permafrost, and icecaps.

Through presentations and field trips, researchers and stakeholders described how their findings and issues fit into the adaptive management 'learning by doing' paradigm of Assess > Design > Implement > Monitor > Evaluate > Adjust > Assess.

Watersheds are the primary planning unit being used for resource management and the natural unit for research studies on surface water hydrology and water quality. A goal for all ICRW conferences is to bring together researchers working at the watershed scale and stakeholders living and working in the watersheds. The Third ICRW was hosted by the U.S. Geological Survey (USGS) and the Consortium of Universities for the Advancement of Hydrologic Science, Inc. (CUAHSI), with contributions from the Environmental Protection Agency, the Department of Agriculture (Agricultural Research Service; Natural Resource and Conservation Service; U.S. Forest Service), the Department of Interior (National Park Service; Bureau of Reclamation; U.S. Fish and Wildlife Service), and the National Oceanic and Atmospheric Administration. The conference was convened in Estes Park with 91 scientists, water managers, policy makers, and local stakeholders.

In recognition of the difficulties associated with maintaining focus for such a diverse group of participants on such a broad range of topics, two preconference workshops were held on Sunday and Monday, September 7–8. The first workshop focused on Collaborative Competencies, facilitated by Todd Bryan, Senior Associate with the Keystone Center, Glendale Springs, CO, and the second on Adaptive Management, facilitated by Ken Williams, Chief of Cooperative Programs, USGS, Reston, VA.

Eric Kuhn, General Manager of the Colorado River Conservation District, provided the keynote welcome speech on Monday evening. He explained the uncertainties and unresolved legal disputes involved

* Nelson, G. 1994. Foreword. In D. Zaslowsky, T.H. Watkins, and The Wilderness Society, *These American Lands: Parks, Wilderness, and the Public Lands*, p. xv. Island Press, Washington DC.

with “the law of the river,” the complex and often conflicting compacts, treaties, and Federal and State statutes that apply to those who share the Colorado River’s wealth among the states of Arizona, California, Colorado, New Mexico, and Utah and the Republic of Mexico. Kuhn said, “New tools will be needed as we transition from the era of development to a new era of uncertainties.” He said that within the Colorado River Basin there are three major sources of uncertainty: hydrology, demands, and unresolved legal disputes. Climate change brings in even more uncertainty, suggesting a future with less streamflow. Current climate science suggests that the southwestern United States and lower elevation watersheds will be most susceptible to impacts of climate change. To help manage these uncertainties, he suggested three broad strategies: (1) early identification of unacceptable outcomes; (2) maintenance of positive relationships among stakeholders; and (3) better integration of science into decisionmaking.

A series of overview talks opened the Tuesday plenary sessions. Following the plenary sessions, participants split into four regional tracks: Arid West, Interior Temperate and Boreal, Low Latitudes and Maritime, and National. For each track, descriptions of research progressed through climate, geology, geomorphology, hydrology, biogeochemistry, ecology, human impacts, and management. Equal time was allotted to presentations and subsequent facilitated discussions of the research presented in terms of its position within the adaptive management framework.

Field trips on Wednesday highlighted collaborative ecological research in Rocky Mountain National Park and Niwot Ridge, a long-term ecological research station.

On Wednesday night two top researchers were recognized. Tom Winter of the U.S. Geological Survey was presented an ‘Insight Award’ for his outstanding contributions to science-driven watershed management. Susan Moran of the Agricultural Research Service was recognized with a ‘Founder’s Award’ in recognition of her outstanding vision and leadership in establishing the Interagency Conference on Research in the Watersheds.

The conference concluded on Thursday morning with a plenary session describing specific applications of adaptive management at the watershed scale followed

by an open discussion of lessons and suggestions, some of which included:

- The adaptive management paradigm is the familiar scientific method with management used as a treatment.
- Most global climate models predict increasing temperatures for the next century, resulting in greater potential evapotranspiration and greater water-holding capacity of the atmosphere. Water managers should therefore plan for drier soils and greater variability in the weather, i.e. bigger floods and extended droughts.
- Adaptive management is well suited for watersheds with difficult issues, competing interests, and uncertain models of how the system will respond to a given management approach. Stakeholder buy-in is critical for success, as are necessary institutional changes.
- Scientists and managers have different backgrounds and purposes. Asking scientists to place their research in the context of management is like trying to force a square peg into a round hole. Similarly, managers are unclear as to the role of open-ended, curiosity driven research in the short-term management of watersheds. Co-location of scientists and resource managers, as practiced by some management agencies, would enhance science-driven management in complex watersheds. In the long run, existing bureaucracies and management approaches will need to be overhauled if adaptive management is to become a standard approach in watershed management .
- The time needed to travel through one revolution of the adaptive management paradigm—Assess > Design > Implement > Monitor > Evaluate > Adjust > Assess—is much less for issues confronting local and regional watersheds with a limited number of goals and stakeholders than it is for national or global environmental issues where policies, science, and the needs of stakeholders are more complex.
- Two immediate needs were identified: (1) the use of social scientists, similar to agricultural extension agents, as liaisons between the managers and stakeholders in the watershed and the scientists and policy makers who can

be out of touch with local issues and conditions; and (2) more accurate downscaling of coarse global climate models to finer resolutions needed by municipal and regional managers of watersheds and ecosystems.

The Fourth ICRW will be hosted by the Bureau of Land Management in Fairbanks, AK, home to multiple agencies looking at how to best manage ecosystems actively responding to current warming trends. Updates will be made available on the conference website <http://www.hydrologicscience.org/icrw/>.

Acknowledgments

The following individuals, listed in alphabetical order, contributed their time and effort to making the conference a success:

Steering Committee

Jill Baron, U.S. Geological Survey
Ben Blaney, Environmental Protection Agency
Levi Brekke, Bureau of Reclamation
Don Campbell, U.S. Geological Survey
Dave Clow, U.S. Geological Survey
Dick "Randy" Fowler, U.S. Forest Service
Earl Greene, U.S. Geological Survey
Deborah Hayes, U.S. Forest Service
Rick Hooper, Consortium of Universities for the
Advancement of Hydrologic Science, Inc.
Leo House, U.S. Geological Survey
Bob Jarrett, U.S. Geological Survey
Jim Kircher, U.S. Geological Survey
Jason Krutz, Agricultural Research Service
Susan Moran, Agricultural Research Service
Pete Murdoch, U.S. Geological Survey
Jim Nichols, Environmental Protection Agency
Glenn G. Patterson, National Park Service / U.S.
Geological Survey
Darius Semmens, U.S. Geological Survey
Mark Walbridge, Agricultural Research Service
Richard Webb, U.S. Geological Survey
Ken Williams, U.S. Geological Survey
Mark Williams, University of Colorado

Session Moderators and Facilitators

Brian Caruso, Environmental Protection Agency
Stan Church, U.S. Geological Survey
Heather Golden, Environmental Protection Agency
Rick Hooper, Consortium of Universities for the
Advancement of Hydrologic Science, Inc.
Deborah Martin, U.S. Geological Survey
Cassandra Mullinix, U.S. Geological Survey
Pete Murdoch, U.S. Geological Survey
Jake Peters, U.S. Geological Survey
Darius Semmens, U.S. Geological Survey
Jamie Shanley, U.S. Geological Survey
Michelle Walvoord, U.S. Geological Survey
Richard Webb, U.S. Geological Survey
Ed Weeks, U.S. Geological Survey

Field Trip Leaders

Don Campbell, U.S. Geological Survey
Dave Clow, U.S. Geological Survey
Doug Halm, U.S. Geological Survey
Bob Jarrett, U.S. Geological Survey
Deborah Martin, U.S. Geological Survey
Alisa Mast, U.S. Geological Survey
Glenn G. Patterson, National Park Service
Travis Schmidt, U.S. Geological Survey
Judy Visty, National Park Service
Mark Williams, University of Colorado

Facilitation

Todd Bryan, Keystone Center
Jody Erickson, Keystone Center

Contents

Preface	iii
Acknowledgments.....	vi
Conference Program	3

Conference Papers and Extended Abstracts

Plenary Sessions

Abstracts.....	11
U.S. Forest Service Research and Development Agency Update—From the Forest to the Faucet, by K. Elder and D. Hayes.....	13
American Indian Tribes and the Development of Water Resources, by D. Cordalis.....	14
Contributions of the University Community to Watershed Research, by R.P. Hooper, D.R. Maidment, and D.B. Kirschtel	15
The Finger Lakes Watershed Environmental Network (FLoWEN)—A Web Services-Based Approach to Environmental Monitoring Data Management, by R. Lopez-Torrijos, F. Pieper, and B. Houston.....	16
Manuscripts	17
Managing the Uncertainties on the Colorado River System, by E. Kuhn.....	19
Adaptive Management of Watersheds and Related Resources, by B.K. Williams.....	27
The National Wildlife Refuge System and Resource Management in a Watershed Context, by A. Loranger	35
Selected Achievements, Science Directions, and New Opportunities for the WEBB Small Watershed Research Program, by P.D. Glynn, M.C. Larsen, E.A. Greene, H.L. Buss, D.W. Clow, R.J. Hunt, M.A. Mast, S.F. Murphy, N.E. Peters, S.D. Sebestyen, J.B. Shanley, and J.F. Walker.....	39
Climate Change Adaptation Lessons from the Land of Dry Heat, by G. Garfin, K. Jacobs, and J. Buizer.....	53
An Ecosystem Services Framework for Multidisciplinary Research in the Colorado River Headwaters, by D.J. Semmens, J.S. Briggs, and D.A. Martin	59
Engaging Stakeholders for Adaptive Management Using Structured Decision Analysis, by E.R. Irwin and K.D.M. Kennedy.....	65

Climate, Geology, and Geomorphology

Abstracts.....	69
Considerations in Defining Climate Change Scenarios for Water Resources Planning, by L.D. Brekke	71
Understanding the Effects of Climate Change in the Yukon River Basin through a Synergistic Research Approach, by M. Walvoord, P. Schuster, and R. Striegl.....	72
Impacts of Coalbed Methane Development on Water Quantity and Quality in the Powder River Basin, by G.B. Paige and L.C. Munn.....	74
Paleoflood Research of South Boulder Creek Basin near Boulder, Colorado, by R.D. Jarrett and J.C. Ferris	75
Manuscripts	77

Evaluating Hydrological Response to Forecasted Land-Use Change—Scenario Testing with the Automated Geospatial Watershed Assessment (AGWA) Tool, by W.G. Kepner, D.J. Semmens, M. Hernandez, and D.C. Goodrich.....	79
Environmental Effects of Hydrothermal Alteration and Historical Mining on Water and Sediment Quality in Central Colorado, by S.E. Church, D.L. Fey, T.L. Klein, T.S. Schmidt, R.B. Wanty, E.H. DeWitt, B.W. Rockwell, and C.A. SanJuan	85
U.S. Geological Survey Research in Handcart Gulch, Colorado—An Alpine Watershed with Natural Acid-Rock Drainage, by A.H. Manning, J.S. Caine, P.L. Verplanck, D.J. Bove, and K.G. Kahn	97
Water Quality Impacts from Agricultural Land Use in Karst Drainage Basins of SW Kentucky and SW China, by T.W. Baker and C.G. Groves.....	103
Impacts of Forest Management on Runoff and Erosion, by W.J. Elliot and B.D. Glaza....	117
Modeled Watershed Runoff Associated with Variations in Precipitation Data, with Implications for Contaminant Fluxes—Initial Results, by H.E. Golden, C.D. Knightes, E.J. Cooter, and R.L. Dennis	129
Post-Fire Watershed Response at the Wildland-Urban Interface, Southern California, by P.M. Wohlgemuth, K.R. Hubbert, J.L. Beyers, and M.G. Narog.....	137

Hydrology, Biogeochemistry, and Ecology

Abstracts.....	143
Isotopic Signatures of Precipitation Quantify the Importance of Different Climate Patterns to the Hydrologic Budget—An Example from the Luquillo Mountains, Puerto Rico, by M.A. Scholl and J.B. Shanley	145
Mercury Cycling Research Using the Small Watershed Approach, by J. Shanley and A. Chalmers	146
Manuscripts	147
Soil Evaporative Response to Lehmann Lovegrass <i>Eragrostis lehmanniana</i> Invasion in a Semiarid Watershed, by M.S. Moran, E.P. Hamerlynck, R.L. Scott, W.E. Emmerich, and C.D. Holifield Collins	149
Using a Coupled Groundwater/Surface-Water Model to Predict Climate-Change Impacts to Lakes in the Trout Lake Watershed, Northern Wisconsin, by J.F. Walker, R.J. Hunt, S.L. Markstrom, L.E. Hay, and J. Doherty.....	155
Using Passive Capillary Samplers to Collect Soil-Meltwater Endmembers for Stable Isotope Analysis, by M.D. Frisbee, F.M. Phillips, A.R. Campbell, and J.M.H. Henrickx	163
Using High Frequency Sampling to Detect Effects of Atmospheric Pollutants on Stream Chemistry, by S.D. Sebestyen, J.B. Shanley, and E.W. Boyer.....	171
Flowpath Contributions of Weathering Products to Stream Fluxes at the Panola Mountain Research Watershed, Georgia, by N.E. Peters and B.T. Aulenbach	177
Responses of Benthic Macroinvertebrates to Urbanization in Nine Metropolitan Areas of the Conterminous United States, by T.F. Cuffney, G. McMahon, R. Kashuba, J.T. May, and I.R. Waite	187
Aquatic Ecosystems in Central Colorado Are Influenced by Mineral Forming Processes and Historical Mining, by T.S. Schmidt, S.E. Church, W.H. Clements, K.A. Mitchell, D.L. Fey, R.B. Wanty, P.L. Verplanck, C.A. San Juan, T.L. Klein, E.H. DeWitt, and B.W. Rockwell	195
Timber Harvest and Turbidity in North Coastal California Watersheds, by R.D. Klein.....	207

Facilitating Adaptive Management in the Chesapeake Bay Watershed through the Use of Online Decision Support Tools, by C. Mullinix, S. Phillips, K. Shenk, P. Hearn, and O. Devereux	213
---	-----

Poster Session and Field Trip Orientation

Abstracts.....	219
Reflections on the July 31, 1976, Big Thompson Flood, Colorado Front Range, USA, by R.D. Jarrett and J.E. Costa	221
Climate-Induced Changes in High Elevation Nitrogen Dynamics, by J.S. Baron, T.M. Schmidt, and M.D. Hartman.....	222
Potential Climate Impacts on the Hydrology of High Elevation Catchments, Colorado Front Range, by M.W. Williams, K.H. Hill, N. Caine, J.R. Janke, and T. Kittel.....	223
Manuscripts	225
Monitoring Hydrological Changes Related to Western Juniper Removal—A Paired Watershed Approach, by T.L. Deboodt, M.P. Fisher, J.C. Buckhouse, and J. Swanson	227
A Study on Seed Dispersal by Hydrochory in Floodplain Restoration, by H. Hayashi, Y. Shimatani, and Y. Kawaguchi.....	233
Lessons Learned in Calibrating and Monitoring a Paired Watershed Study in Oregon’s High Desert, by M. Fisher, T. Deboodt, J. Buckhouse, and J. Swanson	237
Hydrologic Instrumentation and Data Collection in Wyoming, by G.B. Paige, S.N. Miller, T.J. Kelleners, and S.T. Gray.....	241
Advanced Spatial and Temporal Rainfall Analyses for Use in Watershed Models, by D. Hultstrand, T. Parzybok, E. Tomlinson, and B. Kappel.....	245
Primary Factors Affecting Water Quality and Quantity in Four Watersheds in Eastern Puerto Rico, by S.F. Murphy and R.F. Stallard	251

Human Impacts and Management

Abstracts.....	257
The Importance of Considering Aquifer Susceptibility and Uncertainty in Developing Water Management and Policy Guidelines, by T. Wellman	259
Water Quality Screening Tools—A Practical Approach, by B. Houston and R. Klosowski	260
Herbicide Transport Trends in Goodwater Creek Experimental Watershed, by R.N. Lerch, E.J. Sadler, K.A. Sudduth, and C. Baffaut	261
A Watershed Condition Assessment of Rocky Mountain National Park Using the FLoWS Tools, by D.M. Theobald and J.B. Norman	262
Manuscripts	263
Long-Term Patterns of Hydrologic Response after Logging in a Coastal Redwood Forest, by E. Keppeler, L. Reid, and T. Lisle	265
Recognizing Change in Hydrologic Functions and Pathways due to Historical Agricultural Use—Implications to Hydrologic Assessments and Modeling, by C.C. Trettin, D.M. Amatya, C. Kaufman, N. Levine, and R.T. Morgan	273
Integrating Terrestrial LiDAR and Stereo Photogrammetry to Map the Tolay Lakebed in Northern San Francisco Bay, by I. Woo, R. Storesund, J.Y. Takekawa, R.J. Gardiner, and S. Ehret.....	279
Does Climate Matter? Evaluating the Effects of Climate Change on Future Ethiopian Hydropower, by P. Block and C. Brown	285

Conversion Factors

[To convert from inch/pound to SI units divide by the conversion factor]

Multiply	By	To obtain
Length		
millimeter (mm)	0.03937	inch (in.)
meter (m)	3.281	foot (ft)
kilometer (km)	0.6214	mile (mi)
Area		
square kilometer (km ²)	247.1	acre
hectare (ha)	2.471	acre
square meter (m ²)	10.76	square foot (ft ²)
square kilometer (km ²)	0.3861	square mile (mi ²)
Volume		
liter (L)	0.2642	gallon (gal)
cubic meter (m ³)	264.2	gallon (gal)
cubic meter (m ³)	35.31	cubic foot (ft ³)
cubic meter (m ³)	0.000811	acre-ft (acre-ft)
cubic meter (m ³)	6.289811	barrel, petroleum
Rate		
cubic meter per second (m ³ /s)	70.07	acre-foot per day (acre-ft/d)
cubic meter per second (m ³ /s)	35.31	cubic foot per second (ft ³ /s or cfs)
cubic meter per day (m ³ /d)	35.31	cubic foot per day (ft ³ /d)
cubic meter per day (m ³ /d)	264.2	gallon per day (gal/d)
meter per second (m/s)	3.281	foot per second (ft/s)
meter per day (m/d)	3.281	foot per day (ft/d)
cubic meter per kilometer (m ³ /km)	56.83	cubic foot per mile (ft ³ /mi)
kilogram per second (kg/s)	2.205	pound per second (lb/s)
Mass		
gram (g)	0.03527	ounce, avoirdupois (oz)
kilogram (kg)	2.205	pound avoirdupois (lb)
Pressure		
kilopascal (kPa)	0.2961	inch of mercury at 60°F (in Hg)
kilopascal (kPa)	0.1450	pound per square inch (lb/ft ²)
Density		
gram per cubic centimeter (g/cm ³)	62.4220	pound per cubic foot (lb/ft ³)

Hydraulic conductivity		
meter per day (m/d)	3.281	foot per day (ft/d)
Loading or yield		
kilogram per hectare (kg/ha)	0.89218	pound per acre(lb/acre)
Power		
Watt per square meter (W/m ²)	2.069	Langley per day
kilowatt-hour (kW-h)	3,410	British Thermal Unit (BTU)
Transmissivity		
meter squared per day (m ² /d)	10.76	foot squared per day (ft ² /d)

Temperature in degrees Celsius (°C) may be converted to degrees Fahrenheit (°F) as follows:

$$^{\circ}\text{F} = (1.8 \times ^{\circ}\text{C}) + 32$$

Temperature in degrees Fahrenheit (°F) may be converted to degrees Celsius (°C) as follows:

$$^{\circ}\text{C} = (^{\circ}\text{F} - 32) / 1.8$$

Altitude, as used in this report, refers to distance above the vertical datum.

Abbreviations Used in This Report

gram	g
liter	L
meter	m
milliequivalent	meq
millimole	mmol
micromole	μmol
mole	mol
molar	M
percent	%
per mille	‰
parts per million	ppm
parts per billion	ppb

Acronyms are defined the first time they are used in each manuscript.

Planning for an Uncertain Future— Monitoring, Integration, and Adaptation

**Proceedings of the Third Interagency Conference on
Research in the Watersheds**

8–11 September 2008, Estes Park, Colorado

Richard M.T. Webb and Darius J. Semmens, editors

Conference Program

Preconference Workshops

Sunday, September 7, 2:00PM–8:00PM

Collaborative Competencies, facilitated by Todd Bryan, Principal with the Keystone Center, Glendale Springs, CO

Monday, September 8, 8:00AM–2:00PM

Adaptive Management, facilitated by Ken Williams, Chief of Cooperative Programs, USGS, Reston, VA

Monday, September 8

5:00 PM Arrival / Check in / Registration

6:00 PM Welcome Speech—Eric Kuhn, General Manager of the Colorado River Conservation District

6:20 PM Barbecue at Trails End

Tuesday, September 9

7:00 AM Breakfast / Registration

8:00 AM Welcome and Orientation

8:20 AM Adaptive Management of Renewable Natural Resources—Ken Williams, Chief of Cooperative Programs, USGS Biological Resources Discipline

8:40 AM Strengthening Connections Between Science and Management: Some Recent Developments in the National Park Service—Jeff Albright, Hydrologist, Natural Resources Program, National Park Service

9:00 AM Kelly Elder, Research Hydrologist, National Forest Service

9:20 AM The National Wildlife Refuge System and Resource Management in a Watershed Context—Andy Loranger, Chief, Division of Natural Resources and Conservation Planning, National Wildlife Refuge System, U.S. Fish and Wildlife Service

9:40 AM Break

10:00 AM American Indian Tribes and the Development of Water Resources—Daniel Cordalis, Former natural resources legislative assistant with the National Congress of American Indians

10:20 AM Water Cycle Changes as the Primary Delivery Mechanism for Climate Change Impacts—Brad Udall, Director, CU-NOAA Western Water Assessment

10:40 AM ARS' Benchmark Watershed Research Network: Past Accomplishments, Present Status, and Future Directions—M.R. Walbridge, National Program Leader, Agricultural Research Service

11:00 AM Watershed Management Research in the US EPA—Chuck Noss, National Program Director, Water Quality Research

11:20 AM Curt Brown, Director, Office of Research and Development, Bureau of Reclamation

11:40 AM Watershed Research: Needs and Opportunities—Ron Huntsinger, National Science Coordinator, Bureau of Land Management

12:00 PM Lunch

1:00 PM Pierre Glynn, Chief of National Research Program, Eastern Region

- 1:20 PM Contributions of the University Community to Watershed Research—R.P. Hooper, D.R. Maidment, and D.B. Kirschtel, Director, Consortium of Universities for the Advancement of Hydrologic Science
- 1:40 PM Gregg Garfin, Director of Science Translation and Outreach, Institute for the Study of Planet Earth, University of Arizona
- 2:00 PM Ground Rules for Regional Forums on Adaptive Management
- 2:20 PM Break

2:40 PM	National (Nat) (Meeker)	Arid West (AW) (Longs Peak)	Interior Temperate and Boreal (ITB) (Lady Wash)	Low Latitudes and Maritime (LLM) (Twin Sisters)
---------	------------------------------------	--	--	--

Panel discussions will identify goals, objectives, stakeholders, current science, uncertainty, and monitoring needs for candidate watersheds. Separate tracks for National (NAT), Arid West (AW), Interior Temperate and Boreal (ITB), and Low Latitudes and Maritime (LLM).

Regional Session 1: Climate, Geology, and Geomorphology

	NAT1 Moderator: Pete Murdoch	AW1 Moderator: Stan Church	ITB1 Moderator: Michelle Walvoord	LLM1 Moderator: Jamie Shanley
3:30 PM	Considerations in Defining Climate Change Scenarios for Water Resources Planning—L.D. Brekke	Long-Term Snow, Climate, and Streamflow Trends at the Reynolds Creek Experimental Watershed, Owyhee Mountains, Idaho, USA—D. Marks, A. Nayak, M. Seyfried, and D. Chandler	Impacts on Water and Ecological Resources in the Yukon River Basin Due to Historical Changes in Climate—Michelle Walvoord and Paul Schuster	Evaluating Hydrological Response to Forecasted Land-Use Change: Scenario Testing with the Automated Geospatial Watershed Assessment Tool—William G. Kepner, Darius J. Semmens, Mariano Hernandez, and David C. Goodrich
3:50 PM	Impacts of Coalbed Methane Development on Water Quantity and Quality in the Powder River Basin—G.B. Paige and L.C. Munn	Environmental Effects of Hydrothermal Alteration on Water and Sediment Quality in Central Colorado—S.E. Church, D.L. Fey, T.S. Schmidt, R.B. Wanty, B.W. Rockwell, C.A. San Juan, P.L. Verplanck, and M. Adams	U.S. Geological Survey Research in Handcart Gulch, Colorado: An Alpine Watershed with Natural Acid-Rock Drainage—A.H. Manning, J.S. Caine, P.L. Verplanck, and D.J. Bove	Water Quality Impacts from Agricultural Land-Use in Karst Drainage Basins of SW Kentucky and SW China—T.W. Baker and C.G. Groves
4:10 PM	Impacts of Forest Management on Runoff and Erosion—W.J. Elliot and B.D. Glaza	Paleoflood Research of South Boulder Creek Basin near Boulder, Colorado—Robert D. Jarrett and Justin C. Ferris	Modeled Watershed Runoff Associated with Variations in Precipitation Data, with Implications for Contaminant Fluxes—Heather E. Golden, Christopher D. Knightes, Ellen J. Cooter, and Robin L. Dennis	Post-Fire Watershed Response at the Wildland/Urban Interface, Southern California—Peter M. Wholgemuth

4:30 PM Break

Regional Session 2: Hydrology, Biogeochemistry, and Ecology

	NAT2 Moderator: Rick Webb	AW2 Moderator: Ed Weeks	ITB2 Moderator: Darius Semmens	LLM2 Moderator: Jake Peters
4:40 PM	The USGS Hydrologic Benchmark Network: Capabilities and Opportunities for Collaborative Monitoring and Research—D.W. Clow, M.A. Mast, M. McHale, and M. Nilles	Using Diurnal Surface Temperature Variation to Monitor Evaporation from Soils in a Semiarid Rangeland—M. Susan Moran, Russell L. Scott, Timothy O. Keefer, William E. Emmerich, and Erik P. Hamerlynck	Using a Coupled Ground-Water/Surface-Water Model to Predict Climate-Change Impacts to Lakes in the Trout Lake Watershed, Northern Wisconsin—John F. Walker, Randall J. Hunt, Steven L. Markstrom, Lauren E. Hay, and John Doherty	Isotopic Signatures of Precipitation Quantify the Importance of Different Climate Patterns to the Hydrologic Budget: An Example from the Luquillo Mountains, Puerto Rico—M.A. Scholl and J.P. Shanley
5:00 PM	Mercury Cycling Research Using the Small Watershed—Jamie Shanley and Ann Chalmers	Using Passive Capillary Samplers to Collect Snowmelt Recharge and Soil-Meltwater Endmembers for Stable Isotope Analysis—Marty D. Frisbee, Fred M. Phillips, Andrew R. Campbell, and Jan M.H. Hendrickx	The Role for High Frequency Sampling in Documenting the Effects of Atmospheric Pollutants on Stream Chemistry—Stephen D. Sebestyen, Jamie Shanley, and Elizabeth Boyer	Effects of 21 Years of Climate Variation and Regional Urbanization on Precipitation and Streamwater Chemistry of a Relatively Undisturbed Forested Watershed near Atlanta, Georgia—Norman E. Peters and Brent T. Aulenbach
5:20 PM	Responses of Benthic Macroinvertebrates to Environmental Changes Associated with Urbanization in Nine Metropolitan Areas of the Conterminous United States—T.F. Cuffney, G. McMahon, J.T. May, and I.A. Waite	The Effect of Mining on Aquatic Communities in Central Colorado—T.S. Schmidt, S.E. Church, W.H. Clements, K. Mitchell, D.L. Fey, R.B. Wanty, P.L. Verplanck, C.A. San Juan, and M. Adams	Timber Harvest, Turbidity, and Implications for Anadromous Salmonids in North Coastal California Streams—R.D. Klein	Facilitating Adaptive Management in the Chesapeake Bay Watershed through the Use of On-Line Decision Support Tools—C. Mullinix, S. Phillips, and P. Hearn

6:00 PM Dinner in the Ptarmigan Dining Room

6:30 PM

Poster Session in the Lodge

Forecasting Colorado Streamflow under Natural Climate Variability—Jason Gurdak	Monitoring Hydrological Changes Related to Western Juniper Removal: A Paired Watershed Approach—Tim Deboodt, Mike Fisher, John Buckhouse, and John Swanson	Basin Attributes Contributing to Chemical Composition of Streamwater in Headwater Catchments of the Colorado Rockies—C. Rhoades, J. Norman III, E. Kelly, and K. Elder	A Study on Seed Dispersal by Hydrochory in Floodplain Restoration—H. Hayashi, Y. Shimatani, and Y. Kawaguchi
Lessons Learned in Calibrating and Monitoring a Paired Watershed Study in Oregon’s High Desert—Mike Fisher, Tim Deboodt, John Buckhouse, and John Swanson	Hydrologic Instrumentation and Data Collection in Wyoming—G.B. Paige, S.N. Miller, T.J. Kelleners, and S.T. Gray	High Spatial and Temporal Rainfall Analyses for Use in Watershed Models—Douglas Hultstrand, Tye Parzybok, Ed Tomlinson, and Bill Kappel	Watershed Management in Nepal—Tak Bahadur Tamang
Reflections on the July 31, 1976, Big Thompson Flood, Colorado Front Range, USA—Robert D. Jarret and John E. Costa	A Synergistic Approach to Hydrologic Research and Education in the Yukon River Basin—Paul Schuster and Michelle Walvoord	Effects of Mountain Pine Beetle Induced Tree Mortality on Carbon and Nitrogen Fluxes in Northern Colorado—Dave Clow and others	Climate-Induced Changes in High Elevation Nitrogen Dynamics—Jill S. Baron, Travis M. Schmidt, and Melannie D. Hartman
Potential Climate Impacts on the Hydrology of High Elevation Catchments, Colorado Front Range—M.W. Williams, K.H. Hill, N. Caine, J.R. Janke, and T. Kittel			

Wednesday, September 10

(Breakfast available at 6:30 AM)

Field Trips (Box Lunch)

7:00 AM Andrew's Meadow*—Alisa Mast

Icy Brook*—Dave Clow

7:45 AM Loch Vale*—Don Campbell

Long Term Ecological Research on Niwot Ridge—Mark Williams

8:30 AM Aquatic Ecology of the Big Thompson River and Cub Lake—Glenn Patterson and Travis Schmidt

Floods, Paleofloods, and Wildfire Hydrology, Big Thompson Canyon—Deborah Martin and Bob Jarrett

4:00 PM Return to Lodge

*All Loch Vale trips start at the Glacier Gorge trailhead, which is at 9,180 ft elevation. The Loch: 7 miles (RT), 1,000 ft elevation gain, all on trail. Andrew's Meadow: 8.5 miles (RT), 1,320 ft elevation gain, all on trail. Icy Brook/Glass Lake: 10 miles (RT), 1,670 ft elevation gain, mostly on trail, some class 2 scrambling (requires use of hands) above treeline.

Bring: Layered clothing as appropriate, jacket, rain coat or poncho, box lunch, back pack, water bottle, sunscreen, lip balm, good sneakers or hiking shoes or boots, camera.

Regional Session 3: Human Impacts and Management

	NAT3 Moderator: Brian Caruso	AW3 Moderator: Deb Martin (Fireside)	ITB3 Moderator: Heather Golden	LLM3 Moderator: Rick Webb
4:40 PM	The Importance of Considering Aquifer Susceptibility and Uncertainty in Developing Water Management and Policy Guidelines—Tristan Wellman	Evaluating Regional Patterns in Nitrate Sources to Watersheds in National Parks of the Rocky Mountains Using Nitrate Isotopes—Leora Nanus, Mark W. Williams, Donald H. Campbell, Carol Kendall, and Emily M. Elliot	USDA–ARS and Filtrexx International Research on Storm Water Pollutant Removal Effectiveness of Compost Filter Socks—Britt Faucette	Long-Term Patterns of Hydrologic Response after Logging in a Coastal Redwood Forest—Elizabeth Keppeler, Leslie Reid, and Tom Lisle
5:00 PM	Water Quality Screening Tools: A Practical Approach—Benjamin Houston and Rob Klosowski	Design and Implementation of a Water-Quality Monitoring Program in Support of Establishing User Capacities in Yosemite National Park—R.S. Peavler, D.W. Clow, A.K. Panorska, and J.M. Thomas	Herbicide Transport Trends in Goodwater Creek Experimental Watershed—R.N. Lerch, E.J. Sadler, K.A. Sudduth, and C. Baffaut	Assessing Changes in Hydrologic Function Using Historical Records and Contemporary Measurements—C.C. Trettin, D.A. Amatya, C. Kaufman, R. Morgan, and N. Levine
5:20 PM	Break	A Watershed Condition Assessment of Rocky Mountain National Park Using the FLoWS Tools—David M. Theobald and John B. Norman	Integrating Terrestrial LiDAR and Real Time Kinematic GPS Surveys to Map the Upper Tolay Creek Watershed of San Francisco Bay—Isa Woo, John Takekawa, Rachel Gardiner, and Rune Storesound	Does Climate Matter? Evaluating the Effects of Climate Change on Future Ethiopian Hydropower— Paul Block
6:00 PM	Awards Banquet in Longs Peak			

Conference Papers and Extended Abstracts

Plenary Sessions—Abstracts

U.S. Forest Service Research and Development Agency Update: From the Forest to the Faucet

Kelly Elder, Deborah Hayes

Abstract

The U.S. Forest Service Research and Development (FS R&D) Mission is to develop and deliver knowledge and innovative technology to improve the health and use of forests and Rangelands. Watershed research is a pivotal part of that mission. To accomplish this mission, the Forest Service currently has more than 500 scientists working in 77 field laboratories. Research is conducted on 80 Experimental Forests and Ranges (EFRs) and 370 Research Natural Areas. Research is also conducted on non-FS sites through over 1,000 cooperative research agreements with partners.

In 2005, FS R&D remodeled its structure into Strategic Program Areas (SPAs). The purpose was to integrate the major research programs by developing a matrix organization which increased accountability and provided tracking of significant accomplishments. This new model will provide an organizational structure responsive to current and anticipated demands for research and will cover a broad range of current and future issues. The interdisciplinary areas created as SPAs are: (1) Resource Management and Use, (2) Wildland Fire, (3) Resource Data and Analysis, (4) Invasive Species, (5) Outdoor Recreation, (6) Water, Air, and Soil, and (7) Wildlife and Fish.

The Water, Air, and Soil Strategic Program Area includes four portfolios: emerging threats to ecosystem sustainability; understanding ecosystem processes; climate variability affects on watersheds; and the delivery and application of research outcomes. The SPA will build on the established core strengths of a high integration among water, air, and soil research and will assist with integration of the biophysical and social sciences by emphasizing spatial patterns and ecological processes, linking freshwater and marine systems, evaluating the effects of climate variability, and using the power of a network of experimental lands to address important research questions. Another new aspect of research being integrated into the SPA is that of social sciences, including the assessment of the public's value systems and research-management policy linkages.

Within the SPA, FS R&D created an EFR Synthesis Network in 2007. The Network includes 18 established sites within the continental United States and Hawaii, Alaska, and Puerto Rico. The purpose of the Synthesis Network is to assemble long-term data sets and evaluate the state of knowledge across a number of different gradients to address current and future driving forces in the watershed. The Network participants are currently collaborating on the assembly of intersite long-term data sets for a number of areas, including water availability and chemistry, biofuels assessment, and vegetation dynamics with a changing climate. A detailed site description of each network participant is being developed to assist other researchers in utilizing long-term data from the Network sites.

Hayes is the National Program Leader for Watershed and Soil Research in Washington, DC. Elder is a research hydrologist at the U.S. Forest Service, Rocky Mountain Research Station, Fort Collins, CO, and the Scientist in Charge (SIC) at the Fraser Experimental Forest, Fraser, CO. Email: deborahhayes@fs.fed.us; kelder@fs.fed.us.

American Indian Tribes and the Development of Water Resources

Daniel Cordalis

Abstract

Water rights are possibly the most important right many Indian tribes have yet to exercise. When reservations were established, water rights ("Winters Rights") were also reserved by Indian tribes. These water rights were intended to ensure that tribes would have a sufficient supply of water to meet the agricultural, domestic, industrial, and municipal water needs of the reservations. Ironically, despite its legal obligation to protect these rights as trustee, the United States Government developed water policy and related infrastructure benefiting non-Indian communities without consideration of tribal interests. As a result, many tribal communities now suffer from inadequate, often compromised water supplies that hamper reservation economic and community development and prohibit effective fire protection. Furthermore, water resources and aquatic ecosystems crucial to tribal communities for cultural survival are often impaired by over-appropriation by non-Indian interests.

Water concerns facing Indian tribes look very similar to the issues facing non-Indians, except tribes have fewer monetary and political resources to approach their concerns, while typically starting a few steps behind. However, there is opportunity in where we stand today. Despite constant uncertainty as to whether the Federal Government will uphold its trust duties, Indian tribes are moving forward and trying to exercise their water rights in the most beneficial capacity possible. Most often this means attempting to work to secure water resources for their communities, many of which still have no running water. In the 21st century this requires more than a pick and a shovel; it requires coordination, cooperation, and collaboration. Tribes are bringing together water users to forge workable agreements that can sustain each other's needs and also promote ecosystem health. These water settlements allow Indian tribes to fulfill their water rights and simultaneously build modern infrastructure using local values and knowledge. Significant obstacles exist across tribal communities, but access to a clean reliable water supply should not be one of them.

Cordalis, a former American Indian policy advocate and member of the Navajo Nation, is currently studying environmental law at the University of Colorado. Email: dcordalis@gmail.com.

Contributions of the University Community to Watershed Research

R.P. Hooper, D.R. Maidment, D.B. Kirschtel

Abstract

The Consortium of Universities for the Advancement of Hydrologic Science, Inc. (CUAHSI), founded in 2001, has been developing infrastructure for use by the hydrologic science community with the support of the National Science Foundation. Central themes have been the development of informatics, instrumentation, multidisciplinary synthesis, and observatory facilities to enable integrated research in the hydrologic cycle and to support research at larger scales and for longer durations than typical academic projects in the past. Federal partners, such as the U.S. Geological Survey, the U.S. Environmental Protection Agency, and the National Climate Data Center, have been supportive of these efforts. Pilot projects have been undertaken in all of these areas with results that are of interest to the broader watershed research and management community. The most advanced of these projects, CUAHSI Hydrologic Information Systems, is described in this paper.

The CUAHSI Hydrologic Information System (HIS) is designed to improve access to the Nation's water data. An important part of this information are time series of observations made at point locations, such as precipitation and streamflow gages, soil water and climate stations, groundwater wells, and water quality sampling sites in surface and groundwater. These data can be stored in the CUAHSI Observations Data Model, communicated through the Internet using the WaterML language, and cataloged in a national water metadatabase. Individual researchers and research organizations can use these facilities to publish their water data as a CUAHSI Water Data Service.

These Water Data Services will permit watershed researchers to publish their data online and to be discovered by the broader research and management community far more easily than was possible in the past. Integrating data from multiple sources promises to provide a more complete description of our environment and to permit better management decisions.

Hooper and Kirschtel are scientists with CUAHSI, 2000 Florida Avenue, NW, Washington, DC 20009. Maidment is a professor at University of Texas, Center for Research in Water Resources, Austin, TX 78712. Email: rhooper@cuahsi.org; dkirschtel@cuahsi.org; maidment@mail.utexas.edu.

The Finger Lakes Watershed Environmental Network (FLoWEN): A Web Services–Based Approach to Environmental Monitoring Data Management

Ricardo Lopez-Torrijos, Fred Pieper, Benjamin Houston

Abstract

Within the Adaptive Management water resources program circular paradigm of “Assess > Design > Implement > Monitor > Evaluate > Adjust > Assess,” the local stakeholders are limited with monotonous regularity to their own resources in trying to confront water resource degradation and threats. During assessment and design, the watershed management tools available to the land manager are more frequently indirect (e.g. a permitting process) than direct; there is a critical lack of scientific analysis and interpretation to help the implementation group and management understand the problem assessment and response design. At implementation time the local manager’s monitoring needs are the same as for the State or Federal manager: fluid communication across participant groups and technical/scientific boundaries is paramount for success. In particular, access to data in an appropriate presentation and time frame is necessary. In the Finger Lakes Region of New York State, efforts have been underway to develop standard protocols for managing both remotely sensed monitoring data and historic environmental monitoring data in such a way that facilitates exploration, discovery, and collaboration. Based on the CUAHSI (Consortium of Universities for the Advancement of Hydrologic Science, Inc.) Hydrologic Information System architecture, a regional system was built to consume remotely sensed monitoring data from regionally managed buoys, stream gages, and precipitation stations and integrate that data with State and Federal programs and existing CUAHSI-based services. The system provides mechanisms to consume data directly from locally managed sensors in the field as well as local historical environmental monitoring data, and to translate that information into a common data model for warehousing and distribution. Data are published through a standardized web services architecture. A prototype web-based viewer for data exploration and discovery offers potential data users the opportunity to evaluate specific data elements both spatially and graphically (time series) from a range of sources and warehouses and offers options for either direct data extraction or web service connectivity. By standardizing the architecture it becomes possible to decentralize data management while leveraging web services to facilitate collaboration and data sharing. In conclusion, communication and (modern) data sharing among willing stakeholders is the lubricant that makes possible (an adaptive) response to many water resources problems at the local watershed scale.

Lopez-Torrijos and Houston are environmental information management professionals with the Institute for the Application of Geospatial Technology in Auburn, NY. Email: rxlopez@gw.dec.state.ny.us; fpieper@iagt.org; bhouston@GroundPointLLC.com.

Plenary Sessions—Manuscripts

Managing the Uncertainties on the Colorado River System

Welcome Address

Eric Kuhn

Introduction

Ever since pioneers first diverted water in 1854 from the Blacks Fork of the Green River for irrigation purposes, Colorado River waters were considered available for appropriation and development for beneficial use. Until very recently, the basic assumption has been that if we needed additional water supplies, the water was there. To use it, all we needed to do was to build another dam, diversion structure, pumping plant and canal, or pipeline system. New water rights were perfected through beneficial use.

Today, the focus of our basic approach to the Colorado River has changed from one of development to one of reallocation and risk management. Although a number of projects are still under consideration or being actively permitted in the Upper Colorado River Basin, there is a growing consensus that within the Colorado River system as a whole the existing demand for water now exceeds the available supply.

The projects in the Upper Basin being planned today may be developing the unused apportionment of individual Upper Basin states, but from the system-wide perspective, these projects are reallocating existing supplies. The Upper Basin's "unused" water is currently in use in the Lower Basin.

To properly manage a system as complex as the Colorado River Basin, the numerous Federal, State, local, and private entities charged with managing or using the resources of the Colorado River need a fundamental understanding of the basic uncertainties they face.

The development era of the Colorado River has given us a sound foundation of well-run and efficient governmental agencies, water utilities, and irrigation districts. These water entities have developed advanced management and technological skills and highly trained personnel. These same water entities, by necessity, are now faced with the need to develop new planning and management tools to take on a different set of challenges, but with the same basic objective of delivering reliable and high-quality water to their customers at a reasonable price. These new tools are needed as we transition from the era of development to the new era of risk management.

Within the Colorado River Basin, there are three basic sources of uncertainty: hydrology, future demands, and unresolved legal disputes. To address these uncertainties will require the adoption of three broad management strategies: identifying and avoiding unacceptable outcomes, maintaining effective working relationships among stakeholders, and increasing focus and reliance on the use of science in decisionmaking.

The Basic Assumption Concerning the Law of the River

My list of three management strategies does not include any major changes or revisions to what is referred to as "the law of the river." The term "law of the river" refers to the whole body of international treaties, interstate compacts, Supreme Court decisions and decrees, Federal and State laws, and adjudicated water rights that are used to allocate,

Kuhn is General Manager, Colorado River Water Conservation District, Glenwood Springs, CO.

manage, and distribute the waters of the Colorado River system to its many users.

My view is that while there may be a few “tweaks” here and there, it is highly unlikely that there will be major changes to the law of the river for a long time. My fundamental assumption is that the basic tenets of the law of the river will continue to set the boundaries or bookends that will constrain all future management strategies, traditional or new in scope.

Specifically, the obligation of the United States under the 1944 treaty to deliver to the Republic of Mexico 1.5 million acre-feet (maf) per yr in most years will continue unchanged. The basic apportionments made in Articles III a. and III b. of the 1922 Colorado River Compact to the Upper and Lower Basins will not be changed. The obligations of the states of the Upper Division at Lee Ferry under Articles III c. and III d. of the 1922 Colorado River Compact will remain unchanged. The individual apportionments made to the five states with lands in the Upper Basin will continue to be as defined by Article III of the 1948 Upper Colorado River Basin Compact. The 1964 United States Supreme Court decree in *Arizona v. California* will continue to control the deliveries of water on the mainstem of the Colorado River in and below Lake Mead. The 1964 decree along with the 1928 Boulder Canyon Project Act, the 1956 Colorado River Storage Project Act, and the 1968 Colorado River Basin Act will remain largely unchanged and continue to give the United States, through the Secretary of the Interior, very broad powers.

Finally, the myriad of Federal environmental laws such as National Environmental Policy Act (NEPA), the Endangered Species Act (ESA) and the Clean Water Act, will continue to constrain, guide, and influence the many Federal agency decisions and actions required for the management of the river.

It is not that I do not believe that targeted changes to individual elements of the law of the river will not be proposed or actively pursued by individual stakeholders or that future Supreme Court decisions will not further interpret the law of the river. These events could happen. I suggest that there will be no major or fundamental changes to the law of the river because it is simply too difficult in today’s political and legal environment to make changes. Changes to interstate compacts require approval or ratification

by each participant State legislature and Congress. Changes to Federal laws require either a crisis trigger or super majorities in both houses of Congress. Within the Basin States, water rights which define, prioritize, and quantify the amount of water that can be applied to beneficial use are property rights and, except for abandonment for non-use, cannot be easily changed, undone, or ignored.

I believe that the changes in management strategies adopted by cooperative efforts will be allowed and implemented through the existing flexibility and perhaps creative reinterpretation of the existing law of the river.

The Basic Uncertainties

Hydrology

When the 1922 Colorado River Compact was negotiated, the collective wisdom was that the Colorado River system had a total yield of well over 20 maf per yr as measured at Yuma, AZ. In fact, the negotiators believed they were only committing a portion of the available system water. Article III f. provided for a future apportionment of the remaining waters.

Of course history has shown that there would be no future apportionment and, in many if not most years, nature has not even provided enough Colorado River water to cover the original 17.5 maf of water committed for consumptive uses to the Upper and Lower Basins under the 1922 Compact and to Mexico under the 1944 Treaty.

Using the metric of natural flow at Lee Ferry, the general rule has been that the longer the period of record examined, the lower the estimated mean flow. The 1922 Compact negotiators had about 20 yrs of gage records. In 1922 the estimated flow of the Colorado River at Lee Ferry was between 17 and 18 maf per yr. At the time the Upper Colorado River Basin Compact was negotiated in 1948, we had over 40 years of gage data and the estimated mean natural flow at Lee Ferry had dropped to 15.7 maf per yr. Today, the Bureau of Reclamation’s natural flow estimate, based on the 100- yr period of 1905–2004, is about 15.0 maf per yr.

A number of well known studies using the analysis of tree ring data have been published and have expanded the record back 500 yrs or more. These paleohydrology studies suggest a mean flow at Lee Ferry in the range of 13.5–14.8 maf per yr. These reconstructions also suggest that drought periods have occurred that are far more severe and longer lasting than what we have experienced in the post-1905 gage record.

The prospect of climate change–induced flow changes adds additional uncertainty. While there is a wide range of results in the different published studies, all suggest a future Colorado River with less streamflow. In 2007, a report by the National Research Council of the National Academies (2007, p. 3) concluded that “*the preponderance of scientific evidence suggests that warmer future temperatures will reduce future Colorado River stream-flow and water supplies*”. In late 2008, the Colorado Water Conservation Board (Colorado Water Conservation Board, 2008) issued a synthesis report on climate change specifically targeted for water managers. This report warns that “*climate change will affect Colorado’s use and distribution of water. Water managers and planners currently face specific challenges that may be further exacerbated by projected climate changes*”. The study concludes that “*all recent hydrologic projections show a decline in runoff for most of Colorado’s rivers*”. Perhaps Greg Garfin of CLIMAS put it best: “*the certainty of the future temperature increase trumps the uncertainty in future precipitation levels*” (Garfin and Lenant, 2007).

My conclusion is that given the current demands on Colorado River water resources, even a small change in the mean natural flow at Lee Ferry will cause serious problems. Among the most optimistic of the climate impact studies published is the 2006 paper by Christiansen and Lettenmeyer. This study suggested modest reductions in the mean flow at Lee Ferry in the range of 6–10 percent. Most recently, a project by the Western Water Assessment to narrow the results of the various studies suggests the floor for the estimated flow reduction is about 10 percent (Brad Udall, personal commun., September 2009).

Are there credible studies that model the current operation of the Colorado River with a sustained 10 percent reduction on natural flow at Lee Ferry? I believe the answer is yes. Reclamation’s recent

environmental impact statement on the Lower Basin shortage criteria included an alternative hydrology appendix (U.S. Bureau of Reclamation, 2007). The paleohydrology analysis used estimated flows at Lee Ferry (Woodhouse et al., 2006). The paleohydrology-based trace for the period of 1620–1674 is illustrative of my conclusion. This period has an estimated mean flow at Lee Ferry of approximately 13.5 maf per year. The model output shows a number of unacceptable and shocking results. For example, the Central Arizona Project (CAP) would experience 47 straight years of shortages, including a number of individual years when the project would divert no water at all. Lake Mead would drop below and stay below the minimum level for the Las Vegas Valley Water District to pump water to its customers (1000' msl) for a period of close to 20 yrs. California, which has the most senior of the prior perfected rights in the Lower Basin, would experience occasional large shortages.

In the Upper Basin, Lake Powell would operate below the minimum storage level necessary to produce hydroelectric power over 60 percent of the 50-yr period, and there would be two periods, one of 5 yrs and one of 12 yrs, when Lake Powell would be empty and the Upper Basin states would be unable to meet their obligations to the Lower Basin under the 1922 Colorado River Compact.

The lesson is that without major changes in how we currently manage the Colorado River, even a modest decrease in system streamflows on the order of 10 percent could cause significant unacceptable impacts throughout the Basin.

Unresolved legal disputes

It is not hard to understand that with the intense competition for the waters of the Colorado River system and the complex and often conflicting compacts, treaties, and Federal and State statutes that make up “the law of the river,” there are a number of unresolved legal disputes. For the most part, these disputes have been well known for many decades, but until recently there was little incentive to resolve many of them.

However, since the completion and full utilization of the CAP in the mid-1990s, there has been major

effort to reach consensus solutions for a number of previously unresolved matters. The Secretary of the Interior issued interim surplus criteria in 2000 and interim shortage criteria in 2007 for the operation of Lake Mead. The surplus criteria effort included the resolution of major issues in California, including an agreement that quantifies the individual rights of California's senior irrigation users. This agreement is referred to as the QSA, or the Quantification Settlement Agreement. The QSA was a necessary prerequisite to the water transfer agreement between San Diego and the Imperial Irrigation District (IID).

The shortage criteria brought with it a new conjunctive management strategy for the operation of Lake Mead and Lake Powell and the implementation much needed efficiency and conservation projects.

Despite the clear progress, important unresolved legal disputes remain to be addressed. Two sets of related problems are perhaps the most salient. The first set of unresolved issues involves the Republic of Mexico. The second set involves the final quantification and future use of the remaining unadjudicated Indian water rights within the Basin.

There are a number of unresolved issues with respect to Mexico; two of them are especially important to the Upper Basin, and perhaps they could be considered as the opposite sides of the same coin. Under the 1944 Treaty with Mexico, the United States can reduce its deliveries to Mexico: *"in the event of extraordinary drought or serious accident to the irrigation system in the United States making it difficult for the United States to deliver the guaranteed quantity of 1,500,000 acre feet a year, the water allotted to Mexico... will be reduced in the same proportion as consumptive uses in the United States are reduced."*

The obvious question is when are we in an "extraordinary" drought as opposed to an "ordinary" drought? If climate change reduces flows in the Colorado River system, is this a drought or just nature reducing the baseline? Under all reasonable climate change scenarios, there will still be considerable natural variability within the Colorado River Basin.

Currently, a task group of Federal and State water officials is working with counterparts from Mexico

to begin a dialogue on Colorado River water issues. This process is promising, but it will take time and the initial efforts will likely avoid the most difficult issues.

The second Mexico issue is internal to the United States and potentially very divisive. Article III c. of the 1922 Compact states:

(c) *"If, as a matter of international comity, the United States of America shall hereafter recognize in the United States of Mexico any right to the use of any waters of the Colorado River System, such waters shall be supplied first from the waters which are surplus over and above the aggregate of the quantities specified in paragraphs (a) and (b); and if such surplus shall prove insufficient for this purpose, then the burden of such deficiency shall be equally borne by the Upper Basin and the Lower Basin, and whenever necessary the States of the Upper Division shall deliver at Lee Ferry water to supply one-half the deficiency so recognized in addition to that provided in paragraph (d)."*

Among the unanswered questions are: (1) when is there a surplus; (2) when there is a surplus, how is it quantified; (3) where in the Basin is the surplus water located; and (4) does the Upper Basin need to cover transit losses from Lee Ferry to the Mexican border. The stakes are high for both Basins. Is the Upper Basin 10-year obligation at Lee Ferry 75 maf, 82.5 maf, something more, or something in between?

Note that the obligation of the United States to Mexico is an annual obligation, not a ten-year moving average. If the Upper Basin's obligation to Mexico was set at 750,000 af every year, then the total 10-yr obligation would be 82.5 maf.

In Colorado, the answer to the Upper Basin's long-term obligation to Mexico could mean the difference between having enough water or not having enough water to support a large new trans-mountain diversion or perhaps meeting the needs of a large future oil shale industry. If there is no water for additional Colorado River water diversion to the Front Range, the only other practical choice may be agricultural conversions in the Platte and Arkansas Basins. Not having enough water for oil shale could

have similar repercussions for West Slope agriculture.

In the Lower Basin, the question is the effect on Lower Basin tributaries, primarily the Gila River. In all but very rare wet years, the Gila River system is fully used and has been for decades. The Gila River has already been the primary driver for several Supreme Court cases. It was the primary reason Arizona refused to ratify the 1922 Compact until 1944. And as a practical matter, because of high transit losses through the desert from Phoenix to Yuma, the Gila River cannot efficiently make deliveries to Mexico.

The real question is when and how will the Mexican Treaty delivery obligation issues be resolved. Will the issues be resolved through negotiations or litigation, or perhaps through the negotiated settlement of litigation? Unlike the 1928 Boulder Canyon Act, the 1922 Compact does not give the Federal Government any special status to threaten the States with a Secretarial decision.

Up until now, neither Basin has had a real incentive to press for a resolution of the Mexican Treaty issues, but those days may be ending. The States actually came very close to a showdown in 2005. The current dialogue on Mexican issues could force certain issues to the table, and the effects of climate change may accelerate sustained shortages that cannot be addressed without a resolution of Article III c. of the 1922 Compact.

Compared with other major western rivers, the groups governing the Colorado River Basin have made progress in quantifying the reserved rights of the many Indian tribes with lands in the Basin. However, several challenges remain unresolved. The Navajo Nation covers lands in New Mexico, Arizona, and Utah. The Navajo are in a unique position. The tribe has Upper and Lower Basin water interests in New Mexico and Arizona and Upper Basin water interests in Utah. The State of New Mexico and the Navajo Nation have reached a settlement covering the Nation's claims to the San Juan River. This settlement must still be approved by Congress. There are no guarantees Congress will approve the package, which includes Federal financing commitment.

The proposed settlement includes the construction of a water supply pipeline that will pump water from the San Juan River to the Navajo Nation and to the city of Gallup. Gallup is located on a tributary to the Little Colorado River, a Lower Basin tributary. The pipeline would also provide much needed domestic water to tribal users in Arizona. This project raises a number of messy Compact issues, including the concept of crediting the Upper Basin deliveries for water delivered to Arizona via the pipeline as being delivered at Lee Ferry. In the fall of 2008, the Basin States reached a compromise that allowed the legislation to proceed, but reserves for future battle a number of tough issues.

Within Arizona, is there even enough water to satisfy the minimal Navajo claims? Under the 1948 Compact, Arizona was apportioned 50,000 af of Upper Basin water annually. A major portion of this water is already in use to supply a large coal-fired power plant outside of Page. What happens if the Navajo claims to Upper Basin water, which pre-date both the 1922 and 1948 Compacts, cause Arizona's demands to exceed 50,000 af per year? As a sovereign, can the Navajo Nation use its water anywhere within its boundaries? Can it deliver water diverted on the San Juan in Utah to tribal lands in Arizona? For example, as a sovereign, Utah takes the position that it can use its Upper Basin water in the Virgin River, a Lower Basin tributary. It is seeking Federal permits for the construction of a pipeline from Lake Powell to St. George.

Demand uncertainties

The third set of uncertainties involves the demands for the waters of the Colorado River. This problem is not as simple as it may appear. Planning for and meeting the future water demands in the Basin is much more complicated than the traditional demographic-based approaches. Future water demands will be affected by both events in adjacent basins and by futures that will be dramatically different than what we can imagine. To meet the needs of Southern California's 20 million people on the coastal plain (Santa Barbara to San Diego), the Colorado River is one of only four major sources of water. The four sources are the Colorado River Aqueduct, the California State Water Project, the Owens River Aqueduct, and local in-basin sources.

There are significant challenges and uncertainties with each of these supplies. The largest single supply is the State Water Project. This project diverts water from the Sacramento River system in the Bay-Delta. From the Delta it is delivered hundreds of miles south to Southern California. The project is facing enormous challenges: sea water intrusion, ESA limitations, environmental restoration, and a lack of system storage. Recent court decisions have limited the water yield available to the project. Without a comprehensive solution to the Bay-Delta issue, there could be shortages in average years. If the 2008/2009 winter is dry in the Sierras, Metropolitan Water District (MWD) customers could be facing water rationing.

The bottom line is that the State Water Project water supplies to Southern California are likely to be smaller in the future. This puts more pressure on MWD to firm up its Colorado River supplies. Within California, it has the most junior Colorado River rights. To firm up its Colorado River supply, it needs to transfer existing senior agricultural uses. It has already done so, with some success. When California is limited to its normal year apportionment of 4.4 maf per yr, MWD's senior rights provide about 550,000 af per yr. Its aqueduct has a capacity to pump 1.2 maf per yr. Through agricultural transfer fallowing and conservation programs with Palo Verde and the IID, in 2007 and 2008 the IID pumped over 700,000 af per yr. Will the politics in the Imperial Irrigation District allow more transfers, enough to fill the remaining capacity of the Colorado River aqueduct? If not, where will MWD turn? Will its efforts ultimately lead to the Upper Basin?

Likewise, central Arizona has three major sources of supply: the Central Arizona Project (CAP), the Gila/Salt River System, and groundwater. Groundwater is already over-tapped and aggressively managed. The CAP is the most junior project in the Lower Basin and potentially subject to prolonged periods of shortage. The Gila River system, including its major tributaries the Salt and Verde Rivers, is a vital supply that has historically provided approximately 1.5–2.0 maf per yr of water for irrigation and municipal purposes. The Salt/Verde system drains the Mogollon Rim and the White Mountains. Compared with the Colorado Rockies, this watershed is at a low elevation, 7,000–10,000 ft. The current climate science suggests that

the southwestern United States and lower elevation watersheds will be the most susceptible to climate change.

Thus, Arizona faces a future of its local supplies reduced by climate change and its CAP subject to prolonged shortage; its groundwater basins are already over-tapped. What are Arizona's options? Are strategies such as the construction of large desalination facilities in Mexico on the shores of the Gulf of Baja California politically or economically feasible? Strategies such as aggressive re-use, the desalinization of local brackish groundwater, and the lease of senior Indian agricultural rights from the Arizona side of the mainstem appear more likely. At the 2008 Colorado River Water Users Convention in Las Vegas, a water planner from the CAP suggested that in the future Arizona might build a pipeline from the Mississippi River (or maybe Lake Michigan) to the Colorado Front Range so that Arizona could exchange the Mississippi River water for the approximate 600,000 af of Colorado River water used on the Front Range.

In the Upper Basin, the major demand uncertainty is energy, specifically oil shale development. With the recent cost of oil and geopolitical concerns, there has been a surge of interest in developing oil shale, primarily at the political level. The development of oil shale will potentially require the consumptive use of large amounts of water for oil shale processing, reclamation, necessary electrical power generation, and the associated municipal use by the supporting communities.

The River District, in cooperation with the State of Colorado, and the Colorado River and Yampa/White Roundtables are sponsoring an energy water needs assessment. The first phase final draft report has been issued (URS Inc., 2008) Efforts to complete a second phase study are now underway.

The first phase results shocked many in Colorado's water community. The bottom line is that a large oil shale industry (greater than 1,000,000 bpd) could require the use of all or perhaps more than all of Colorado's remaining unused Colorado River Compact entitlement. Of course, the study authors had to make numerous assumptions concerning technology and where and how the electrical power needed to supply an in-situ technology-based industry will be produced. If the ultimate oil shale

extraction technology is new and different than what is currently under development, the resulting water demands could be smaller.

This issue presents Colorado with a difficult policy challenge. Do we reserve a major portion of our unused water (if we have any) for a future oil shale industry? If we do not, are we willing to live with the consequences of the industry turning to the market (agriculture) to meet its future supply needs? The situation is complicated because the energy companies already hold valid conditional water rights (rights not yet perfected by use). If the industry develops its relatively senior rights, the results could be an unacceptable reduction in the yield of existing perfected water systems, including many trans-mountain diversions.

Three Strategies to Help Manage Uncertainty

To help manage these uncertainties I suggest three broad strategies.

1. Early identification, acceptance, and prioritization of unacceptable outcomes

The compilation of a list of unacceptable outcomes is probably very easy. Every stakeholder will have its own list. The problems and challenges are reaching a consensus on prioritizing the list and identifying a plan to meet priority needs.

Within the Basin, we all know that there are events we accept as model output but really understand will never happen. For example, would a future Secretary of the Interior ever let Lake Mead drop below the minimum level necessary to deliver water to Las Vegas? The answer is almost certainly no. However, unless Arizona, California, the Upper Basin, and the other parties get something they want in return, will they publicly acknowledge this reality? I believe that most parties acknowledge that human health and safety is the top priority. What happens if there is insufficient water to meet all identified health and safety needs? What if the cost of meeting this top priority is considered unacceptably high for the other uses and resources? At what point can the Basin no longer support human health and safety, critical environmental uses, and minimal quality of life needs such as urban trees and parks? What happens

if the owners of the most senior rights say “no more”?

2. Maintain positive relationships among the stakeholders

Again, this task is probably easier said than done. In the Upper Basin, the 1948 Compact created an Upper Basin Commission. This Commission has served a bonus role of fostering good relations and effective communications among the Upper Basin States. However, no similar organization exists in the Lower Basin or the Basin as a whole.

In recent years, the States have done reasonably well in working out consensus solutions, but the States have been criticized for excluding other stakeholders. Additionally, the motivation has most often been the threat of a unilateral decision by the Secretary. The future challenges may overwhelm voluntary cooperation among the States. Based on history, we need to acknowledge that the courts, primarily the United States Supreme Court, have provided a useful dispute resolution forum, but using the courts for dispute resolution is both expensive and time consuming. The 1964 Arizona v. California decision took over a decade to resolve. The recent Arkansas River dispute between Colorado and Kansas was almost two decades long. Finally, courts can make decisions and interpret laws and compacts, but they cannot provide practical and long-lasting solutions. At the end of any future litigation on the Colorado River, the parties would still have to work out cooperative and practical solutions.

3. Better integration of science into decisionmaking

Again, this is a goal that can be readily agreed to by most stakeholders. The real challenge is implementation.

In recent years we have made some progress. For example, Reclamation's shortage criteria Environmental Impact Statement (EIS) included a nontraditional hydrology appendix. The analysis examined how the system would operate based on the long-term reconstructed gage record at Lee Ferry and stochastic hydrology techniques. While the data were made available, I am not sure it became a part of the dialogue among the States or of the policy decisionmaking process.

In Colorado, we are aggressively pursuing new science-based studies. A number of major water providers are conducting a Front Range climate change vulnerability assessment. The Colorado Water Conservation Board is conducting a Colorado River water supply availability study that will look at vegetation changes, paleohydrology, and climate change. Again, the big question is how will we use this information?

I believe that the reality is that we now must consider two new concepts into our water system planning and management. First, we should not assume that the future will look like the past. In fact, we should plan for a number of reasonably foreseeable alternate futures. Reasonable futures include a Colorado River with reduced streamflows from climate change, a future with a significant oil shale industry, a future where there is a huge worldwide demand for U.S. agriculture, a future where public health requires ultrapure drinking water, and a future with many or all of the above. Can we develop a strategy that does not result in unacceptable outcomes under any of the possible futures?

Second, there is no such thing as the once hallowed concept of system firm yield. We must assume that natural water systems are dynamic and we must consider a range of possible outcomes in terms of probabilities.

When I refer to water system planning and management, I include ecosystem management, fisheries, wildland fire strategies—not just the traditional water systems for human purposes.

To accomplish this task, we need more effective communications among the science community, the water management professionals, and policy makers. Since these three groups have different goals and do not always candidly speak the same language, effective communication will require continued work. We have had some major some recent successes: the efforts of the Western Water Assessment and CLIMAS are examples.

Finally, I want to suggest that we cannot forget the basics, primarily good water system data collection and access, but also streamflow measurements,

stream temperature, water quality, basic watershed weather data, consumptive use data, and changes to the vegetation within our watersheds. The collection and analysis of basic data will be fundamental to our understanding of the Colorado River system and for future management decisions. If we do not know the baseline, how can we understand the effects of climate change? How can we evaluate the effects of augmentation plans, such as cloud seeding? There is no substitute.

References

- Christiansen, N., and D. Lettenmaier. 2006. A multimodel ensemble approach to assessment of climate change impacts on the hydrology and water resources of the Colorado River basin. *Hydrology and Earth System Sciences Discussions* 3:3,727–3,770.
- Colorado Water Conservation Board. 2008. Climate change in Colorado—A synthesis to support water resources management and adaptation. Report for the Colorado Water Conservation Board.
- Garfin, G., and M. Lenant. 2007. Climate change effects on southwest water resources. *Southwest Hydrology Magazine* 6(1):16–17, 34.
- National Research Council. 2007. Colorado River Basin Water Management—Evaluating and Adjusting to Hydroclimatic Variability. National Research Council of the National Academies.
- URS, Inc. 2008. Final Draft Energy Water Needs. Report prepared for the Yampa/White and Colorado Mainstem Roundtables, September 2008.
- U.S. Bureau of Reclamation. 2007. Draft Environmental Impact Statement: Colorado River Interim Guidelines for Lower Basin Shortages and Coordinated Operations for Lake Powell and Lake Mead—Appendix N: Analysis of Hydrologic Variability Sensitivity. [Data obtained from direct paleo trace, 1620 to 1674]. U.S. Department of the Interior, Bureau of Reclamation, Lower Colorado Region.
- Woodhouse, C.A., S.T. Gray, and D.M. Meko. 2006. Updated streamflow reconstructions for the Upper Colorado River Basin. *Water Resources Research* 42:W05415.

Adaptive Management of Watersheds and Related Resources

Byron K. Williams

Abstract

The concept of learning about natural resources through the practice of management has been around for several decades and by now is associated with the term adaptive management. The objectives of this paper are to offer a framework for adaptive management that includes an operational definition, a description of conditions in which it can be usefully applied, and a systematic approach to its application. Adaptive decisionmaking is described as iterative, learning-based management in two phases, each with its own mechanisms for feedback and adaptation. The linkages between traditional experimental science and adaptive management are discussed.

Keywords: adaptive management, conservation, decisionmaking, learning, natural resources, uncertainty

Introduction

Adaptive management (AM), a framework for learning about natural resources through management interventions, has been a part of natural resources thinking for several decades under the generic guise of learning-based management (Beverton and Holt 1957). Holling (1978) and Walters and Hilborn (1978) were the first to provide the name and conceptual framework for adaptive management of natural resources, and Walters (1986) gave a more complete technical treatment of adaptive decisionmaking. Lee (1993) then expanded the context for adaptive management in terms of its social and political dimensions. Because of these and other efforts, many in natural resources conservation now claim, often with only limited justification, that AM is the approach they commonly use in meeting their resource management responsibilities (Failing et al. 2004).

Williams is Chief of the Cooperative Research Units for the U.S. Geological Survey Biological Resources Discipline, Reston, VA 20192.

The scientific and management literature documents considerable variation in the definition and framing of AM. However, almost all definitions incorporate the twin ideas of uncertainty as to the consequences of management and decisionmaking in the face of that uncertainty. A simple definition of AM that captures these essential features is “learning through the process of management itself, with adjustment of management actions based on what’s learned.” Even more succinctly, AM can be described as learning by doing and adapting based on what is learned. The key concepts in these definitions are learning (the improvement in understanding through time) and adaptation (the adjustment of management strategy through time as conditions evolve). The natural consequences of such an approach are to improve understanding of the resource system being managed and to improve resource management based on that improved understanding.

Framework for Adaptive Management

The context for learning-based resource management involves natural resources that respond to changing environmental conditions and management strategy, with management effectiveness constrained by a limited understanding about resource impacts. Uncertainty about management impacts often is tied to specific processes that control resource dynamics (e.g., reproduction, mortality, movement), vital rates that parameterize these processes, or linkages among processes across ecological or geographic scales. One consequence of this uncertainty is a potential for disagreement about the most appropriate management strategy.

Figure 1 shows a dynamic resource system that is subjected to management actions and fluctuating environmental conditions through time. Environmental conditions in the figure might include exogenous factors such as seasonal temperatures, precipitation, cloud cover, and light intensity that fluctuate through

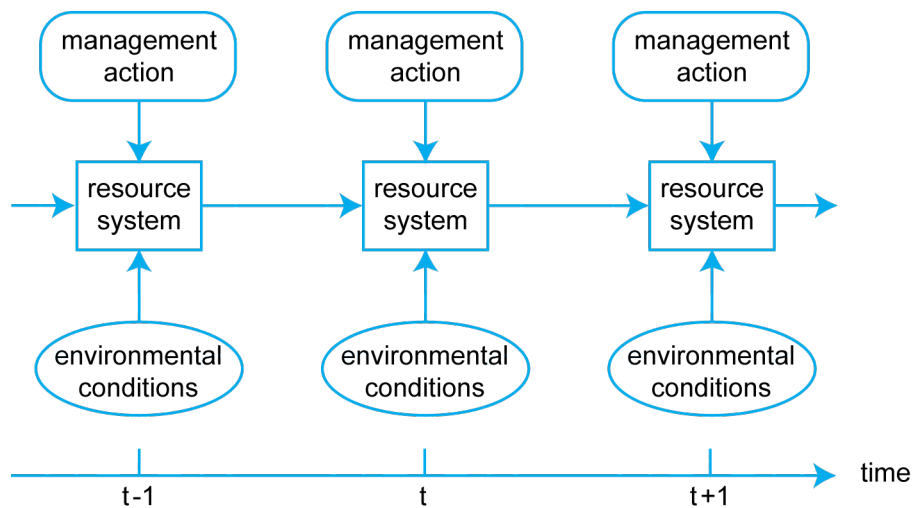

Figure 1. Dynamic resource system, with changes influenced by fluctuating environmental conditions and management actions. Management typically produces short-term returns (costs and (or) benefits) and longer-term changes in resource status.

time, inducing fluctuations in resource status and altering the processes that drive resource dynamics. Potential management actions can be of many different kinds, but they typically focus on resource inputs (e.g., fish stocking), outputs (e.g., water release), or processes (e.g., habitat alterations that affect reproductive success). Finally, resource states are seen

Management interventions in AM are seen as experiments, with the tracking and assessment of resource responses providing experimental results on which to base future management. It is for this reason that AM often is described as “science-based” management. Science and decisionmaking play complementary roles in the overall enterprise, even though science in a context of AM inherits its value from its contribution to improving management. Thus, science supports management by providing information for decisionmaking; but management also supports science with interventions that are designed for scientific investigation. In fact, AM is defined by this bi-directional support with an overall goal of reducing uncertainty and improving management.

A great many (but not all) natural resources under Federal and State jurisdiction are subject to the kind of iterated decisionmaking illustrated in Figure 1. Examples might include agricultural and grazing lands, managed wetlands, ecosystems subjected to fire management, forested wildlife habitat, commercial fisheries, impounded hydrologic systems, and watersheds in a working landscape. The presence of

as evolving through time, in response to changing environmental conditions and management actions. Management at any point in time is seen as potentially influencing resource dynamics from that time forward. A key feature of AM is uncertainty as to the magnitude and direction of resource changes induced by management actions.

uncertainty about management consequences complicates decisionmaking for these resources and creates the potential for disagreement and controversy among stakeholders.

Conditions That Warrant the Use of Adaptive Management

Not all decisions can or should be adaptive, and in fact several conditions must be met to justify an adaptive approach. First and most fundamentally, management through time is required, even though its effect is uncertain. That is, a problem must be important enough that management actions must be taken, though their consequences cannot be predicted with certainty.

A second condition is that clear and measurable objectives can be identified, by which to guide the decisionmaking process. The articulation of objectives plays a key role in AM, in performance evaluation as well as decisionmaking.

Third, there must be the flexibility to use learning to adjust management. Among other requirements are an

acceptable range of management alternatives from which to select actions, and a management environment that is flexible enough to allow adaptations as understanding accumulates through time.

Fourth, there must be a potential to improve management performance by reducing uncertainty. It is the prospect of more efficient and effective decisionmaking that ultimately justifies AM. Conversely, an adaptive approach is not warranted if potential improvements in management are insufficient to justify the costs of acquiring the needed information.

A fifth condition is that monitoring can be used to reduce uncertainty. The analysis and assessment of monitoring data produce an understanding of system processes, and thus an opportunity to improve management. Without periodic monitoring of the appropriate resource attributes, the learning on which to base informed management adjustments is not possible.

Finally, most expositions on AM recognize the importance of a sustained commitment by stakeholders and managers. Stakeholders should be continuously and actively involved in an AM project, from the identification of its objectives and management

alternatives to the expression of uncertainty and the collection and analysis of monitoring data (Lee 1999).

It should be clear from the foregoing that there are many problems for which adaptive management may not be a useful approach. On the other hand, there are many problems involving cooperative management of dynamic resources that may be usefully addressed with AM. Included in the latter are management issues involving ecological landscapes, hydrologic systems, and, notably, watersheds. In fact, fisheries, riverine systems, and other aquatic resources have been important focus areas for many years, largely because of the dynamic nature of these resources and the influence of management on them.

The sequence of activities shown in Figure 2 often is used to characterize AM. It is useful to think of the sequence as beginning with problem assessment, followed by planning, implementation, evaluation, and eventual reassessment in an ongoing cycle. Additional structure can be incorporated into this sequence by recognizing an embedded feedback loop of monitoring, evaluation, and management that focuses specifically on technical learning about the effects of management. The overall cycle, which may include multiple iterations of this imbedded loop, incorporates the potential for learning about the adaptive process itself through periodic problem reassessment, design, and implementation.

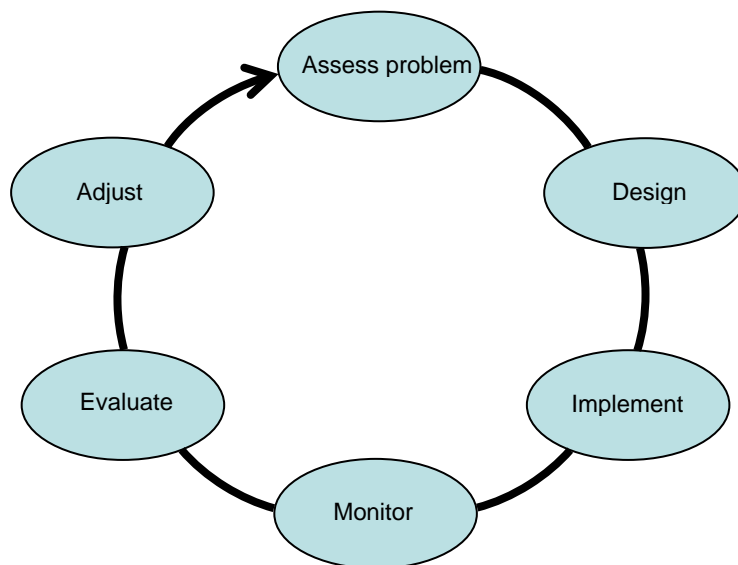

Figure 2. Diagram of the adaptive management process. It is convenient to think of the process as beginning with problem assessment and repeating the cycle as needed to improve resource understanding and management.

Adaptive Management Implementation

One way to describe the implementation of AM is in terms of a deliberative setup phase in which key components are put in place, and an iterative action phase in which they are linked together in a sequential decision process (Norton 2005, Williams et al. 2007). The action phase utilizes the elements of the deliberative phase in an ongoing cycle of learning about system structure and function and managing based on what is learned (Figure 3).

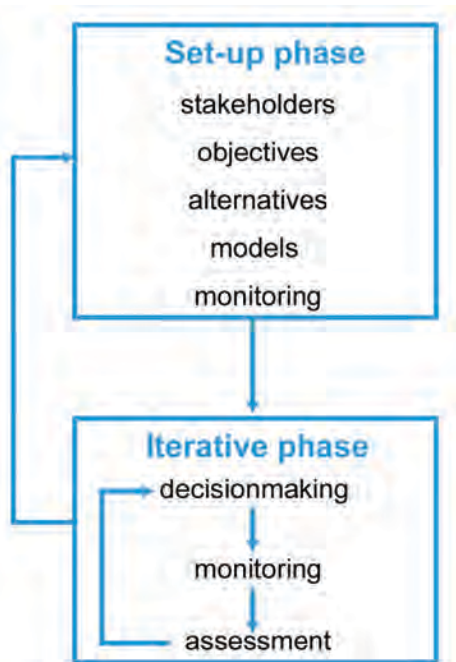

Figure 3. Two-phase implementation of adaptive management. In the deliberative setup phase, key elements of adaptive management are put in place. In the iterative action phase, these elements are folded into an ongoing process of decisionmaking, follow-up monitoring, and assessment of monitoring data. Adaptive management focuses on ecological understanding in the action phase and process learning in the deliberative phase through periodic re-assessment of process elements.

Deliberative phase

In the deliberative setup phase of the AM process, the components of AM are identified and periodically refined as needed. Key process elements include the following.

Stakeholder involvement

A key step in any AM application is to engage the appropriate stakeholders and ensure their ongoing involvement in the process (Wondolleck and Yaffe 2000). Of particular importance is the participation of stakeholders in assessing the resource problem and reaching agreement about its scope, objectives, and potential management actions. By defining the operating environment of an AM project, stakeholders directly influence both decisionmaking and the opportunity to learn.

Objectives

Objectives, resource status, and learning all influence the choice of management interventions in adaptive management. But objectives also play a crucial role in evaluating performance, reducing uncertainty, and improving management through time. Clear, measurable, and agreed-upon objectives are key to guiding decisions and assessing progress in achieving management success.

Management actions

Like any iterative decision process, adaptive decisionmaking involves the selection of an appropriate management action at each decision point, given the status of the resources being managed at that time. Resource managers and stakeholders, typically working with scientists, have the responsibility of identifying the potential actions from which this selection is made.

Predictions

Predictive models play an important role in AM by linking potential management actions to ecological consequences. One example is the use of models to help in the selection of management actions, through the comparison of management alternatives in terms of their anticipated costs, benefits, and resource consequences.

Predictive models also play a key role in representing uncertainty, with contrasting hypotheses about system structure and function imbedded in different models that are used to forecast resource changes through time. At any point, the available evidence will suggest differences in the adequacy of these models to represent resource dynamics. As evidence accumulates over time, the confidence placed in each model (and its associated hypothesis) evolves through a comparison of model predictions against monitoring data.

Monitoring plans

The learning that is at the heart of AM occurs through a comparison of predicted against observed responses. It is by means of these comparisons that one learns about resource dynamics and thus identifies the most appropriate hypotheses about resource processes and their responses to management. Through the tracking of system responses, well designed monitoring programs facilitate evaluation and learning. Monitoring is much more effective when it targets attributes for these purposes (Nichols and Williams 2006).

Action phase

The operational sequence of AM utilizes the elements identified in the deliberative phase to improve understanding and management (Figure 4). Key steps in the iterative process include the following.

Decisionmaking

At each decision point in the timeframe of an AM project, an action is chosen from the set of available management alternatives. Management objectives are used to guide this selection, given the state of the system and the level of understanding when the selection is made. It is the influence of reduced uncertainty (or increased understanding) on decisionmaking that renders the decision process adaptive.

Follow-up monitoring

Monitoring is used to track system behavior, in particular the responses to management through time.

In the context of AM, monitoring is seen as an ongoing activity, producing data to evaluate management interventions, update measures of model confidence, and prioritize management options in the next time period.

Assessment

The information produced by monitoring promotes learning through the comparison of model predictions against estimates of actual responses. The comparison highlights the degree of coincidence between predicted and observed changes, which in turn serves as an indicator of model adequacy. Confidence increases for models that accurately predict change, and confidence decreases for models that are poor predictors of change.

Assessment also includes the comparison of management alternatives as to their projected costs, benefits, and resource impacts, for use in identifying management strategy itself. Finally, performance assessment, based on the comparison of desired against actual outcomes, includes the evaluation of management effectiveness and measurement of success in attaining management objectives.

Feedback

At any given time, the gain in understanding from monitoring and assessment is used to inform the selection of management actions. As understanding evolves, so too does the decisionmaking that is influenced by improved understanding. In this way, the iterative cycle of decisionmaking, monitoring, and assessment leads gradually to improved management as a consequence of improved understanding.



Figure 4. Action phase of adaptive management. Management actions are based on objectives, resource status, and understanding. Data from follow-up monitoring are used to assess impacts and update understanding. Results from assessment guide decisionmaking at the next decision point.

Double-Loop Learning

Adaptive decisionmaking provides an opportunity to learn about the adaptive process itself by periodic but less frequent recycling through the elements in the deliberative phase (Figure 3). The broader context of learning that recognizes process as well as technical learning is sometimes called “double-loop” learning (Argyris and Shon 1978, Salafsky et al. 2001).

The need to address process learning arises from the fact that stakeholder perspectives and values can shift as the adaptive process unfolds, as previously unanticipated patterns in resource dynamics require an adjustment of objectives, alternatives, and other elements of the process. In this sense, learning needs to focus on changes in institutional arrangements and stakeholder values as well as changes in the resource system. Because these process changes can themselves be a result of experience in pursuing objectives, it is useful to account for them as decisionmaking progresses through time. Indeed, understanding and tracking social and institutional relations and stakeholder perspectives can be as important as the resolution of technical issues about system structure and function (Williams 2006).

A well designed AM project provides the opportunity for learning at both the technical and process level, recognizing that technical and process learning often occur on different scales. Technical learning is promoted through the learning cycle in Figures 3 and 4 in a context of relatively short-term stationarity in objectives, alternatives, and uncertainty factors. Non-stationarity in these process factors is addressed over the longer term, through their periodic but less frequent assessment and adaptation.

Discussion

Adaptive management is described above as an iterative process that gradually leads to improved understanding through the use of management “experiments.” The cycle begins with an assessment and framing of a management issue in which uncertainty is seen as limiting management effectiveness. It then proceeds through design, implementation, evaluation, and management adaptation, with problem reassessment that starts the cycle again (Figure 2). Beneficial consequences of this approach include the joint improvement of

understanding and management through time, recognizing that the primary focus of AM is on long-term management, with science providing the information needed to improve management.

It is useful to contrast the “science-based” approach of AM against traditional scientific investigation, experimental science in particular. Perhaps surprisingly, with some minor renaming of the elements in Figure 2, the cycle of activities shown there also describes experimental science: the scientific process starts with identification of a research question, based on information and understanding accumulated up to the present. An experiment involving experimental treatments and alternative hypotheses about their impacts then is designed to address that question. This is followed by the actual conducting of the experiment in the field or laboratory, during which data are collected and recorded for analysis with, for example, analysis of variance procedures. The analytic results add to our edifice of understanding, but also generate new research questions that must be framed in terms of the new understanding, thereby starting the cycle again.

A few points are worth mentioning. First, the “experimentation” in AM is implemented with experimental treatments that are management interventions. This contrasts with experimental treatments in a context of classical experimental design, which may or may not have anything to do with management interventions.

Second, scientific experimentation and experimental design typically are described in terms of randomization, replication, and experimental controls, which allow for strong inferences based on experimental results (Gauch 2003). In contrast, experimental management often is missing some of these key features; for example, it often is not possible to randomize interventions or replicate them across the landscape. Thus, the inferences from the results often are not as strong as they might otherwise be under more rigorous experimental conditions.

Third, the inferential framework for experimental management differs somewhat from that of classical experiment design, largely because of a difference in focus. Thus, AM ultimately seeks to promote more informed management through learning, whereas traditional experimentation is oriented exclusively to the improvement of understanding. Scientific

experimentation is concerned with contrasts among alternative hypotheses, as reflected in such measures as Type I and Type II error rates. In contrast, AM is more amenable to a decision-theoretic basis of inference, in which the inferential questions focus on which hypothesis can lead to the most effective management strategy.

Some in the scientific community might be concerned that AM, with its strong orientation to management, leaves little room for more basic and curiosity driven scientific investigation. But it is important to recognize that scientific investigation, whether basic or applied science, field or laboratory studies, or development of analysis and estimation protocols, contributes to the overall body of understanding on which all human activities, including AM, are based. Some of that large body of scientific investigation fits comfortably in the context of learning-based management and some does not, but AM is nevertheless a beneficiary, not least because of the very important role that basic science can play in helping to assess and frame the problems to be addressed with AM.

Adaptive management can and should utilize experience accumulated up to the present, whatever its source, in structuring a resource problem, identifying feasible management options, and resolving uncertainties about management impacts. The underlying idea is that a process of using management itself to reduce uncertainties can accelerate learning and lead more rapidly to informed management. But nothing in this process excludes the use of information collected through basic and curiosity-driven science. Just as AM can promote the integration of science and management to the benefit of each, so can it promote the integration of basic and applied science to the benefit of each.

References

Argyris, C., and D. Shon. 1978. *Organization Learning: A Theory of Action Learning*. Addison-Wesley, Reading, MA.

Beverton, R.J.H., and S.J. Holt. 1957. *On the Dynamics of Exploited Fish Populations*. Her Majesty's Stationery Office, London.

Failing, E., G. Horn, and P. Higgins. 2004. Using expert judgment and stakeholder values to evaluate adaptive management options. *Ecology and Society* 9:13. [online] URL:

<http://www.ecologyandsociety.org/vol9/iss1/art13/>. Accessed 14 May 2009.

Gauch, H.G. 2003. *Scientific Method in Practice*. Cambridge University Press, New York.

Holling, C.S., ed. 1978. *Adaptive Environmental Assessment and Management*. Wiley, Chichester, UK.

Lee, K.N. 1993. *Compass and Gyroscope: Integrating Science and Politics for the Environment*. Island Press, Washington DC.

Lee, K.N. 1999. Appraising adaptive management. *Conservation Ecology* 3:3. [online] URL: <http://www.consecol.org/Journal/vol3/iss2/art3>. Accessed 14 May 2009.

Nichols, J.D., and B.K. Williams. 2006. Monitoring for conservation. *Trends in Ecology and Evolution* 21:668–673.

Norton, B.G. 2005. *Sustainability: A Philosophy of Adaptive Ecosystem Management*. University of Chicago Press, Chicago.

Salafsky, N., R. Margoluis, and K. Redford. 2001. *Adaptive Management: A Tool for Conservation Practitioners*. Biodiversity Support Program, Washington DC. [online] URL: www.worldwildlife.org/bsp/.

Walters, C.J. 1986. *Adaptive Management of Renewable Resources*. Blackburn Press, Caldwell, NJ.

Walters, C.J., and R. Hilborn. 1978. Ecological optimization and adaptive management. *Annual Review of Ecology and Systematics* 9:157–188.

Williams, B.K., R.C. Szaro, and C.D. Shapiro. 2007. *Adaptive Management: The U.S. Department of the Interior Technical Guide*. Adaptive Management Working Group, U.S. Department of the Interior, Washington DC.

Williams, B.K. 2006. Adaptive harvest management: Where we are, how we got here, and what we have learned thus far. *Transactions, North American Wildlife and Natural Resources Conference* 71:259–274.

Wondolleck, J.M., and S.L. Yaffe. 2000. *Making Collaboration Work: Lessons from Innovation in Natural Resource Management*. Island Press, Washington DC.

The National Wildlife Refuge System and Resource Management in a Watershed Context

Andy Loranger

Abstract

The National Wildlife Refuge System (NWRS) is a national network of 548 Refuges, 37 Wetland Management Districts, and nearly 7,000 Waterfowl Production Areas. The NWRS encompasses 97 million acres, with at least one National Wildlife Refuge in each state. The NWRS is unique among Federal land management agencies in that our core mission is the conservation of wildlife and wildlife habitat. Key management activities within the Refuge System include providing habitat for breeding and migratory waterfowl, preserving threatened and endangered species, and restoring and maintaining wildlife habitats. Essential to the continued success of these activities, and to the Refuge System mission as a whole, is the maintenance of reliable supplies of clean, fresh water. With the exception of some of our largest refuges, we generally share watersheds with other stakeholders and multiple land uses. Refuges operate within this larger landscape context and usually manage water supplies according to State laws. Protecting water supplies requires a dedicated effort to inventory sources and monitor water quantity and quality. A major challenge for the Refuge System is assessing our water resources nationwide: inventorying water rights and water sources, quantifying use, identifying threats, and evaluating water quality. Such data are particularly lacking for many of our refuges in the eastern States, where competition for water is increasing. Assessing water resource issues from a landscape/watershed perspective is especially important in the East, where State riparian water laws require sharing of available

Loranger is the Chief of the Division of Natural Resources and Conservation Planning, National Wildlife Refuge System, U.S. Fish and Wildlife Service, Arlington, VA 22203.

water supplies among users. Water quality issues are best examined in a watershed context, and we are currently engaging in a pilot program with the Environmental Protection Agency (EPA) and U.S. Geological Survey (USGS) to identify refuge water quality issues within such a landscape perspective.

Keywords: refuge, NWRS, water management, wildlife

Introduction

The National Wildlife Refuge System (NWRS, or Refuge System) is a system of 548 Refuges dedicated to the conservation of wildlife and wildlife habitats. Administered by the U.S. Fish and Wildlife Service, the NWRS is unique among Federal land management agencies in that its core mission is wildlife conservation. The NWRS encompasses 97 million acres, with at least one refuge in each state. In addition, the NWRS manages 37 Wetland Management Districts and nearly 7,000 Waterfowl Production Areas, concentrated primarily in the Prairie Pothole region of the Upper Midwest.

Each refuge was established for a specific purpose or purposes, and these help guide the day-to-day refuge management operations. Many refuges have been established to provide habitat for migratory or breeding waterfowl. At these refuges, the ability to manipulate water levels in wetlands is important in order to provide the habitats necessary at critical times in the birds' annual cycle. In most cases, these manipulations mimic the natural flooding regimes of wetland systems that have been lost or greatly diminished over time.

Another important refuge purpose is the preservation of threatened and endangered species. The Refuge System provides habitat for over 250 Federally-listed plants and animals, and many refuges are actively

involved in maintaining or restoring habitat for these species.

Essential to the continued success of these activities, and to the Refuge System mission as a whole, is the maintenance of reliable sources of clean, fresh water.

Water Management in the Refuge System

With the exception of relatively few refuges with Federal reserved water rights, the NWRS acquires and manages water according to State water laws. Like other users, refuges are subject to the regulations and restrictions on how, where, and when we may use water, as determined by each state.

Water is often described as the “lifeblood” of the Refuge System, but it is also the lifeblood of agriculture, industry, energy production, and municipalities. A major challenge for the NWRS is protecting our existing water supplies and ensuring we have adequate water for the future in the context of increasing human populations and the uncertainties of climate change.

A major task for the Refuge System in the near future will be a nationwide assessment of refuge water resources: inventorying water rights and water sources, quantifying use, identifying threats, and evaluating water quality. Such assessments are particularly lacking at refuges in the eastern United States, where traditionally there has been less emphasis on perfecting water rights than in the more arid West, but where there has been increasing pressure on surface and groundwater supplies. All of these assessments will require hydrological, biological, and legal expertise, some of which currently exist in-house within the NWRS and some we are in the process of developing, especially in the East.

Watershed Issues

Except for some of our largest refuges, we generally share watersheds with other stakeholders and multiple land uses. Our watershed issues and research questions relate primarily to water quantity and quality and how these interact with our refuge management operations on a landscape level. We are mostly a user, rather than a generator, of research.

One particular issue related to both water quality and quantity that the NWRS is encountering with increasing frequency is the use of treated effluent in refuge wetlands. Refuges sometimes receive proposals from municipalities to place such effluent on refuge wetlands in order to further remove organics and nutrients from the water. On the positive side, it may be an opportunity for a refuge with insufficient water supply to increase the amount of water available for wildlife. However, care must be taken that we are not introducing potentially harmful materials, including pathogens, metals, and endocrine-disrupting compounds, into refuge waters. This is an area where further research and specific guidance are necessary.

Because refuges often share watersheds with other landowners, water quality issues may arise from either materials entering the refuge from adjacent land uses, or materials leaving the refuge and affecting downstream users. An example of the former is Horicon NWR in southern Wisconsin. The refuge occupies the northern 21,000 acres (8,500 ha) of the 32,000-acre (12,950-ha) Horicon Marsh. The marsh is situated in the West Branch of the Rock River, in a landscape dominated by intense agriculture. The marsh and the refuge have received 10,000 tons of sediment and significant influxes of nitrogen and phosphorus. It is estimated that over 85 tons of phosphorus have been deposited into the marsh. These nutrients have caused significant changes in the vegetation community—resulting primarily in monocultures of cattails—and have reduced a once healthy fishery into one dominated by invasive carp. The refuge has partnered with the State, other Federal agencies, and private landowners to reduce the sediment and nutrient loads entering the marsh, but because we lack sufficient funds to adequately monitor water quality, progress has been difficult to measure.

Watershed issues that the Refuge System has faced highlight the importance of working with other stakeholders. This is particularly important with regard to water quantity issues in the East, where riparian water laws require sharing of water supplies. At Silvio O. Conte NWR in Massachusetts, the refuge partnered with Smith College, four local governments, the University of Massachusetts Cooperative Extension unit, and private landowners in the watershed to demonstrate that the proposed water withdrawals for a local bottling plant would diminish flows in the Mill River and affect endangered mussels. The plant was

allowed to operate, but with restrictions on daily withdrawals.

Other examples of refuges partnering to address watershed issues include the Hanalei NWR working with the Hanalei Watershed Hui, a local nonprofit group, to improve sanitary septic systems on the refuge and to address water quality issues on the Hanalei River. Also, Bitter Lake NWR in New Mexico is partnering with several governmental and non-governmental organizations to restore habitats along the Pecos River.

Addressing Water Quality Issues at a Landscape and Watershed Scale

The NWRS has recently collaborated with the U.S. Environmental Protection Agency (EPA) and the U.S. Geological Survey (USGS) to look at the relationship of impaired waters with National Wildlife Refuges. As states identify impaired waters and develop total maximum daily loads (TMDLs) to address these impairments, refuges may be put in a position to alter their management operations in order to comply with TMDL regulations.

Collaboration with EPA will allow us to examine the geospatial relationships of impaired waters with refuge boundaries and identify refuges where water quality issues may arise. We will then be in a position to prioritize research into the causes of impairment, and the USGS will assist us in examining landscape and watershed factors in this regard. This research will allow us to identify and address water quality issues in refuges and provide wildlife with quality habitats.

Conclusions

Water is indeed the lifeblood of the National Wildlife Refuge System, a Federal system of lands dedicated to conservation of wildlife and wildlife habitats. Assessing and protecting our water supplies now and in the face of future climate uncertainties is a major challenge for the Refuge System. Because refuges are often integrated into a diverse landscape, an integral component in protecting water quantity and quality is working with other stakeholders in a watershed context. Although such an approach is not always successful at resolving issues or completely eliminating conflicts, we feel it is the best first step in addressing landscape-level water quality and quantity issues.

Selected Achievements, Science Directions, and New Opportunities for the WEBB Small Watershed Research Program

Pierre D. Glynn, Matthew C. Larsen, Earl A. Greene, Heather L. Buss, David W. Clow, Randall J. Hunt, M. Alisa Mast, Sheila F. Murphy, Norman E. Peters, Stephen D. Sebestyen, James B. Shanley, John F. Walker

Abstract

Over nearly two decades, the Water, Energy, and Biogeochemical Budgets (WEBB) small watershed research program of the U.S. Geological Survey (USGS) has documented how water and solute fluxes, nutrient, carbon, and mercury dynamics, and weathering and sediment transport respond to natural and human-caused drivers, including climate, climate change, and atmospheric deposition. Together with a continued and increasing focus on the effects of climate change, more investigations are needed that examine ecological effects (e.g., evapotranspiration, nutrient uptake) and responses (e.g., species abundances, biodiversity) that are coupled with the physical and chemical processes

Glynn is Branch Chief for the Water Resources National Research Program, Eastern Region, U.S. Geological Survey (USGS), Reston, VA 20192. Larsen is Associate Director for Water, USGS, Reston, VA 20192. Greene is Staff Assistant to the Chief Scientist for Hydrology, USGS, Reston, VA 20192. Buss is a postdoctoral Research Associate, USGS, Menlo Park, CA 94025. Clow and Mast are Research Hydrologists, USGS, Denver, CO 80225. Hunt and Walker are Research Hydrologists, USGS, Middleton, WI 53562. Murphy is a Hydrologist, USGS, Boulder, CO 80303. Peters is a Research Hydrologist, USGS, Atlanta, GA 30360-2824. Sebestyen is a Research Hydrologist, U.S. Forest Service, Grand Rapids, MN 55744. Shanley is a Research Hydrologist, USGS, Montpelier, VT 05602. Emails: pglynn@usgs.gov; mclarsen@usgs.gov; eagreene@usgs.gov; hlbuss@usgs.gov; dwclow@usgs.gov; mamast@usgs.gov; rjhunt@usgs.gov; jfwalker@usgs.gov; sfmurphy@usgs.gov; nepeters@usgs.gov; ssebestyen@fs.fed.us; jshanley@usgs.gov.

historically observed in the WEBB program. Greater use of remote sensing, geographic modeling, and habitat/watershed modeling tools is needed, as is closer integration with the USGS-led National Phenology Network. Better understanding of process and system response times is needed. The analysis and observation of land-use and climate change effects over time should be improved by pooling data obtained by the WEBB program during the last two decades with data obtained earlier and (or) concurrently from other research and monitoring studies conducted at or near the five WEBB watershed sites. These data can be supplemented with historical and paleo-environmental information, such as could be obtained from tree rings and lake cores. Because of the relatively pristine nature and small size of its watersheds, the WEBB program could provide process understanding and basic data to better characterize and quantify ecosystem services and to develop and apply indicators of ecosystem health. In collaboration with other Federal and State watershed research programs, the WEBB program has an opportunity to contribute to tracking the short-term dynamics and long-term evolution of ecosystem services and health indicators at a multiplicity of scales across the landscape.

Keywords: biogeochemistry, climate, ecohydrology, ecosystem indicators, ecosystem services, experimental forests, experimental watersheds, LTER, WEBB

Program Background and Achievements

Scientists in the [WEBB](#) (Water, Energy, and Biogeochemical Budgets) program of the U.S. Geological Survey (USGS) have been monitoring and conducting hydrologic-process research at five small

watershed sites across the United States since 1991: Luquillo, PR; Panola Mountain, GA; Sleepers River, VT; Trout Lake, WI; and Loch Vale, CO (Baedecker and Friedman 2000, Baedecker 2003). The cumulative database now contains 18 years of observations of hydrology (streamflow, groundwater levels, and soil moisture), meteorology (precipitation, temperature, humidity, and wind speed and direction), and water quality (including major solutes, nutrients, stable environmental isotopes, mercury and methylmercury, and organic carbon). This long-term effort has successfully explained and quantified many of the hydrological and biogeochemical processes in these watersheds, which have very different soils, relief, and climate. The WEBB program provides an excellent example of the importance of long-term environmental monitoring (such as argued by Lovett et al. 2007). Important differences in water and solute fluxes and in mercury deposition and cycling have been revealed through comparisons of monitoring and modeling results. Although not the sole research focus when initiated, the WEBB watersheds also have served as sentinels of global change, providing a record of climatic and anthropogenic effects on hydrologic and biogeochemical processes. Examples of global change effects considered by the WEBB program include:

- Timing of streamflow and snowmelt (D. Clow, 2008, "Changes in the timing of snowmelt and streamflow in Colorado: A response to recent warming," USGS, written commun.);
- Loss of alpine permafrost (Clow et al. 2003a) and the relation between snowpack and solute chemistry;
- Wetland carbon gas exchanges (Wickland et al. 2001) and snowpack and tundra carbon gas fluxes (Mast et al. 1998);
- Carbon sequestration (Huntington 1995);
- Dissolved organic carbon fluxes (Schuster et al. 2004) and implications for methylmercury fate and transport;
- Water fluxes and chemical trends (Aulenbach et al. 1996, Peters et al. 2002);
- Response of watershed hydrology (Hunt, Walker, et al. 2008a; Walker et al., this volume) and ecology (Hunt, Walker, et al. 2008b);
- Soil-calcium depletion (Huntington 2000, Huntington et al. 2000, Peters and Aulenbach, this volume); and

- Rock-weathering rates (White and Blum 1995 a and b; White et al. 1999) and mass-wasting and landslides (Carter et al. 2001).

USGS Fact Sheets for each of the five WEBB sites and a synthesis paper for the entire WEBB program provide a retrospective on some of the processes listed above and their trends over the last two decades (D. Clow, USGS, oral commun.). Information about the WEBB program is available at the program's website, <http://water.usgs.gov/webb>.

The small size of the WEBB program watersheds (ranging from 41 to 12,000 ha) has allowed detailed investigation of hydrological and biogeochemical processes that would not have been possible in larger watersheds. Because of its montane and alpine environments, limited forest cover (5 percent), and extensive tundra, talus, and rock and snow glaciers, the Loch Vale site is exceptionally sensitive and responsive (i.e. not resilient) to atmospheric anthropogenic contamination and to climate change. Research at the Loch Vale site has taken advantage of this sensitivity by investigating, for example, (1) the effects of climate on weathering rates (Clow and Drever 1996), and (2) the effects of nitrogen deposition, much of it of anthropogenic origin, on the diatom community in the lake (Baron et al. 2005). Clow et al. (2003a) also found that warming climate and melting permafrost are affecting groundwater flow and solute fluxes at the site and are exposing soils that have a surprising amount of microbial activity. Atmospheric inputs and the changing chemistry of Loch Vale have been compared with deposition and changes in other high-elevation glacial lakes (Clow et al. 2003b, Ingersoll et al. 2008). As part of Rocky Mountain National Park, the Loch Vale site is a UNESCO* International Biosphere Reserve and is also one of the sites monitored under the National Acidic Precipitation Assessment Program (NAPAP), a cooperative Federal program authorized in 1980.

The Sleepers River watershed in Vermont, a research site that was established in 1958 by the Agricultural Research Service (ARS), has been the focus of detailed hydrological and biogeochemical investigations in a mixed land-use setting (forests, agricultural lands, and low-density residential). Dunne and Black (1970)

* United Nations Educational, Scientific, and Cultural Organization

developed the variable source-area concept at the Sleepers River watershed and studied dynamic subsurface and surface flow processes that control the movement of water from the landscape to a stream. Subsequent studies have quantified how preferential flow paths control stream hydrochemical responses during stormflow (Kendall et al. 1999, McGlynn et al. 1999, Shanley et al. 2003, Sebestyen et al. 2008). Studies have traced variable sources and biogeochemical transformations that control the chemical speciation and concentrations of a wide range of stream solutes including nitrogen (Sebestyen et al. 2008), carbon (Doctor et al. 2008, Sebestyen et al. 2008), mercury (Shanley, Mast, et al. 2008), sulfur (Shanley et al. 2005; Shanley, Mayer, et al. 2008), and weathering products (Bullen and Kendall, 1998, Shanley et al. 2002). In addition, the timing, intensity, and character of organic carbon transport at the site has been studied (Sebestyen et al. 2008, Schuster et al. 2008) and contrasted to carbon transport processes in the Yukon River Basin (Schuster et al. 2004). Acidic deposition effects at the site have also been studied extensively and have been contrasted with those occurring in other watersheds. For example, Shanley et al. (2004) compared acid deposition effects in the Sleepers River watershed with those in a watershed in the Czech Republic. The long-term data from Sleepers River have frequently been included in regional assessments of northeastern United States watersheds to quantify nutrient budgets and understand sources and sinks of biogeochemically active solutes (Hornbeck et al. 1997; Campbell et al. 2000, 2004).

The Trout Lake site in northern Wisconsin is part of the North Temperate Lakes Long-Term Ecological Research (LTER) site, one of 26 LTER sites established in 1980 that are funded by the National Science Foundation (NSF). Because of the relatively flat topography and northern temperate climate, this watershed ecosystem is dominated by groundwater flow. Research at the site has focused on surface/groundwater interaction at local to watershed scales. Hydrologic modeling tools were used to: (1) better delineate the groundwater watershed (Hunt et al. 1998), (2) simulate surface/groundwater interactions (Hunt et al. 2003, Hunt 2003), and (3) evaluate the utility of different types of field data for model calibration and prediction (Hunt et al. 2005, Hunt and Doherty 2006, Doherty and Hunt 2009). Novel applications of isotope and ion chemistry were used to investigate lake/groundwater interactions (Krabbenhoft

et al. 1994, Walker et al. 2007) and groundwater flow paths (Walker and Krabbenhoft 1998; Pint et al. 2003; Walker et al. 2003; Fienen et al., in press). Flow-path processes were characterized from the unsaturated zone starting points (Hunt, Prudic, et al. 2008), through the saturated aquifer (Bullen et al. 1996), to hyporheic discharge locations (Schindler and Krabbenhoft 1998, Lowry et al. 2007). This understanding of surface/groundwater interactions provided the foundation for site-scale evaluations of temperature modulation, nutrient concentrations, and invertebrate populations (Hunt et al. 2006), as well as response of the watershed hydrology (Hunt, Walker, et al. 2008a; Walker et al., this volume) and ecology (Hunt, Walker, et al. 2008b) to climatic change.

The Panola Mountain watershed in Georgia is located 25 km southeast of Atlanta in the Panola Mountain State Conservation Park. The watershed has a large impervious area (greater than 10 percent of the watershed) that is provided by granitic bedrock outcrops. This feature has led to a comparison with urbanized watersheds in the Atlanta area (N.E. Peters, 2008, USGS, written commun.). Since 1985, research at the Panola Mountain Research Watershed (PMRW) has improved the conceptual understanding of the watershed's response to precipitation over a range of temporal and spatial scales (McDonnell et al. 1996, Freer, McDonnell, et al. 2002, Peters et al. 2003a, Tromp-Van Meerveld et al. 2007) and has investigated the impact of different hydrologic pathways on solute transport (Peters 1989, 1994; Hooper et al. 1990, 1998; Shanley 1992; Shanley and Peters 1993; Huntington et al. 1994; Aulenbach et al. 1996; Burns et al. 1998, 2001, 2003; Peters et al. 1998; Peters and Ratcliffe 1998; Aulenbach and Hooper 2001, 2006; Hooper 2003; Webb et al. 2003; Peters and Aulenbach, this volume). Research at PMRW has investigated biogeochemical cycling, mercury and sulfur dynamics, dry deposition processes and vegetation transpiration effects on soil moisture content. Hillslope studies quantified the importance of bedrock topography in controlling subsurface stormflow (Freer et al. 1997; Freer, Beven, et al. 2002) and of bedrock leakage in dominating the hillslope water balance (Tromp-van Meerveld et al. 2007). In addition to the development of a detailed hydrologic and biogeochemical conceptual model, the availability of detailed long-term hydrologic measurements is a prerequisite for deterministic hydrologic modeling (Freer, McDonnell, et al. 2002; Peters et al. 2003b; Clark et al. 2008) and detailed

assessments of hillslope and catchment hydrologic behavior (Tromp-van Meerveld and McDonnell 2006c), in particular during rainstorms (Peters et al. 2003a, Tromp-van Meerveld and McDonnell 2006 a and b). Climate impacts are expected because watershed and hillslope stormflow water yields at PMRW are non-linearly related to soil moisture content, rainfall, and water-table elevation, and the relations vary on a seasonal basis.

The Luquillo WEBB project has evaluated hydrologic, chemical, and sediment processes and budgets in four watersheds of differing geology (granitic versus volcanic) and land use (mature rainforest versus agricultural legacy). The forested catchments are located in the U.S. Forest Service (FS) Luquillo Experimental Forest, part of which has been designated a UNESCO International Biosphere Reserve and belongs to the NSF LTER network. The Luquillo WEBB watersheds are undergoing rapid change, both locally induced (including landcover change, species introductions, water resource management) and externally driven (including climate change and long-range advection of pollutants). The Luquillo WEBB program has investigated the effects of hurricanes, atmospheric pollution, drought, climate change, precipitation patterns, and land use on hydrology and water quality (Scatena and Larsen 1991; Zack and Larsen 1994; Larsen 2000; Stallard 2001; Shanley et al. 2008 a and b; Murphy and Stallard, this volume). Research at the Luquillo site has investigated the possible causes of amphibian decline (Stallard 2001) and has contributed to an understanding of the dynamics of cloud forest hydrology, extending previous work conducted on Hawaii (Scholl et al., in press) and detailing the relative importance of orographic and convective precipitation regimes to forested mountain watersheds (M. Scholl (USGS), J.B. Shanley (USGS), J.P. Zegarra (University of Puerto Rico in Mayaguez), and T.B. Coplen (USGS), 2008, "A new explanation for the stable isotope amount effect using NEXRAD echo tops: Luquillo Mountains, Puerto Rico," written commun.). Extensive work on mass wasting has teased out the importance of several factors affecting landslides, including rainfall intensity and duration, historical land use, and road construction (Larsen and Simon 1993, Larsen and Parks 1997, Larsen and Torres-Sanchez 1998, Larsen et al. 1999, Larsen and Santiago-Román 2001, Gellis et al. 2006). Studies of weathering and solute fluxes have been performed in the Icacos watershed, which has one of the highest

documented chemical weathering rates of granitic rocks in the world (Brown et al. 1995, 1998; White and Blum 1995 a and b; Dong et al. 1998; Murphy et al. 1998; White et al. 1998; Schulz and White 1999; Turner et al. 2003; Buss et al. 2004, 2005, 2008; Fletcher et al. 2006; Chabaux et al. 2008). Analyses of sediment and solute concentrations in the Luquillo WEBB rivers and soil porewaters have revealed that fluxes are dominated by storm effects (Peters et al. 2006, Kurtz et al. 2004), indicating that climate change-related perturbations in storm patterns would seriously affect sediment and solute fluxes from the Luquillo WEBB watersheds. Luquillo WEBB studies have also evaluated methane emissions from reservoirs (Joyce and Jewell 2003) and mercury and methylmercury deposition (Shanley, Mast, et al. 2008).

In addition to funding research at individual sites, projects in the WEBB program have developed models, tools, and theories to help understand and quantify hydrologic and biogeochemical processes in small watersheds. For example, the program has spurred the development and application of watershed models such as the Precipitation Runoff Modeling System (PRMS; Leavesley et al. 2005), the Water, Energy, and Biogeochemical Model (WEBMOD; Webb et al. 2006), and GSFLOW (Markstrom et al. 2008), which is the new USGS surface/groundwater interactions model that couples the USGS groundwater flow model MODFLOW with PRMS. The program also has provided a forum for development and testing of methods, such as flux computations (Aulenbach and Hooper 2001, 2006), water-quality sampling (Peters 1994), and dry deposition (Cappellato and Peters 1995). The WEBB program also has stressed the need for watershed comparison studies, especially amongst the five WEBB watersheds. Some of the key comparative studies published include: (1) a principal-component analysis used to identify the statistical relations between hydrologic conditions and the net exports of major cations, anions, and silica at the five sites (Webb et al. 2003); (2) a mass-balance comparison of water and major-solute fluxes monitored at the five watersheds between 1992 and 1997 (Peters et al. 2006); and (3) a comparison of mercury and methylmercury deposition, cycling, and transport in the WEBB watersheds (Shanley, Mast, et al. 2008).

What Are Some of the Future Directions for the WEBB Program?

Federal science priorities in general, and USGS science priorities in particular, have become refocused on climate change issues, in part because of the recent release of the [Intergovernmental Panel on Climate Change \(IPCC\) 4th Assessment Report](#). A wealth of data has been collected in the last 18 years at the WEBB watersheds, and historical data are available for many of the sites prior to the establishment of the WEBB program. The data are being analyzed through an intersite comparison study to examine the effects of climatic trends and variations in temperature and precipitation, in water storage and fluxes, and in nutrient and major solute cycling in the five watersheds.

During the next 5 years, WEBB research plans to take advantage of the gradients in climate, land use, and basin physical characteristics inherent to the five WEBB sites. Water availability under changing climate is a key issue, with potential effects on agriculture, industry, and quality of drinking water. To study the effects on water availability, plans are to evaluate the response of runoff, groundwater flow, and evapotranspiration to variations in climate, and to conduct hydrologic modeling under various climate change scenarios, thereby putting site results in a regional context. The hydrologic and chemical responsiveness of catchments to climate change and atmospheric deposition of pollutants are strongly influenced by water residence times. Residence times could be quantified through a multi-tracer (CFCs, tritium, water isotopes) approach that permits characterization of slow, medium, and fast flow pathways through the catchments; the temporal variability of stream-water residence times can also be assessed with respect to climate change/variability and compared among sites. Trends in climate, runoff, and streamwater chemistry will be evaluated with the objective of establishing the response of runoff and chemistry to climate. However, climate variability often is large and can obscure climate change signals, so developing models that account for short-term variability will be important for detection of long-term trends. Carbon and nitrogen cycles can exert strong feedbacks on climate (positive and negative), and quantification of carbon and nitrogen fluxes and associated processes is planned as an important component of WEBB research in the future.

Complementing the hydrologic and biogeochemical data obtained from the WEBB sites since 1991 is an important priority for the program, helping put the WEBB record of environmental change in an extended historical context. There are several ways to extend the WEBB records of environmental change. The first is to make full use of the data available from other, earlier and concurrent, Federal (or State/local) agency investigations (e.g. ARS, LTER, and FS data). In addition to extending our temporal knowledge of the WEBB sites, this would also add richness to the data available. It would be most useful to have all the Federal program data for the WEBB watersheds easily accessible through the Internet, preferably from some common web interface. Secondly, dendrochronological studies could be conducted to further extend the historical records of hydrologic and biotic response to climatic effects. These studies might also provide information on historical pest infestations and other environmental changes. Similarly, lake/pond sediment cores could be obtained, dated, and analyzed to also obtain a record of environmental change at least over the last century, documenting the temporal variations in flow and sediment transport, in chemical fluxes, and in biotic abundances (e.g. pollen, diatom species, and individual counts).

Indeed, the study of climatic effects in the WEBB program could be further strengthened by increasing the monitoring of biota and biological processes in the WEBB watersheds. One avenue of future research, mentioned in the statement provided above by the WEBB site coordinators, could be to provide a better understanding of the effects and feedbacks of changing vegetative-cover distribution on evapotranspiration and water/sediment budgets, as well as on nutrient and solute cycling. Another avenue could be to examine the climatic effects of changing water/sediment budgets and nutrient cycling on aquatic invertebrate distributions and (or) on amphibian distributions. Because of their sensitivity to climate and water quality effects, and their limited ability to migrate, these populations (along with plant distributions) could be of value in assessing climatic effects and general ecosystem health in the WEBB watersheds. Monitoring and research on evapotranspiration and water availability for ecological needs are two of the key monitoring and research components (along with streamgaging and groundwater depletion) often mentioned for the National water census envisaged in the 2008 [USGS Science Strategy plan](#). Because of their potential scope, however, these

efforts to link biological, hydrological, and geochemical process research and monitoring will require increased interdisciplinary collaboration in the USGS as well as continued partnering with Federal and State agencies, university researchers, and NSF programs. The increased use of remote sensing technologies, geographic information system (GIS) modeling, habitat modeling, and watershed modeling can provide valuable help in developing a monitoring program for the WEBB watersheds.

In assessing ecosystem health, trends, and natural variability in its watersheds, the WEBB program has an opportunity to utilize and develop further the series of ecosystem indicators advanced by the Heinz Center in its recent 2008 report "[The State of the Nation's Ecosystems](#)" (Heinz Center 2008). The 108 indicators outlined by the Heinz Center can be grouped into four categories: (1) extent and pattern indicators, such as area of wetlands, length of streams, and proximity to residential areas; (2) chemical and physical characteristics, such as nutrient loads delivered, soil erosion, dissolved oxygen, and contaminant levels; (3) biological component indicators, such as threatened and endangered species, biodiversity, and percentage of non-native species; and (4) ecosystem goods and services, such as amount of timber harvested, water withdrawals, pollination services, and outdoor recreation services. The Heinz Center indicators are also grouped into a set of core national indicators and six sets of ecosystem-specific indicators (coast and oceans, farmlands, forests, freshwaters, grasslands and shrublands, and urban and suburban landscapes). The WEBB program could focus on a few of the Heinz Center indicators and might benefit from adding other indicators that may better characterize the WEBB watersheds.

The need for ecohydrology studies was described several years ago by Hunt and Wilcox (2003 a and b), who wrote in the context of coupled ecological-groundwater-surface-water processes: "There are few studies that have linked the abiotic effects that hydrologists know well to the ecological community that the public holds dear. Without understanding the ecohydrology, we will never truly answer these important societal questions" (2003 a, p. 289). The authors were referring to the need to understand ecohydrologic processes so as to better protect the biota (including humans) that depend on water to survive; they were also referring to the need to better understand

and quantify the role of biotic processes on water quality and quantity. The need to holistically integrate our understanding of biological and hydrological processes has long been at the core of USGS researcher Tom Winter's "aquatic continuum concept" (Winter 2004) and its variants (e.g., the "Wetland Continuum." Euliss et al. 2004). The need continues today, and few programs within the USGS have tried to address it.

Monitoring the seasonal timing of key ecosystem functions in the WEBB watersheds can be expected to be highly relevant in helping to understand climate effects and feedbacks on biota and water resources. The [National Phenology Network](#), a recently established, collaborative, interagency, and citizen-scientist network (Betancourt et al. 2007, 2005), could provide some help in this effort and could also benefit from some of the climate effects research and monitoring conducted in the WEBB program. In general, a better understanding of process response times and system lags in the watersheds could be developed that would allow improved adaptive management for these and other small watersheds in the face of climate and land-use change. These lags and response times occur on a wide variety of time scales, not just on seasonal scales, but often across yearly and decadal time scales and longer, affecting biologic and hydrologic responses and landscape evolution. Improved understanding and modeling of processes and response times in small research watersheds could lead to important advances in managing our larger National landscape. The small size of the WEBB watersheds uniquely lends itself to the elucidation of system processes and response times.

New and developing watershed-modeling tools, such as the USGS integrated groundwater and surface-water modeling code GSFLOW and related advances in temperature modeling of watershed biotic habitats, have great promise for helping foster an improved understanding of the biologic, hydrologic, and geochemical processes controlling water, sediment, and nutrient transport. Coupled modeling of physiochemical, hydrological, and biological processes and the development of forecasting and scenario analysis tools based on such coupling have been suggested as among the highest priorities in a recent (December 3-4, 2008) USGS-sponsored multipartner workshop that focused on the science priorities for a proposed [National Climate Change and Wildlife Science Center](#) (Haseltine and Jones 2008). The

development of modeling, geographic information system, and remote sensing tools that not only help couple a variety of biologic, hydrologic, and physicochemical processes, but also help translate process-research findings from small watershed studies into larger regional contexts and assessments will be invaluable in helping forecast the effects of climate change and changing land use. Implementing a strengthened monitoring and research plan for the WEBB watersheds in a nationally consistent framework would be a step towards this goal.

Establishing new indicators for ecosystem health in the WEBB watersheds and continuing current efforts in process research, monitoring, and modeling will contribute to a better understanding and quantification of ecosystem services (e.g., as defined in the 2005 [Millennium Ecosystem Assessment](#) synthesis report) in the watersheds. This work will help build scenario analyses to forecast the effects of climate change and land-use change on these and similar watersheds around the Nation. Most importantly, the WEBB program can help communicate to the public the importance of small watershed research programs and their relevance in preserving and managing ecosystem health and services for society.

Although some of the science directions and next steps described in our paper can be initiated with existing resources in the WEBB program, additional resources would be required to adequately implement our science vision. Close collaborations with other Federal watershed research and monitoring efforts, such as the U.S. Forest Service Experimental Forest program (e.g. [Lugo et al. 2006](#)), the Agricultural Research Service experimental watershed program (e.g. [Moran et al. 2008](#)), and the National Science Foundation LTER program (e.g. [Hobbie et al. 2003](#)), are also key to implementation of this vision.

Acknowledgments

The authors gratefully acknowledge technical reviews and discussions provided by our USGS colleagues, Martha Scholl and Richard Webb. Additionally, this article greatly benefitted from the lead author's discussions over the last year with Jill Baron (USGS) and from highly perceptive comments provided by Dorothy Tepper (USGS).

References

- Aulenbach, B.T., and R.P. Hooper. 2001. Removing climatic effects from trends in streamwater load estimates. In J.J. Warwick, ed., *Proceedings of the AWR Conference on Water Quality Monitoring and Modeling*, San Antonio, TX, 30 April–2 May 2001, pp. 47–52. American Water Resources Association.
- Aulenbach, B.T., and R.P. Hooper. 2006. The composite method: An improved method for streamwater solute load estimation. *Hydrological Processes* 20(14):3,028–3,047.
- Aulenbach, B.T., R.P. Hooper, and O.P. Bricker. 1996. Trends in precipitation and surface-water chemistry in a national network of small watersheds. *Hydrological Processes* 10(2):151–181.
- Baedecker, M.J. 2003. [Overview of the Water, Energy, Biogeochemical Budgets Program of the U.S. Geological Survey](#). In K.G. Renard, S.A. McElroy, W.J. Gburek, H.E. Canfield, and R.L. Scott, eds., *Proceedings of the First Interagency Conference on Research in the Watersheds*, Benson, AZ, 27–30 October 2003, pp. 30–35. U.S. Department of Agriculture, Agricultural Research Service.
- Baedecker, M.J., and L.C. Friedman. 2000. [Water, energy, and biogeochemical budgets: A watershed research program](#). U.S. Geological Survey Fact Sheet 165-99.
- Baron, J.S., K.R. Nydick, H.M. Rueth, B.M. Lafrancois, and A.P. Wolfe. 2005. High Elevation Ecosystem Responses to Atmospheric Deposition of Nitrogen in the Colorado Rocky Mountains, USA. In U.M. Huber, H.K.M. Bugmann, and M.A. Reasoner, eds., *Global Change and Mountain Regions: A State of Knowledge Overview*, pp. 429–436. Springer, Dordrecht, The Netherlands.
- Betancourt, J.L., M.D. Schwartz, D.D. Breshears, C.A. Brewer, G. Frazer, J.E. Gross, S.J. Mazer, B.C. Reed, and B.E. Wilson. 2007. Evolving plans for a USA national phenology network. *Eos, Transactions American Geophysical Union* 88:211.
- Betancourt, J.L., M.D. Schwartz, D.D. Breshears, D.R. Cayan, M.D. Dettinger, D.W. Inouye, E. Post, and B.C. Reed. 2005. [Implementing a U.S. national phenology network](#). *Eos, Transactions American Geophysical Union* 86:539, 542.

- Brown, E.T., R.F. Stallard, M.C. Larsen, D.L. Bourlès, G.M. Raisbeck, and F. Yiou. 1998. Determination of predevelopment denudation rates of an agricultural watershed (Cayaguás River, Puerto Rico) using in situ-produced ^{10}Be in river-borne quartz. *Earth and Planetary Sciences Letters* 160:723–728.
- Brown, E.T., R.F. Stallard, M.C. Larsen, G.M. Raisbeck, and F. Yiou. 1995. Denudation rates based on accumulation of in situ produced ^{10}Be compared with watershed mass balance results in the Luquillo Experimental Forest, Puerto Rico. *Earth and Planetary Science Letters* 129:193–202.
- Bullen, T.D., and C. Kendall. 1998. Tracing of Weathering Reactions and Flowpaths: A Multi-Isotope Approach. In C. Kendall and J.J. McDonnell, eds., *Isotopes Tracers in Catchment Hydrology*, pp. 611–646. Elsevier, New York.
- Bullen, T.D., D.P. Krabbenhoft, and C. Kendall. 1996. Kinetic and mineralogical controls on the evolution of groundwater chemistry and $^{87}\text{Sr}/^{86}\text{Sr}$ in a sandy silicate aquifer, northern Wisconsin, U.S.A. *Geochimica et Cosmochimica Acta* 60(10):1,807–1,821.
- Burns, D.A., R.P. Hooper, J.J. McDonnell, J.E. Freer, C. Kendall, and K. Beven. 1998. Base cation concentrations in subsurface flow from a forested hillslope: The role of flushing frequency. *Water Resources Research* 34(12):3,535–3,544.
- Burns, D.A., J.J. McDonnell, R.P. Hooper, N.E. Peters, J.E. Freer, C. Kendall, and K. Beven. 2001. Quantifying contributions to storm runoff through end-member mixing analysis and hydrologic measurements at the Panola Mountain Research Watershed (Georgia, USA). *Hydrological Processes* 15(10):1,903–1,924.
- Burns, D.A., N. Plummer, J.J. McDonnell, E. Busenberg, G.C. Casile, C. Kendall, R.P. Hooper, J.E. Freer, N.E. Peters, K. Beven, and P. Schlosser. 2003. The geochemical evolution of riparian groundwater in a forested piedmont catchment. *Ground Water* 41(7):913–925.
- Buss, H.L., M.A. Bruns, M.J. Schultz, J. Moore, C.F. Mathur, and S.L. Brantley. 2005. The coupling of biological iron cycling and mineral weathering during saprolite formation, Luquillo Mountains, Puerto Rico. *Geobiology* 3:247–260.
- Buss, H.L., P.B. Sak, S.M. Webb, and S.L. Brantley. 2008. Weathering of the Rio Blanco quartz diorite, Luquillo Mountains, Puerto Rico: Coupling oxidation, dissolution, and fracturing. *Geochimica et Cosmochimica Acta* 72:4,488–4,507.
- Buss, H.L., P.B. Sak, A.F. White, and S.L. Brantley. 2004. Mineral dissolution at the granite–saprolite interface. In R.B. Wanty and R.R. Seal, eds., *Water–Rock Interaction (WRI-11): Proceedings of the Eleventh International Symposium on Water–Rock Interaction*, Saratoga Springs, NY, 27 June–2 July 2004, p. 819–823. Taylor and Francis, London.
- Campbell, J.L., J.W. Hornbeck, W.H. McDowell, D.C. Buso, J.B. Shanley, and G.E. Likens. 2000. Dissolved organic nitrogen budgets for upland, forested ecosystem in New England. *Biogeochemistry* 49:123–142.
- Campbell, J.L., J.W. Hornbeck, M.J. Mitchell, M.B. Adams, M.S. Castro, C.T. Driscoll, J.S. Kahl, J.N. Kochenderfer, G.E. Likens, J.A. Lynch, P.S. Murdoch, S.J. Nelson, and J.B. Shanley. 2004. Input-output budgets of inorganic nitrogen for 24 forest watersheds in the northeastern United States: A review. *Water, Air, and Soil Pollution* 151:373–396.
- Cappellato, R., and N.E. Peters. 1995. Dry deposition and canopy leaching rates in deciduous and coniferous forests of the Georgia Piedmont: An assessment of a regression model. *Journal of Hydrology* 169:131–150.
- Carter, L.M., E. Shea, M. Hamnett, C. Anderson, G. Dolcemascolo, C. Guard, M. Taylor, T. Barnston, Y. He, M.C. Larsen, L. Loope, L. Malone, and M. Meehl. 2001. [Potential Consequences of Climate Variability and Change for the US-Affiliated Islands of the Pacific and Caribbean](#). In *The Potential Consequences of Climate Variability and Change: Foundation Report*, pp. 315–349. Report by the National Assessment Synthesis Team for the U.S. Global Change Research Program. Cambridge University Press, Cambridge.
- Chabaux, F., E. Blaes, E. Pelt, A. Dosseto, H. Buss, A. White, and S. Brantley. 2008. Rate of spheroidal weathering determined by U-series nuclides (Rio Icacos basin, Puerto Rico). *Geochimica et Cosmochimica Acta* 72:A145.
- Clark, M., D. Rupp, R. Woods, H.J. Tromp-van Meerveld, N.E. Peters, and J. Freer. 2008. Consistency between hydrological models and field observations: Linking processes at the hillslope scale to hydrological responses at the watershed scale. *Hydrological Processes* 23(2):311–319.
- Clow, D.W., and J.I. Drever. 1996. Weathering rates as a function of flow through an alpine soil. *Chemical Geology* 132:131–141.

- Clow, D.W., L. Schrott, R.M. Webb, D.H. Campbell, and M.M. Dornblaser. 2003a. Groundwater occurrence and contributions to streamflow in an alpine catchment, Colorado Front Range, USA. *Ground Water* 41(7):937–950.
- Clow, D.W., J.O. Sickman, R.G. Striegl, D.P. Krabbenhoft, J.G. Elliott, M.M. Dornblaser, D.A. Roth, and D.H. Campbell. 2003b. Changes in the chemistry of lakes and precipitation in high-elevation National Parks in the western United States, 1985–99. *Water Resources Research* 39(6):1,171.
- Doctor, D.H., C. Kendall, S.D. Sebestyen, J.B. Shanley, N. Ohte, and E.W. Boyer. 2008. Carbon isotope fractionation of dissolved inorganic carbon (DIC) due to outgassing of carbon dioxide from a headwater stream. *Hydrological Processes* 22:2,410–2,423.
- Doherty, J., and R.J. Hunt. 2009. Two statistics for evaluating parameter identifiability and error reduction. *Journal of Hydrology* 366:119–127.
- Dong, H., D.R. Peacor, and S.F. Murphy. 1998. TEM study of progressive alteration of igneous biotite to kaolinite throughout a weathered soil profile. *Geochimica et Cosmochimica Acta* 62:1,881–1,887.
- Dunne, T., and R.D. Black. 1970. Partial area contributions to storm runoff in a small New England watershed. *Water Resources Research* 6:1,296–1,311.
- Euliss, N.H., Jr., J.W. LaBaugh, L.H. Fredrickson, D.M. Mushet, K.L. Murray, G.A. Swanson, T.C. Winter, D.O. Rosenberry, and R.D. Nelson. 2004. The wetland continuum: A conceptual framework for interpreting biological studies. *Wetlands* 24(2):448–458.
- Fienen, M.F., R.J. Hunt, D.P. Krabbenhoft, and T. Clemo. In press. Obtaining parsimonious hydraulic conductivity fields using head and transport observations: A Bayesian geostatistical parameter estimation approach. *Water Resources Research*.
- Fletcher, R.C., H.L. Buss, and S.L. Brantley. 2006. A spheroidal weathering model coupling porewater chemistry to soil thickness during steady-state denudation. *Earth and Planetary Science Letters* 244(1–2):444–457.
- Freer, J., K.J. Beven, and N. Peters. 2002. Multivariate Seasonal and Sub-Period Model Rejection within the Generalised Likelihood Uncertainty Estimation Procedure. In Q. Duan, S. Sorooshian, H. Gupta, A.N. Rousseau, and R. Turcotte, eds., *Calibration of Watershed Models*, AGU Monograph—Water Science and Applications, v. 6, pp. 69–87. American Geophysical Union.
- Freer, J., J. McDonnell, K.J. Beven, D. Brammer, D.A. Burns, R.P. Hooper, and C. Kendall. 1997. Topographic controls on subsurface storm flow at the hillslope-scale for two hydrologically distinct small catchment. *Hydrological Processes* 11(9):1,347–1,352.
- Freer, J., J.J. McDonnell, K.J. Beven, N.E. Peters, D.A. Burns, R.P. Hooper, B.T. Aulenbach, and C. Kendall. 2002. The role of bedrock topography on subsurface storm flow. *Water Resources Research* 38(12):1,269.
- Gellis, A.G., R.M.T. Webb, S. McIntyre, and W.J. Wolfe. 2006. Land-use effects on erosion, sediment yields, and reservoir sedimentation: A case study in the Lago Loiza basin, Puerto Rico. *Physical Geography* 27:39–69.
- Haseltine, S., and K.B. Jones. 2008. National Climate Change and Wildlife Science Center. U.S. Geological Survey fact sheet. [online] URL: http://nccw.usgs.gov/documents/NCCWSC_factsheet.pdf. Accessed 5 June 2009.
- Heinz Center. 2008. The State of the Nation's Ecosystems 2008: Measuring the Land, Waters, and Living Resources of The United States. Island Press, Washington DC. [online] URL: <http://www.heinzctr.org/ecosystems>. Accessed 5 June 2009.
- Hobbie, J.E., S.R. Carpenter, N.B. Grimm, J.R. Gosz, and T.R. Seastedt. 2003. [The US long term ecological research program](#). *Bioscience* 53(1):21–32.
- Hooper, R.P. 2003. Diagnostic tools for mixing models of stream chemistry. *Water Resources Research* 39(3):1,055.
- Hooper, R.P., B.T. Aulenbach, D.A. Burns, J. McDonnell, J. Freer, C. Kendall, and K. Beven. 1998. Riparian control of streamwater chemistry: Implications for hydrochemical basin models. In K. Kovar, U. Tappeiner, N.E. Peters, and R.G. Craig, eds., *Hydrology, Water Resources and Ecology in Headwaters*, Proceedings of the Headwater '98 Conference, Merano, Italy, 20–23 April 1998, pp. 451–458. International Association of Hydrological Sciences Proceeding and Reports 248.
- Hooper, R.P., N. Christophersen, and N.E. Peters. 1990. Modelling streamwater chemistry as a mixture of soil-water end members: An application to the Panola

- Mountain watershed, Georgia, USA. *Journal of Hydrology* 116:321–343.
- Hornbeck, J.W., S.W. Bailey, D.C. Buso, and J.B. Shanley. 1997. Streamwater chemistry and nutrient budgets for forested watersheds in New England: Variability and management implications. *Forest Ecology and Management* 93:73–89.
- Hunt, R.J. 2003. Ground water/lake interaction modeling using the LAK3 Package for MODFLOW2000. *Ground Water* 41(2):114–118.
- Hunt, R.J., M.P. Anderson, and V.A. Kelson. 1998. Improving a complex finite-difference ground water flow model through the use of an analytic element screening model. *Ground Water* 36(6):1,011–1,017.
- Hunt, R.J., and J. Doherty. 2006. A strategy of constructing models to minimize prediction uncertainty. In *MODFLOW and More 2006: Managing Ground Water Systems*, Proceedings of the 7th International Conference of the International Ground Water Modeling Center, Golden, CO, 21–24 May 2006, pp. 56–60. Colorado School of Mines, International Ground Water Modeling Center.
- Hunt, R.J., D.T. Feinstein, C.D. Pint, and M.P. Anderson. 2005. The importance of diverse data types to calibrate a watershed model of the Trout Lake Basin, northern Wisconsin, USA. *Journal of Hydrology*, 321(1–4):286–296.
- Hunt, R.J., H.M. Haitjema, J.T. Krohelski, and D.T. Feinstein. 2003. Simulating ground water-lake interactions: Approaches and insights. *Ground Water* 41(2):227–237.
- Hunt, R.J., D.E. Prudic, J.F. Walker, and M.P. Anderson. 2008. Importance of unsaturated zone flow for simulating recharge in a humid climate. *Ground Water* 46(4):551–560.
- Hunt, R.J., R.M. Strand, and J.F. Walker. 2006. [Measuring groundwater-surface water interaction and its effect on wetland stream benthic productivity, Trout Lake watershed, northern Wisconsin, USA](#). *Journal of Hydrology* 320:370–384.
- Hunt, R.J., J.F. Walker, and J. Doherty. 2008a. Using GSFLOW to simulate climate change in a northern temperate climate. In *MODFLOW and More 2008: Ground Water and Public Policy*, Proceedings of the 9th International Conference of the International Ground Water Modeling Center, Golden, CO, 18–21 May 2008, pp. 109–113. Colorado School of Mines, International Ground Water Modeling Center.
- Hunt, R.J., J.F. Walker, and M. Strand. 2008b. Simulating sensitivity to climate change in the Trout Lake Watershed, northern Wisconsin, USA. In *Integrating Groundwater Science and Human Well-Being*, Proceedings from the IAH 36th International Congress, Toyama, Japan, 26 October–1 November 2008, 7 p. International Association of Hydrogeologists.
- Hunt, R.J., and D.A. Wilcox. 2003a. Ecohydrology: Why hydrologists should care. *Ground Water* 41(3):289.
- Hunt, R.J., and D.A. Wilcox. 2003b. Response to comment of Ecohydrology: Why hydrologists should care. *Ground Water* 41(5):562–563.
- Huntington, T.G. 1995. Carbon sequestration in an aggrading forest ecosystem. *Soil Science Society of America Journal* 59:1,459–1,467.
- Huntington, T.G. 2000. The potential for calcium depletion in forest ecosystems of southeastern United States: Review and analysis. *Global Biogeochemical Cycles* 14(2):623–638.
- Huntington, T.G., R.P. Hooper, and B.T. Aulenbach. 1994. Hydrologic processes controlling sulfate mobility in a small forested watershed. *Water Resources Research* 30(2):283–295.
- Huntington, T.G., R.P. Hooper, C.E. Johnson, B.T. Aulenbach, R. Cappellato, and A.E. Blum. 2000. Calcium depletion in a southeastern United States forest ecosystem. *Soil Science Society of America Journal* 64(5):1,845–1,858.
- Ingersoll, G.P., M.A. Mast, D.H. Campbell, D.W. Clow, L. Nanus, and J.T. Turk. 2008. Trends in snowpack chemistry and comparison to National Atmospheric Deposition Program results for the Rocky Mountains, US, 1993–2004. *Atmospheric Environment* 42(24):6,098–6,113.
- Joyce, J., and P.W. Jewell. 2003. Physical controls on methane ebullition from reservoirs and lakes. *Environmental and Engineering Geoscience* 9:167–178.
- Kendall, K.A., J.B. Shanley, and J.J. McDonnell. 1999. A hydrometric and geochemical approach to test the transmissivity feedback hypothesis during snowmelt. *Journal of Hydrology* 219:188–205.
- Krabbenhoft, D.P., C.J. Bowser, C. Kendall, and J.R. Gat. 1994. Use of Oxygen-18 and Deuterium To Assess

- the Hydrology of Groundwater-Lake Systems. In L.A. Baker, ed., *Environmental Chemistry of Lakes and Reservoirs*, pp. 67–90. American Chemical Society, Washington DC.
- Kurtz, A.C., and L.A. Derry. 2004. Tracing silicate weathering and terrestrial silica cycling with Ge/Si ratios. In R.B. Wanty and R.R.I. Seal, eds., *Water–Rock Interaction (WRI-11): Proceedings of the Eleventh International Symposium on Water–Rock Interaction*, Saratoga Springs, NY, 27 June–2 July, 2004, pp. 833–840. Taylor and Francis, London.
- Larsen, M.C. 2000. Analysis of 20th century rainfall and streamflow to characterize drought and water resources in Puerto Rico. *Physical Geography* 21:494–521.
- Larsen, M.C., P.D. Collar, and R.F. Stallard. 1993. Research plan for the investigation of water, energy, and biogeochemical budgets in the Luquillo mountains, Puerto Rico. U.S. Geological Survey Open-File Report 92-150.
- Larsen, M.C., and J.E. Parks. 1997. How wide is a road? The association of roads and mass-wasting disturbance in a forested montane environment. *Earth Surface Processes and Landforms* 22:835–848.
- Larsen, M.C., and A. Santiago-Román. 2001. Mass Wasting and Sediment Storage in a Small Montane Watershed: An Extreme Case of Anthropogenic Disturbance in the Humid Tropics. In J.M. Dorava, B.B. Palcsak, F. Fitzpatrick, and D. Montgomery, eds., *Geomorphic Processes and Riverine Habitat*, AGU Monograph—Water Science and Applications, v. 4, pp. 119–138. American Geophysical Union.
- Larsen, M.C., and A. Simon. 1993. A rainfall intensity-duration threshold for landslides in a humid-tropical environment, Puerto Rico. *Geografiska Annaler* 75A:13–23.
- Larsen, M.C., and A.J. Torres Sánchez. 1998. [The frequency and distribution of recent landslides in three montane tropical regions of Puerto Rico.](#) *Geomorphology* 24(4):309–331.
- Larsen, M.C., A.J. Torres-Sánchez, and I.M. Concepción. 1999. Slopewash, surface runoff, and fine litter transport in forest and landslide scars in humid tropical steepplands, Luquillo Experimental Forest, Puerto Rico. *Earth Surface Processes and Landforms* 24:481–506.
- Leavesley, G.H., S.L. Markstrom, R.J. Viger, and L.E. Hay. 2005. USGS Modular Modeling System (MMS)–Precipitation-Runoff Modeling System (PRMS) MMS-PRMS. In V. Singh and D. Frevert, eds., *Watershed Models*, pp. 159–177. CRC Press, Boca Raton, FL.
- Lovett, G.M., D.A. Burns, C.T. Driscoll, J.C. Jenkins, M.J. Mitchell, L. Rustad, J.B. Shanley, G.E. Likens, and R. Haeuber. 2007. Who needs environmental monitoring?. *Frontiers in Ecology and the Environment* 5(5):253–260.
- Lowry, C.S., J.F. Walker, R.J. Hunt, and M.P. Anderson. 2007. Identifying spatial variability of groundwater discharge in a wetland stream using a distributed temperature sensor. *Water Resources Research* 43: W10408. [online] URL: <http://www.agu.org/pubs/crossref/2007/2007WR006145.shtml>. Accessed 5 June 2009.
- Lugo, A.E., F.J. Swanson, O. Ramos Gonzalez, M.B. Adams, B. Palik, R.E. Thill, D.G. Brockway, C. Kern, R. Woodsmith, and R. Musselman. 2006. [Long-term research at the USDA Forest Service's Experimental Forests and Ranges.](#) *Bioscience* 56(1):39–48.
- Markstrom, S.L., R.G. Niswonger, R.S. Regan, D.E. Prudic, and P.M. Barlow. 2008. [GSFLOW—Coupled ground-water and surface-water flow model based on the integration of the Precipitation-Runoff Modeling System \(PRMS\) and the Modular Ground-Water Flow Model \(MODFLOW-2005\).](#) U.S. Geological Survey Techniques and Methods 6-D1.
- Mast, M.A., K.P. Wickland, R.G. Striegl, and D.W. Clow. 1998. Winter fluxes of CO₂ and CH₄ from subalpine soils in Rocky Mountain National Park, Colorado. *Global Biogeochemical Cycles* 12(4):607–620.
- McDonnell, J., J. Freer, R. Hooper, C. Kendall, D. Burns, K. Beven, and J. Peters. 1996. New method developed for studying flow on hillslopes. *EOS, Transactions American Geophysical Union* 77(47):465–472.
- McGlynn, B.L., J.J. McDonnell, J.B. Shanley, and C. Kendall. 1999. Riparian zone flowpath dynamics during snowmelt in a small headwater catchment. *Journal of Hydrology* 222:75–92.
- Millennium Ecosystem Assessment. 2005. [Ecosystems and Human Well-Being: Synthesis.](#) Island Press, Washington DC.

- Moran, M.S., D.P.C. Peters, M.P. McClaran, M.H. Nichols, and M.B. Adams. 2008. [Long-term data collection at USDA experimental sites for studies of ecohydrology](#). *Ecohydrology* 1:377–393.
- Murphy, S.F., S.L. Brantley, A.E. Blum, A.F. White, and H. Dong. 1998. Chemical weathering in a tropical watershed, Luquillo Mountains, Puerto Rico: II. Rate and mechanism of biotite weathering. *Geochimica et Cosmochimica Acta* 62:227–243.
- Peters, N.E. 1989. Atmospheric Deposition of Sulfur to a Granite Outcrop in the Piedmont of Georgia, U.S.A. In D.J. Delleur, ed., *Atmospheric Deposition*, pp. 173–181. International Association of Hydrological Sciences, no. 179.
- Peters, N.E. 1994. Water-quality variations in a forested piedmont catchment, Georgia, USA. *Journal of Hydrology* 156:73–90.
- Peters, N.E., J. Freer, and B.T. Aulenbach. 2003a. Hydrologic dynamics of the Panola Mountain Research Watershed, Georgia, USA. *Ground Water* 41(7):973–988.
- Peters, N.E., J. Freer, and K.J. Beven. 2003b. Modeling hydrologic responses in a small forested catchment (Panola Mountain, Georgia, USA): A comparison of the original and a new dynamic TOPMODEL. *Hydrological Processes* 17(2):345–362.
- Peters, N.E., T.P. Meyers, and B.T. Aulenbach. 2002. Status and trends in atmospheric deposition and emissions near Atlanta, Georgia, 1986–99. *Atmospheric Environment* 13(10):1,577–1,588.
- Peters, N.E., and E.B. Ratcliffe. 1998. Tracing hydrologic pathways using chloride at the Panola Mountain Research Watershed, Georgia, USA. *Water, Air and Soil Pollution* 105(1/2):263–275.
- Peters, N.E., E.B. Ratcliffe, and M. Tranter. 1998. Tracing Solute Mobility at the Panola Mountain Research Watershed, Georgia, USA: Variations in Na⁺, Cl⁻, and H₄SiO₄ Concentrations. In K. Kovar, U. Tappeiner, N.E. Peters, and R.G. Craig, eds., *Hydrology, Water Resources and Ecology in Headwaters*, pp. 483–490. International Association of Hydrological Sciences, no. 248.
- Peters N.E., J.B. Shanley, B.T. Aulenbach, R.M. Webb, D.H. Campbell, R. Hunt, M.C. Larsen, R.F. Stallard, J. Troester, and J.F. Walker. 2006. [Water and solute mass balance of five small, relatively undisturbed watersheds in the U.S.](#) *Science of the Total Environment* 358(1–3):221–242.
- Pint, C.D., R.J. Hunt, and M.P. Anderson. 2003. Flow path delineation and ground water age, Allequash Basin, Wisconsin. *Ground Water* 41(7):895–902.
- Scatena, F.N., and M.C. Larsen. 1991. Physical aspects of Hurricane Hugo in Puerto Rico. *Biotropica* 23(4A):317–323.
- Schindler, J.E., and D.P. Krabbenhoft. 1998. The hyporheic zone as a source of dissolved organic carbon and carbon gases to a temperate forested stream. *Biogeochemistry* 43:157–174.
- Scholl, M.A., W. Eugster, and R. Burkard. In press. Understanding the Role of Fog in Forest Hydrology: Stable Isotopes as Tools for Determining Input and Partitioning of Cloud Water in Montane Forests. In L.A. Bruijnzeel, F.N. Scatena, and L.S. Hamilton, eds., *Mountains in the Mist: Science for Conserving and Managing Tropical Montane Cloud Forests*. Cambridge University Press, Cambridge.
- Schulz, M.S., and A.F. White. 1999. Chemical weathering in a tropical watershed, Luquillo Mountains, Puerto Rico: III. Quartz dissolution rates. *Geochimica et Cosmochimica Acta* 63:337–350.
- Schuster, P.F., M.M. Reddy, G.R. Aiken, and J.B. Shanley. 2004. What effect does permafrost have on dissolved organic carbon transport to streams during snowmelt. In R.B. Wanty, and R.R. Seal, eds., *Water–Rock Interaction (WRI-11)*, v. 2: Proceedings of the Eleventh International Symposium on Water–Rock Interaction, Saratoga Springs, NY, 27 June–2 July 2004, pp. 1,385–1,389. Taylor and Francis, London.
- Schuster, P.F., J.B. Shanley, M. Marvin-Dipasquale, M.M. Reddy, G.R. Aiken, D.A. Roth, H.E. Taylor, D.P. Krabbenhoft, and J.F. DeWild. 2008. Mercury and organic carbon dynamics during runoff episodes from a northeastern USA watershed. *Water, Air, and Soil Pollution* 187:89–108.
- Sebestyen, S.D., E.W. Boyer, J.B. Shanley, C. Kendall, D.H. Doctor, G.R. Aiken, and N. Ohte. 2008. Sources, transformations, and hydrological processes that control stream nitrate and dissolved organic matter concentrations during snowmelt in an upland forest. *Water Resources Research* 44:W12410.
- Shanley, J.B. 1992. Sulfur retention and release in soils at Panola Mountain, Georgia. *Soil Science* 153(6):499–508.

- Shanley, J.B., K.N. Hjerdt, J.J. McDonnell, and C. Kendall. 2003. Shallow water table fluctuations in relation to soil penetration resistance. *Ground Water* 41:964–972.
- Shanley, J.B., C. Kendall, T.E. Smith, D.M. Wolock, and J.J. McDonnell. 2002. Controls on old and new water contributions to stream flow at some nested catchments in Vermont, USA. *Hydrological Processes* 16:589–609.
- Shanley, J.B., P. Krám, J. Hruska, and T.D. Bullen. 2004. [A biogeochemical comparison of two well-buffered catchments with contrasting histories of acid deposition](#). *Water, Air, and Soil Pollution: Focus* 4:325–342.
- Shanley, J.B., and N.E. Peters. 1993. Variations in aqueous sulfate concentrations at Panola Mountain, Georgia. *Journal of Hydrology* 146:361–382.
- Shanley, J.B., A. Mast, D.H. Campbell, G.R. Aiken, D.P. Krabbenhoft, R.J. Hunt, J.F. Walker, P.F. Schuster, A. Chalmers, B.T. Aulenbach, N.E. Peters, M. Marvin-DiPasquale, D.W. Clow, and M.M. Shafer. 2008. Comparison of total mercury and methylmercury cycling at five sites using the small watershed approach. *Environmental Pollution* 154(1):143–154.
- Shanley, J.B., B. Mayer, M.J. Mitchell, and S.W. Bailey. 2008. Seasonal and event variations in $\delta^{34}\text{S}$ values of stream sulfate in a Vermont forested catchment: Implications for sulfur sources and cycling. *Science of the Total Environment* 404:262–268.
- Shanley, J.B., B. Mayer, M.J. Mitchell, R.L. Michel, S.W. Bailey, and C. Kendall. 2005. Tracing sources of streamwater sulfate during snowmelt using S and O isotope ratios of sulfate and ^{35}S activity. *Biogeochemistry* 76:161–185.
- Stallard, R.F. 2001. Possible environmental factors underlying amphibian decline in eastern Puerto Rico: Analysis of U.S. Government data archives. *Conservation Biology* 15(4):943–953.
- Tromp-van Meerveld, H.J., and J.J. McDonnell. 2006a. Threshold relations in subsurface stormflow: 1. A 147-storm analysis of the Panola hillslope. *Water Resources Research* 42:W02410.
- Tromp-van Meerveld, H.J., and J.J. McDonnell. 2006b. Threshold relations in subsurface stormflow: 2. The fill and spill hypothesis. *Water Resources Research* 42:W02411.
- Tromp-van Meerveld, H.J., and J.J. McDonnell. 2006c. On the interrelations between topography, soil depth, soil moisture, transpiration rates and species distribution at the hillslope scale. *Advances in Water Resources* 29:293–310.
- Tromp-van Meerveld, H.J., N.E. Peters, J.J. McDonnell. 2007. [Effect of bedrock permeability on subsurface stormflow and the water balance of a trenched hillslope at the Panola Mountain Research Watershed, Georgia, USA](#). *Hydrological Processes* 21(6):750–769.
- Turner, B.F., R.F. Stallard, and S.L. Brantley. 2003. Investigation of in situ weathering of quartz diorite bedrock in the Río Icacos basin, Luquillo Experimental Forest, Puerto Rico. *Chemical Geology* 202:313–341.
- Walker, J.F., R.J. Hunt, T.D. Bullen, D.P. Krabbenhoft, and C. Kendall. 2003. Spatial and temporal variability of isotope and major ion chemistry in the Allequash Creek basin, northern Wisconsin. *Ground Water* 41(7):883–894.
- Walker, J.F., and D.P. Krabbenhoft. 1998. Groundwater and Surface-Water Interactions in Riparian and Lake-Dominated Systems. In J.J. McDonnell, and C. Kendall, eds., *Isotope Tracers in Catchment Hydrology*, pp. 467–488. Elsevier, Amsterdam, The Netherlands.
- Walker, J.F., D.A. Saad, and R.J. Hunt. 2007. Dynamics of CFCs in northern temperate lakes and adjacent groundwater. *Water Resources Research* 43:W04423.
- Webb, R.M.T., J.I. Linard, and M.E. Wiczorek. 2006. [The Water, Energy, and Biogeochemical Model \(WEBMOD\): A TOPMODEL application developed within the modular modeling system](#). In Proceedings of the 3rd Federal Interagency Hydrologic Modeling Conference, Reno, NV, 2–6 April 2006. Advisory Committee on Water Information, Subcommittee on Hydrology.
- Webb, R.M.T., N.J. Peters, B.T. Aulenbach, and J.B. Shanley. 2003. [Relations between hydrology and solute fluxes at the five water, energy, and biogeochemical budget \(WEBB\) watersheds of the United States Geological Survey](#). In K.G. Renard, S.A. McElroy, W.J. Gburek, H.E. Canfield, and R.L. Scott, eds., *Proceedings of the First Interagency Conference on Research in the Watersheds*, Benson, AZ, 27–30 October 2003, pp. 332–339. U.S. Department of Agriculture, Agricultural Research Service.

White, A.F., and A.E. Blum. 1995a. Effects of climate on chemical weathering in watersheds. *Geochimica et Cosmochimica Acta* 59:1,729–1,747.

White, A.F., and A.E. Blum. 1995b. Climatic Effects on Chemical Weathering in Watersheds: Applications of Mass Balance Approaches. In S.T. Trudgill, ed., *Solute Modeling in Catchment Systems*, pp. 101–131. John Wiley and Sons, New York.

White, A.F., A.E. Blum, T.D. Bullen, D.V. Vivit, M.S. Schulz, and J. Fitzpatrick. 1999. The effect of temperature on experimental and natural weathering of granitoid rocks. *Geochimica et Cosmochimica Acta* 63:3,277–3,291.

White, A.F., A.E. Blum, M.S. Schulz, D.V. Vivit, M. Larsen, and S.F. Murphy. 1998. Chemical weathering in a tropical watershed, Luquillo Mountains, Puerto Rico: I. Long-term versus short-term weathering fluxes. *Geochimica et Cosmochimica Acta* 62:209–226.

Wickland, K.P., R.G. Striegl, M.A. Mast, and D.W. Clow. 2001. Carbon gas exchange at a southern Rocky Mountain wetland, 1996–1998. *Global Biogeochemical Cycles* 15(2):321–335.

Winter, T.C. 2004. The aquatic systems continuum. American Geophysical Union, Fall Meeting 2004, abstract #H31F-01.

Zack, A., and M.C. Larsen. 1994. Island hydrology: Puerto Rico and the U.S. Virgin Islands. National Geographic Research and Exploration Water Issue, pp. 126–134.

Climate Change Adaptation Lessons from the Land of Dry Heat

Gregg Garfin, Katharine Jacobs, James Buizer

Abstract

The Arizona Water Institute, along with Arizona State University and the University of Arizona's Institute for the Study of Planet Earth, brought together local, State, tribal, and Federal water resources managers with agency and university scientists to identify adaptation and response strategies to climate change impacts on water supplies. The workshop participants identified the following issues and potential solutions:

- need for comprehensive water balance monitoring in anticipation of changes in the hydrologic cycle, including continuous observations of demand-side variables such as consumptive water use and evapotranspiration, in addition to perennial needs for improved groundwater, snow, and soil moisture observations;
- strong concerns about attrition of the U.S. Geological Survey streamflow network;
- concern about the implications of hydrologic non-stationarity for water management planning and infrastructure design, which will require evolution from standards-based approaches, e.g. using fixed "normals," to flexible risk-based approaches;
- need for enhanced decision-support products and processes, including innovative ways to visualize and compare the outcomes of alternative policies in the context of future climate variability;
- need for a greater emphasis on explanatory information to accompany climate projections

Garfin is a climatologist, Institute of the Environment, University of Arizona, 845 N. Park Ave., Ste 532, Tucson, AZ 85721. Jacobs is Senior Research Associate, Institute of the Environment, 845 N. Park Avenue, Ste 532, Tucson, AZ 85721-0158. Buizer is Executive Director for Strategic Institutional Advancement in the Office of the President, Arizona State University, Mail Code 7705, Tempe, AZ 85287-7705. Email: gmgarfin@email.arizona.edu.

and scenarios, and on the adoption of common decision-support tools within regions and sectors to enhance communication and consistency of analysis; and

- need for dendrohydrologic data to form the basis for improved understanding of past streamflow variability and sequences of low flows, and to plan for worst-case scenarios and to hedge bets when purchasing alternative supplies—managers need more reliable high-flow estimates and the ability to distinguish summer and winter reconstructed flows.

Keywords: climate change, adaptation, non-stationarity, water management, dendrohydrology

Introduction

On February 5, 2008, at Biosphere 2 in Oracle, AZ, the Arizona Water Institute, in collaboration with Arizona State University and the University of Arizona's Institute for the Study of Planet Earth, brought together key water resources managers with agency and university scientists to identify specific adaptation and response strategies to climate change impacts on water supplies. The "Workshop on Climate Change Adaptation for Water Managers: Exploring Adaptation Tools and Strategies" used an informal café-style conversation format to foster an atmosphere conducive to community building and to strengthen a "knowledge network" of practitioners and researchers. Participants discussed a wide variety of options, ultimately identifying a suite of priority strategies in areas ranging from climate change monitoring to engineering challenges. In addition, invited speakers discussed the role of conservation in addressing water supply needs. This summary provides key highlights from each of the topics that were discussed.

The participants engaged in facilitated conversations on the following topics:

- Climate prediction tools and their utility for water management;
- Strategic monitoring needs related to climate change;
- Changes in engineering practices that may be required for water, wastewater, and stormwater management, especially in the context of increased climate variability;
- Market solutions to drought, including compensated, temporary voluntary transfers from agriculture to urban uses;
- Connections between energy and water, including policy, technology, cost, and emissions considerations of alternative water and energy supplies;
- Decision support needs in the context of climate change; and
- Use of tree-ring records for understanding climate variability.

Methods

The following synthesis highlights major observations from small group sessions on each topic. The organizers and group session facilitators culled these highlights, within one week of the workshop, from their notes and notes taken by student assistants.

Results

Climate prediction tools and their utility for water management

An array of climate tools can currently be used to forecast temperature and precipitation up to a year in advance. These tools all provide probabilistic forecasts and have a range of skill that is dependent on multiple factors. Researchers observed that, with certain exceptions, there is a large gap between the climate prediction tools that water managers use and what is available.

Participants agreed that we are at the end of an era when we can use the assumption that future climate and hydrology will resemble past climate and hydrology as a foundation of water resources planning, management, and operational practices (Milly et al. 2008). This assertion, that the dynamics and statistics of the

hydroclimatic system are a moving target (i.e., non-stationary), has significant implications for water management planning and infrastructure design, as well as for the utility of the existing prediction tools. Accommodating climate non-stationarity will require an evolution from standards-based approaches (based on a historic view of “normal”) to more flexible risk-based approaches.

Research needs identified in the sessions include: How will accuracy of predictions of climate and hydrologic variability change with warming? What are the implications of climate change for groundwater availability and management? How can hydrologic forecasts be extended beyond annual volumes to provide information about seasonality, timing of peak surface water flows, and extremes? Can we develop better snowmelt/runoff models for operational purposes? Can climate predictions be linked to end-to-end systems that merge the analysis of major factors affecting local operational and (or) management decisions into a coherent framework?

Strategic monitoring

Participants strongly recommended improved monitoring of all aspects of the water balance, with particular emphasis on detailed, continuous observations of demand-side variables such as consumptive water use and evapotranspiration. Lack of adequate groundwater data to monitor changes in areas not influenced by pumping was universally cited as a high priority for strategic monitoring investments.

Monitoring of ecosystem responses and interactions between ecosystems and hydrology were assigned a high priority, especially given recent and projected ecosystem changes and their effect on evapotranspiration, runoff, and sediment transport. Participants also emphasized the need for strategic investment in monitoring in mountainous regions, especially with respect to snow climatology and hydrology, given observed and predicted changes in snow hydrology and melt dates.

Workshop participants voiced concerns about maintaining the current network of stream gages and noted the critical need to expand and improve observations of low flows. They raised strong concerns about continued retirement of gages from the network, which undermines society’s ability to monitor climate

changes, thereby increasing vulnerability to changes. Given the many large-acreage fires in Arizona during the last decade, participants expressed a need for better observations of sediment transport. Participants also noted a critical lack of water quality data in comparison with water quantity information. They noted that reliable, high quality, credible benchmark measurements are needed to discern future trends and abrupt changes.

Research needs include: better quantification of relationships between highly variable summer precipitation and recharge; improved understanding of snow hydrology, diagnostics of snowmelt, and runoff and soil moisture recharge when rain or snow events occur; and improved understanding of connections between surface water and groundwater.

Engineering for climate change

Climate change will pose a number of challenges for those who design and operate water supply, water treatment, and flood control infrastructure. Although participants felt that engineers have the tools to develop a range of adaptation options for climate change, there are limitations on fully preparing for the magnitude of anticipated changes because the risks are not well recognized and existing conventions, e.g. rule curves, limit innovation.

Workshop participants expressed strong support for more holistic and integrated planning as well as looking at a range of hard and soft approaches that consider economic and non-economic impacts and that examine direct and indirect effects of decisions. To implement some of these approaches (e.g., gray water reuse) while minimizing unintended consequences (e.g., expansion of lawn watering), the risks and trade-offs associated with various decisions must be communicated clearly to stakeholders.

Participants noted that more distributed networks of water and wastewater systems would be more reliable, sustainable, and manageable. They suggested promoting higher efficiency in water use, as well as the use of renewable alternative energy, such as solar energy. It was pointed out that the challenges of adapting existing infrastructure are different from designing new development to cope with climate change. Participants also noted that while broader, more creative engineering is essential, it must be accompanied by behavioral

changes in order to realize the full benefits of innovation.

Research needs include: development of new engineering design methods that are robust as we move into less stable climate conditions; evaluations of how these new practices can best be integrated into existing institutions; and better temporal and spatial global circulation model downscaling for use in planning for future impacts of climate change.

Market solutions to water supply shortages

Market mechanisms, such as financial incentives to transfer water from agriculture and pricing structures that encourage conservation, are frequently touted as solutions to water supply problems.

Discussion in this session focused on temporary pricing signals and programs (drought surcharges, emergency transfers of water rights) versus permanent price reform (scarcity pricing). There was concern about whether we are foreclosing opportunities by permanently retiring agricultural rights because agriculture represents a buffer of water supplies that may be purchased in emergencies.

Participants also observed that there are unintended consequences of increased pricing and (or) conservation. For example, education and conservation programs reduce water use, which leads to price hikes to maintain revenue stream and, in turn, outraged customers who feel punished for conserving. To enhance the effectiveness of price signals, utilities need to do a better job of communicating to the public the issues that cause water shortages, such as growth in demand, drought, or changes in water quality standards.

Research needs include: improved methodologies and their application to valuing non-traditional goods and services, such as ecosystem flows, and community social and employment patterns that may be affected by exporting or transferring water; also, development of tools for predicting the effects of changes in price on demand in individual service areas.

The energy–water nexus

The connection between energy and water is far more intense than is generally acknowledged. Pumping, treating, and heating water are among the largest

demands for energy in the United States, and generating energy is one of the largest uses of water. Further, many of the “new” water supply options, including desalination and importation, are very energy intensive.

Climate change puts bounds on the intensive use of energy for water management. The effects of water management decisions on energy and carbon emissions need to be considered, and we need to avoid promoting adaptation measures that exacerbate the emissions of carbon dioxide.

Participants noted that water conservation has low-cost, socially acceptable benefits in **both** water and energy terms, and when conservation benefits are evaluated from both perspectives, the cost effectiveness improves dramatically. Water reuse can also be surprisingly efficient from an energy perspective.

Water managers are not energy experts; they need partnerships with energy providers to identify opportunities to save water in generation of electricity and to save energy in pumping, treating, and delivering water. Opportunities need to be identified for water and energy managers to collaboratively exchange information on their decisionmaking processes, which would ultimately lead to joint water and energy planning.

Research needs include: assessment of the energy intensity of alternative water supplies in Arizona, using an approach developed for California but validated for applications in Arizona; quantification of the impacts of small-scale versus large-scale energy–water solutions; evaluation of new incentives and social market transformation mechanisms, given that market forces alone may not be sufficient to meet emissions and energy goals; and identification of alternative energy options, particularly solar photovoltaic, for water treatment.

Decision support

Decision support is a process that requires building mutual trust in equal parts among data experts, modelers, water managers, decisionmakers, and the public; the process and the decision tools must be transparent, flexible, and based on the best and most timely information. Participants agreed that much more decision support is needed in Arizona.

To improve decision tools, workshop participants recommended that more emphasis be placed on the policy inputs to the decisions: decisionmakers need innovative new ways to visualize and compare the outcomes of policy changes in the context of climate-induced variability. In addition, participants recommended more explanatory information (e.g. metadata, caveats regarding use) to accompany climate change projections and scenarios.

Managers attending the workshop recommended the following characteristics for useful decision support tools: simple interfaces; a high degree of interactivity; transparency of data sources, assumptions, and uncertainties; spatial and temporal scales relevant to decisions; the ability to visualize and contrast alternatives; the ability to locate decision points within a decision tree or context; and the ability to demonstrate potential policy changes with respect to historical situations.

One approach offered to improve regional water management planning is **shared vision modeling**—adopting common decision support tools within regions and sectors to enhance communication and consistency of analysis. For example, Texas uses standardized models for groundwater and surface water in all 16 of its planning regions. Some Arizona participants noted that collaborative learning by stakeholders and researchers in a shared vision context results in greater acceptance of the outcomes and an improved understanding of uncertainties in observations and estimates as well as the connections among models, observations, and system sensitivities.

Paleoclimate

Tree-ring records have a physical basis that can represent more certainty about conditions beyond those documented in gage records than do modeled or synthetic data. Therefore, managers place greater trust in tree-ring data than in model predictions. Participants noted that one of the best uses of tree-ring records is to demonstrate past climate and hydrologic variability to policy makers, boards of directors, and the public, which can pave the way to changes in operational management.

Water managers in the western United States have used tree-ring reconstructions to test current operational rules, developed using a relatively brief gage record,

against a longer record that captures more extremes. Managers have also used tree-ring reconstructions to determine, for example, the likelihood of sequences of consecutive dry or low-flow years or the duration of drought episodes (shifting their perspectives from a 3–7 yr horizon to a 20–30 yr horizon). Streamflow reconstructions have been used to estimate long-term averages, interannual and multi-decade variability, sequences of past flows, and the likelihood of joint occurrences (e.g., joint occurrence of drought in the Upper and Lower Colorado River Basins). The results of these analyses have then been applied to management decisions regarding necessary supply reserves, planning worst case scenarios, or to hedge bets when making allocations or purchasing water from alternative supplies.

The current state-of-the-art tree-ring science methods produce more reliable estimates of low flows. A key research need is to improve the accuracy of high flow estimates. Another is to overlay projected climate change effects on paleo-estimates of natural variability of flow; this kind of approach, using a trusted data source, may be useful in some scenario planning exercises. Participants also recommended research to expand and improve summer precipitation reconstructions in order to examine joint sequences of past winter and summer precipitation. Scientists see the opportunity to use tree rings to reconstruct groundwater variations and for use in parameterizing surface/groundwater models. Tree-ring data can also be used to attribute past drought episodes to certain combinations of atmospheric circulation patterns.

Conclusions

This summary is necessarily brief and lacks most of the richness and detail of the conversations at this workshop. Comments by workshop participants provide examples specific to water management concerns. However, their comments, concerns, and insights resonate with broader assessments of adaptations necessary to address watershed and ecosystem management under climate change, such as the recent paper by Dettinger and Culberson (2008). A key conclusion of these authors that validates concerns of Workshop on Climate Change Adaptation for Water Managers participants is that climate change must be considered in the context of ongoing climate variability and an array of human alterations to watersheds, landscapes, and water supplies, such as population

growth, groundwater pumping, land use changes, invasive species, and many more.

See <http://azwaterinstitute.org/index.html> for more information about the workshop and its outcomes.

Acknowledgments

The authors gratefully acknowledge workshop funding by the Harvard University Knowledge Systems for Sustainable Development Project, the Water Resources Research Center at the University of Arizona, and the U.S. Bureau of Reclamation. We would like to thank Biosphere II director Travis Huxman and his staff for their support. We thank Rosalind Bark, Lana Jones, Kiyomi Moreno, Aleix Serrat-Capdevilla, Matt Switanek, and Will Veatch for taking extensive notes. Bonnie Colby, George Frisvold, Gregg Garfin, Holly Hartmann, Kathy Jacobs, Paul Kirshen, Edwin Maurer, Dave Meko, Kelly Redmond, Chris Scott, Peter Troch, Robert Wilkinson, Andy Wood, Connie Woodhouse, and David Yates facilitated discussion and contributed to this summary.

References

- Dettinger, M.D., and S. Culberson. 2008. Internalizing climate change: Scientific resource management and the climate change challenges. *San Francisco Estuary and Watershed Science* 6(2). [online] URL: <http://repositories.cdlib.org/jmie/sfews/vol6/iss2/art5>. Accessed 5 June 2008.
- Milly, P.C.D., J. Betancourt, M. Falkenmark, R.M. Hirsch, Z.W. Kundzewicz, D.P. Lettenmaier, and R.J. Stouffer. 2008. Stationarity is dead: Whither water management? *Science* 319:573–574.

An Ecosystem Services Framework for Multidisciplinary Research in the Colorado River Headwaters

D.J. Semmens, J.S. Briggs, D.A. Martin

Abstract

A rapidly spreading Mountain Pine Beetle epidemic is killing lodgepole pine forest in the Rocky Mountains, causing landscape change on a massive scale. Approximately 1.5 million acres of lodgepole-dominated forest is already dead or dying in Colorado, the infestation is still spreading rapidly, and it is expected that in excess of 90 percent of all lodgepole forest will ultimately be killed. Drought conditions combined with dramatically reduced foliar moisture content due to stress or mortality from Mountain Pine Beetle have combined to elevate the probability of large fires throughout the Colorado River headwaters. Large numbers of homes in the wildland-urban interface, an extensive water supply infrastructure, and a local economy driven largely by recreational tourism make the potential costs associated with such a fire very large. Any assessment of fire risk for strategic planning of pre-fire management actions must consider these and a host of other important socioeconomic benefits derived from the Rocky Mountain Lodgepole Pine Forest ecosystem. This paper presents a plan to focus U.S. Geological Survey (USGS) multidisciplinary fire/beetle-related research in the Colorado River headwaters within a framework that integrates a wide variety of discipline-specific research to assess and value the full range of ecosystem services provided by the Rocky Mountain Lodgepole Pine Forest ecosystem. Baseline, unburned conditions will be compared with a hypothetical, fully burned scenario to (a) identify where services would be most severely

Semmens and Briggs are research scientists with the U.S. Geological Survey, Rocky Mountain Geographic Science Center, P.O. Box 25046, DFC MS-516, Denver, CO 80225. Martin is a research scientist with the U.S. Geological Survey, Water Resources Division, 3215 Marine St, Suite E-127, Boulder, CO 80303. Email: dsemmens@usgs.gov.

impacted, and (b) quantify potential economic losses. Collaboration with the U.S. Forest Service will further yield a distributed model of fire probability that can be used in combination with the ecosystem service valuation to develop comprehensive, distributed maps of fire risk in the Upper Colorado River Basin. These maps will be intended for use by stakeholders as a strategic planning tool for pre-fire management activities and can be updated and improved adaptively on an annual basis as tree mortality, climatic conditions, and management actions unfold.

Keywords: research integration, mountain pine beetle, wildfire, risk assessment, ecosystems

Introduction

Ecosystem services are concisely defined as the benefits people obtain from ecosystems: “*provisioning services* such as food, water, timber, and fiber; *regulating services* that affect climate, floods, disease, wastes, and water quality; *cultural services* that provide recreational, aesthetic, and spiritual benefits; and *supporting services* such as soil formation, photosynthesis, and nutrient cycling” (Millennium Ecosystem Assessment 2005, p. v).

The goods and services provided by the ecosystems of the Upper Colorado River Basin are of national significance. Water provided from Grand and Summit Counties alone totals approximately 1.1 maf (million acre-feet) per yr on average to 16 U.S. and 2 Mexican states. The same area also boasts a wide array of cultural services that generate significant revenue for local businesses and the State: eight world-class ski areas, whitewater rafting, hunting, fishing, mountain biking, camping, and general outdoor recreation. These and other services are dependent in some measure on the forest, and a comprehensive effort to quantify and value them is particularly important in the face of large-scale changes to the forest ecosystems.

The Colorado Headwaters Project (CHP) plans described in this paper employ the assessment of ecosystem services and their value for the purpose of wildfire risk assessment and the prioritization of mitigation efforts. To reconcile landscape and service conservation with aggressive risk-management actions, it is essential that the ecological, sociocultural, and economic values of a landscape be fully accounted for in forest management planning prior to potential fires. The CHP builds upon a preexisting, multidisciplinary U.S. Geological Survey (USGS) Fire Science Demonstration Project that is addressing the numerous hazards associated with the Mountain Pine Beetle (MPB) epidemic and potential for large-scale fire, with the goal of mitigating effects on people, property, and natural resources in the Colorado River headwater forests. The CHP provides a framework for integrating discipline-specific research contributions into a comprehensive analysis of the risk posed by fire. It will further result in the development of a common, actionable set of products (maps of fire risk) that can be delivered to Federal, State, and local managers to assist with pre-fire decision support. These products can be updated adaptively on an annual basis prior to each fire season.

The U.S. Department of Agriculture–Forest Service (USFS) has, out of necessity, often prioritized tactical operations over long-term strategic planning in their approach to fire readiness. Rapid Assessment of Values At Risk (RAVAR) and other Wildland Fire Decision Support System (WFDSS, <http://wfdss.usgs.gov/>) tools are designed to assist fire managers and agency administrators in making decisions regarding responses to active wildland fires; they are not specifically designed to assist with pre-fire management planning. In addition, the WFDSS tools focus on structures and infrastructure in assessing values at risk. Although they can account for threatened and endangered species habitat and cultural sites, broader ecosystem services and their associated values are not presently considered. Recently, however, the USFS has proposed using the concept of ecosystem services as a framework for (1) describing the many benefits provided by public and private forests, (2) evaluating the effects of policy and management decisions involving public and private forest lands, and (3) advocating the use of economic and market-based incentives to protect private forest lands from development (Kline 2007). Forest Service research is therefore closely aligned with the objectives of the CHP, and we anticipate that many collaborative

opportunities for adaptive management will arise as we develop our study.

Study Area

The Colorado River originates in the mountains of central Colorado within the Southern Rocky Mountain physiographic province. Ecosystems within the upper basin are closely associated with elevation and range from alpine tundra at the highest elevations down through spruce-fir, lodgepole pine, aspen, and sagebrush shrubland.

The original USGS research focus on Grand County, CO, combined with the need to model hydrologic services, led us to adopt a watershed boundary for the project whose outlet is located on the county line. The watershed encompasses almost all of Grand County, as well as the adjacent Summit County to the south; both county boundaries are defined primarily along the drainage divides (Figure 1).

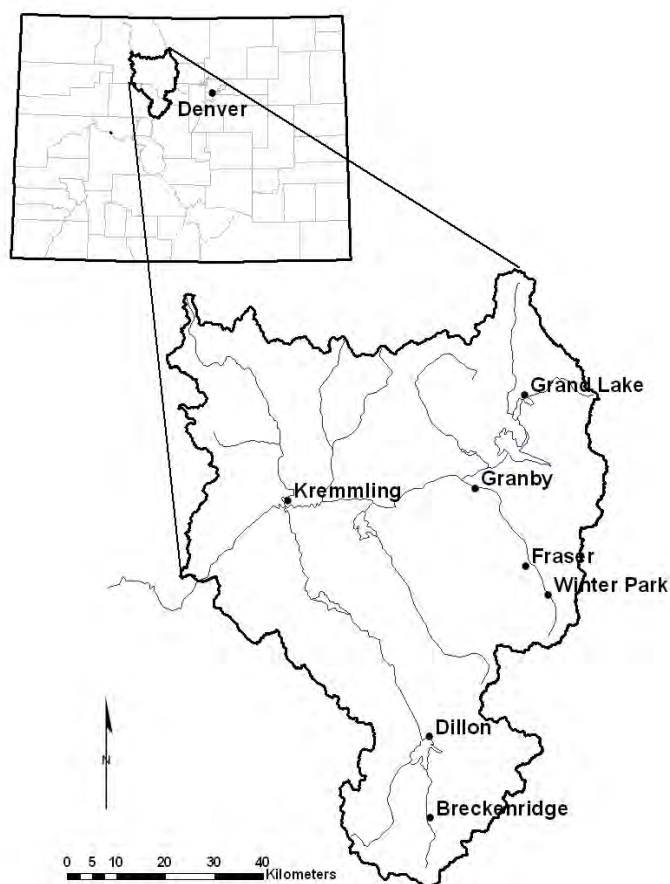

Figure 1. Map showing the preliminary boundary for the Colorado River headwaters study area.

Methods

The CHP will comprise five main steps: (1) service identification, (2) scenario development, (3) ecosystem goods and services assessment, (4) valuation, and (5) integrated risk assessment. Each of these is described separately below.

Service identification

An ecosystem functions analysis approach similar to that described by de Groot (2006) will be used in combination with conceptual modeling of ecosystem components and interactions to translate the complex ecology (structures and processes) into a more limited number of ecosystem functions and their associated goods and services. In this context, ecosystem functions are defined as the capacity of natural processes and components to provide goods and services that satisfy human needs (de Groot 2006). This process is expected to identify the most influential or valuable services provided by the lodgepole forest ecosystem, as well as important service transfers to other ecosystems.

Scenario development

Scenario development is a critical component of ecosystem service analyses because it provides the means to explore the consequences of alternative actions or conditions. Given the regional emphasis on Mountain Pine Beetle and the effects of fire, scenario development will likewise reflect the conditions these stressors will affect. We will not address mitigation of these conditions through the incorporation of forest management scenarios. However, concurrent USFS research in the Upper Colorado River Basin will focus on the analysis of management/harvest alternatives, their cost, and ultimate impacts in terms of selected ecosystem services. It is hoped that further collaboration with the USFS will ultimately lead to a synthesis of the two projects, which would permit a cost-benefit analysis of management alternatives.

Due to the stochastic nature of fire initiation, it is impossible to forecast specific fires and thus inappropriate to consider specific fire scenarios. For strategic planning at large spatial scales it will be more productive to explore the consequences of fire throughout the project area given the fuel loading conditions associated with different extents and stages of tree mortality from Mountain Pine Beetle. Scenario

development will thus focus on the extent of beetle-killed trees and the likely severity of potential fire. A total of 5 scenarios will be developed: (1) pre-MPB; (2) current extent of the MPB epidemic, no fire; (3) future 100 percent tree mortality, no fire; (4) current MPB, fully burned; and (5) future 100 percent tree mortality, fully burned.

Tree mortality

After trees are attacked by beetles they progress through several stages of physiological senescence: (1) needles fade from green to red as they lose moisture; (2) needles drop from the trees, but fine twigs remain; (3) all twigs drop from the trees; and (4) trees fall. Each stage is characterized by distinct fuel loads and thus distinct fire behavior. Three land-cover scenarios will be developed to represent the different stages of tree mortality. The first will be a pre-epidemic scenario representing conditions in the early 1990s that will serve as a baseline for evaluating effects associated with tree mortality alone. The second will represent current conditions and be derived from a map of the stage and extent of beetle-killed trees throughout the basin that is currently under development. The third will represent the maximum potential extent of beetle-killed trees—100 percent lodgepole mortality. This last scenario will be a simple projection from current conditions.

Fire

The development of fire scenarios that are meaningful for landscape-scale risk assessment requires the evaluation of both the likelihood of fire occurring at any given point and the probable severity of that fire should it occur. This requires a two-step process: fire probability modeling followed by an assessment of first-order fire effects to estimate severity. The former will serve as an input to the risk assessment, and the latter will represent the fire scenarios to be assessed in terms of their impact on ecosystem services. These are described further below.

Assessing the probability of fire at any given point in the landscape is a necessary component of being able to define risk. The Fire-Climate-Society (FCS-1; Moorehouse et al. 2006) model, for example, has combined five map layers, or indices, to define fire probability on a relative scale according to user-defined importance: fuel moisture stress index, fire return interval departure, large fire ignition probability, lightning probability, and human factors of fire ignition. In the present analysis, a collaborative

arrangement with the USFS Fire Modeling Institute (FMI) will permit the estimation of fire probability using the Fire Behavior Simulation Model (FSIM), a new research model that accounts for ignition probability and weather conditions based on historical observations. FSIM runs thousands of simulations for potential ignitions across the basin under a range of historic weather conditions and reports the frequency with which each cell burns as a proxy for probability. As such, the resulting fire probability is still defined on a relative scale, but the process-based fire modeling will remove the subjective importance of fire indices. USGS-USFS joint field surveys are being conducted during the summer and fall of 2008 to establish the fuels information needed to run FSIM for forests with varying degrees and stages of beetle-induced tree mortality.

Another important output of FSIM is the intensity (temperature) with which each grid cell burns, which is averaged for all simulated fires in each cell. This will be used as the basis for creating the fully burned scenarios associated with each beetle-kill scenario. These burn-intensity maps will be input to a new GIS-based version of the First Order Fire Effects Model (FOFEM). FOFEM predicts tree mortality, fuel consumption, smoke production, and soil heating caused by forest fires, and the resulting maps of fire effects can be input to ecosystem assessment models (e.g., watershed and biogeochemical cycling models). FOFEM output will thus represent the base data layers associated with fully burned scenarios. These will be generated for two of the beetle-kill scenarios—current conditions and maximum potential extent.

Goods and services assessment

The ultimate goal of assessing ecosystem services in the CHP will be to identify the areas characterized by the greatest diversity and magnitude of services. Assessments will focus on quantifying services derived from local forest ecosystems, as well as identifying where the fate of local ecosystems affects the services rendered from others. This goal draws an important distinction between services within the area of interest and those elsewhere that are affected by processes and conditions that originate in the area of interest. The study will not consider the local effects, direct or indirect, of processes or conditions beyond the study area.

The general methodology for assessing ecosystem services will involve a combination of process and landscape modeling approaches. Results of USGS studies associated with the Fire Science Demonstration Project will be directly employed in this process. These studies include:

- Hydrology—Carbon and nitrogen from dying/dead forest runoff; post-fire sediment/chemical impacts from ash and debris flows; basin-scale water-yield modeling
- Geology—Site-specific post-fire landslide hazards
- Biology—Impacts to aquatic habitat and fish population dynamics; sociocultural services assessment
- Geography—Mapping/monitoring the progression of tree mortality from Mountain Pine Beetle with remote sensing

Applying this research on a landscape scale will involve a combination of regression modeling (observations used to develop a model that can be applied across the basin) where sufficient data exist, and process modeling (observations used for model calibration) where observations can be used to define empirical response relationships. The work on landslide/debris flow and associated chemical component is already designed to be applied at the landscape scale; it provides information that cannot be derived from process models designed to be applied at this spatial scale.

Selected services can be assessed on a unit-area basis (grid cell), including food/fiber/fuel and pollination provisioning, biogeochemical cycling (including nitrogen and carbon), and nonmarket services such as wildlife habitat and cultural amenities. The remaining services, namely water quality/quantity and flow regulation, require process modeling to evaluate their accumulation within hydrologic units and translation downstream. Most basin-scale hydrologic models are quasi-distributed, subdividing basins into hydrologic units (subwatersheds) for which outputs are reported.

The relatively simple representation of rivers and streams within basin-scale hydrologic models should be sufficient for the purposes of a regional assessment in the Upper Colorado River Basin. In other areas characterized by extensive riparian forest, levies, and (or) floodplain agriculture, a more detailed hydraulic model of flow, sediment transport, and water quality might be required. The main concern in the Upper

Colorado River Basin, however, is the quantity and quality of water in reservoir storage. The latter can be addressed using a variety of water quality and hydrodynamic models.

Valuation

Once services have been assessed, the determination of service values (in terms of \$/area) will require compiling information from a wide range of sources, including published literature, market sources, and stakeholder surveys. Previous work by Costanza et al. (1997) and de Groot et al. (2002) has identified the most common valuation methods for ecosystem goods and services. Provisioning services are most commonly valued through direct market pricing and factor income methods, with the latter being applied when ecosystem services enhance incomes. Regulating services are mainly valued by indirect market valuation techniques, notably avoided cost associated with maintaining an ecosystem service and replacement cost of artificially providing a service. Cultural services are valued by means of hedonic pricing (e.g., increased property value with proximity to services), contingent valuation (e.g., social surveys of willingness to pay), and market pricing (e.g., recreation fees and tourism revenues).

Where previously published valuation information is available and appropriate, spatially explicit value transfer will be employed to estimate service values for which no primary data are available. Value transfer, also known as benefit transfer, estimates economic values by applying existing benefit estimates from studies already completed for a similar location and (or) context. Although little work has been conducted on the spatial dimension of economic valuation, a recent paper by Troy and Wilson (2006) outlines a generalized process for mapping ecosystem service values through benefit transfer. This process combines service assessment and valuation into one step by assigning fixed service values directly to a customized, project-specific land-cover typology. As such, it will only be applied for services that cannot be quantified directly via modeling or primary research. Where services can be quantified and published service values are linked directly to quantified services, the spatial benefit transfer process will be more direct. When neither primary data nor suitable published values are available to assign service values, the service will be ignored in the final cumulative value estimation process.

Structure and infrastructure (i.e., home and power line) values will be incorporated into the assessment to permit the comparison of risk assessments conducted with and without the inclusion of broader ecosystem service values. A similar study in California, commissioned by the Bureau of Land Management, used this approach to demonstrate that accounting for both market and nonmarket ecosystem services in cost-benefit analyses of forest treatments prior to fire would yield a net economic benefit in the two counties they examined (Ganz et al. 2007). In one of the two counties, including nonmarket goods and services in the analysis revealed the net economic benefit of pre-fire treatment, thus justifying treatments for the protection of additional structures.

All valuation work will be completed for both fully burned and unburned scenarios to permit the assessment of cost due to lost services that is associated with fire. This assessment of cost difference (consequence) is an important component of the risk assessment described in the next section.

Given the proposed assessment methodology, service values, although consistent in terms of scale (\$/area), will be based on a variety of spatial assessment units: grid cells, subwatersheds, ecosystem units, census tracts, and potentially other political or management units. These layers will be combined additively in a GIS to evaluate cumulative service values across the landscape. This will be accomplished by taking the union of all polygonal assessment units and then summarizing gridded results within each resulting polygon. These polygons will thus be the ultimate reporting unit for cumulative service value.

Integrated risk assessment

Fire probability and ecosystem service values will be brought together to develop basin-wide maps of fire risk that can be used to prioritize treatment areas. Fire risk will be determined for each reporting unit (polygon) via the following simple equation:

$$risk = probability \times \Sigma(consequences) \quad (1)$$

In this case the consequences are defined as the lost service value associated with fire, which can be estimated as the difference in total service value between baseline, unburned scenarios, and complete burn scenarios (Figure 2). As described previously, the fire probabilities will be relative (ordinal scale) rather

than quantitative (ratio scale). This will render it impossible to assign quantitative risk values, but for the purpose of targeting treatment areas the results will be very useful.

Fire risk will be computed using both the established RAVAR approach (i.e., including only the value of structures and infrastructure) and with the addition of ecosystem service values. This combination will facilitate comparison between the two risk assessment methodologies and illustrate exactly how the inclusion of broader ecosystem services changes risk calculations and, in turn, management priorities.

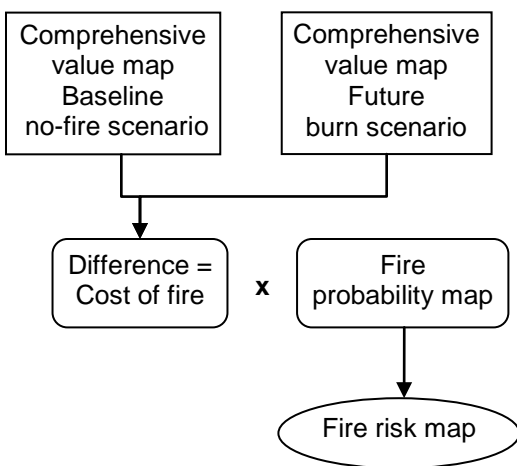

Figure 2. Flow diagram illustrating the risk assessment mapping process.

Conclusions

The assessment of ecosystem services provides a useful framework for integrating multidisciplinary research results into a format that is more readily applied by stakeholders and managers for planning and decision support. This paper outlines a plan to combine cumulative service values with modeled fire probability to evaluate fire risk on a landscape scale. Principal data outputs from this project will be maps of fire risk that can be directly employed for management planning by stakeholders to ensure that environmental and economic impacts to communities are minimized.

Acknowledgments

The authors would like to thank James Diffendorfer and Laura Norman for their thoughtful reviews of this paper.

References

- Costanza, R., R. d'Arge, R.S. de Groot, S. Farber, M. Grasso, B. Hannon, K. Limburg, S. Naeem, R.V. O'Neill, J. Paruelo, R.G. Raskin, P. Sutton, and M. van den Belt. 1997. The value of the world's ecosystem services and natural capital. *Nature* 387: 253–260.
- de Groot, R. 2006. Function-analysis and valuation as a tool to assess land use conflicts in planning for sustainable, multi-functional landscapes. *Landscape and Urban Planning* 75:175–186.
- de Groot, R.S., M. Wilson, and R. Boumans. 2002. A typology for the description, classification and valuation of ecosystem functions. *Ecological Economics* 41:393–408.
- Ganz, D.J., D.S. Saah, M.A. Wilson, and A. Toy. 2007. Efficacy of the California Bureau of Land Management Community Assistance and Hazardous Fuels Programs. In B.W. Butler and W. Cook, comps., *The Fire Environment: Innovations, Management, and Policy*. Destin, FL, 26–30 March 2007, pp. 585–606. U.S. Department of Agriculture, Forest Service, Rocky Mountain Research Station, Proceedings RMRS-P-46CD. [CD-ROM].
- Kline, J.D. 2007. Defining an economics research program to describe and evaluate ecosystem services. U.S. Department of Agriculture, Forest Service, Pacific Northwest Research Station, General Technical Report PNW-GTR-700.
- Millennium Ecosystem Assessment. 2005. *Ecosystems and Human Well-being: Synthesis*. Island Press, Washington DC.
- Moorehouse, B.J., G. Garfin, T. Brown, and T.W. Swetnam. 2006. Integrating fire, climate, and societal factors into decision support for strategic planning in wildland fire management. In C. Aguirre-Bravo, P.J. Pellicane, D.P. Burns, and S. Draggan, eds., *Monitoring Science and Technology Symposium: Unifying Knowledge for Sustainability in the Western Hemisphere*, Fort Collins, CO, 20–24 September 2004, pp. 699–705. U.S. Department of Agriculture, Forest Service, Rocky Mountain Research Station, Proceedings RMRS-P-42 CD.
- Troy, A., and M.A. Wilson. 2006. Mapping ecosystem services: Practical challenges and opportunities in linking GIS and value transfer. *Ecological Economics* 60:2, 435–449.

Engaging Stakeholders for Adaptive Management Using Structured Decision Analysis

Elise R. Irwin, Kathryn D. Mickett Kennedy

Abstract

Adaptive management is different from other types of management in that it includes all stakeholders (versus only policy makers) in the process, uses resource optimization techniques to evaluate competing objectives, and recognizes and attempts to reduce uncertainty inherent in natural resource systems. Management actions are negotiated by stakeholders, monitored results are compared to predictions of how the system should respond, and management strategies are adjusted in a “monitor-compare-adjust” iterative routine. Many adaptive management projects fail because of the lack of stakeholder identification, engagement, and continued involvement. Primary reasons for this vary but are usually related to either stakeholders not having ownership (or representation) in decision processes or disenfranchisement of stakeholders after adaptive management begins. We present an example in which stakeholders participated fully in adaptive management of a southeastern regulated river. Structured decision analysis was used to define management objectives and stakeholder values and to determine initial flow prescriptions. The process was transparent, and the visual nature of the modeling software allowed stakeholders to see how their interests and values were represented in the decision process. The development of a stakeholder governance structure and communication mechanism has been critical to the success of the project.

Keywords: stakeholders, structured decision-making, adaptive management, regulated rivers, socioecological systems

Irwin is the Assistant Unit Leader for Aquatic Resources, U.S. Geological Survey, Alabama Cooperative Fish and Wildlife Research Unit, Auburn University, AL 36849. Kennedy is a research associate also at the Alabama Cooperative Fish and Wildlife Research Unit. Email: eirwin@usgs.gov; mickekd@auburn.edu.

Introduction

Riverine systems in the Southeast are highly fragmented and managed for hydropower, navigation, flood control, and recreational needs (Irwin and Freeman 2002, Richter and Thomas 2007). These multiple-use systems require innovative approaches for management of both natural and water resources for societal needs (Irwin and Freeman 2002, Poff et al. 2003). Adaptive management is being used as a framework for managing complex riverine systems where (1) management goals conflict and (2) system uncertainty is great. Adaptive management is different from other types of management because it includes all stakeholders in the process, uses resource optimization techniques by incorporating competing objectives, and recognizes and focuses on the reduction of uncertainty inherent in natural resource systems by attempting to reduce it via knowledge acquisition (Walters 1986, Williams et al. 2007). Stakeholders negotiate a starting point for management actions, effects of management are monitored and compared with predicted results, management strategies are adjusted, and the process continues iteratively through the “monitor-compare-adjust” routine. We are actively involved in adaptive management of a southeastern regulated river. In this paper we describe the method by which we involved stakeholders in the framework by engaging them in a structured decision-making process.

Methods

The study system is the Tallapoosa River below R.L. Harris Dam in the Piedmont region of east-central Alabama (Figure 1) (Irwin and Freeman 2002). Management issues in the study reach below Harris Dam revolve around the effects of the hydropower operation on values associated with the general health of the Tallapoosa River ecosystem. In addition, power production and economic development potential in the area are management concerns and valued uses. For a

full description of the study site and management concerns, see Irwin and Freeman (2002).

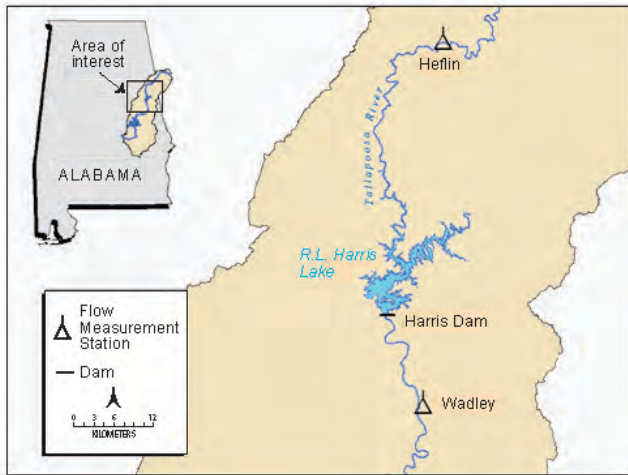

Figure 1. Location of R.L. Harris Dam on the Tallapoosa River, AL, and two USGS gages (Heflin and Wadley) are used to determine specific discharges for flow management.

We conducted a workshop in 2005 to incorporate stakeholder values and objectives into a structured decision-making model. Participants engaged in an open discussion for building consensus on management objectives and values. Presentations by experts in adaptive management of natural resources were followed by a professionally facilitated forum. We used professional facilitators to gather information from the stakeholders in an electronic format (Groupware Systems Software). Suggested objectives were judged in an electronic poll by one representative from 23 participating stakeholder groups. Fundamental objectives were developed and discussed by stakeholders; it was agreed that they were complete and representative of all involved parties. It was also agreed that the framework of adaptive management would be adopted for future discussions and management decisions. In addition, the stakeholders developed a governance structure (the R.L. Harris Stakeholders Board) to assist in future decision-making.

Objectives were used in the development of a decision support model to assist stakeholders in defining the first flow prescription in the adaptive management process. Bayesian belief network (BBN; Marcot et al. 2006) software (Netica 3.19; Norsys Software Corp. 2008) was used to develop a structured decision model.

Results

Stakeholders identified ten fundamental objectives that became the basis for the structured decision model (Table 1). Many objectives were conflicting (e.g., maximizing reservoir water levels and provision of river boating opportunities).

Table 1. Fundamental objectives identified by stakeholders via a facilitated polling process.

Fundamental objective
Maximize economic development
Maximize diversity/abundance of native fauna/flora
Minimize bank erosion downstream from Harris
Maximize water levels in the reservoir
Maximize reservoir recreation opportunities
Maximize river boating and angling opportunities
Minimize total revenues to the power utility
Maximize power utility operation flexibility
Minimize river fragmentation
Minimize consumptive use

Management options (decisions) were also identified by stakeholders and were incorporated into the BBN. The BBN incorporated 3 main decisions, 11 uncertainty nodes (stakeholder objectives), and 5 stakeholder value nodes (Figure 2). The conditional probability tables associated with each uncertainty node and decision were populated with empirical data and information from expert opinion (Kennedy et al. 2006).

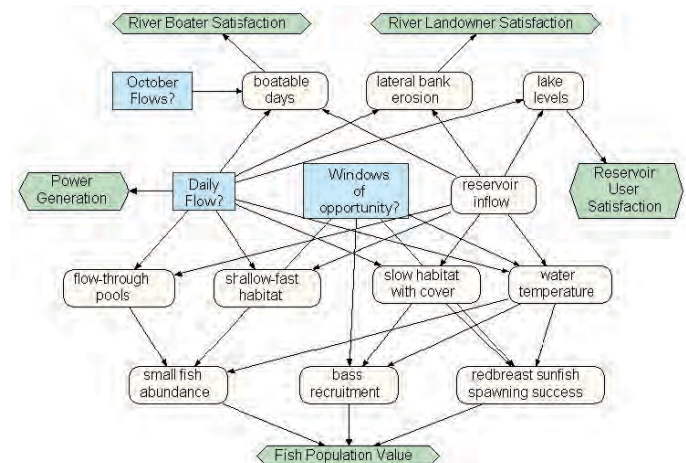

Figure 2. Influence diagram with relational arrows linking nodes included in the Bayesian Belief Network. Three decision nodes (blue boxes), 11 uncertainty nodes (white boxes), and 5 stakeholder value nodes (green hexagons) were included in the model.

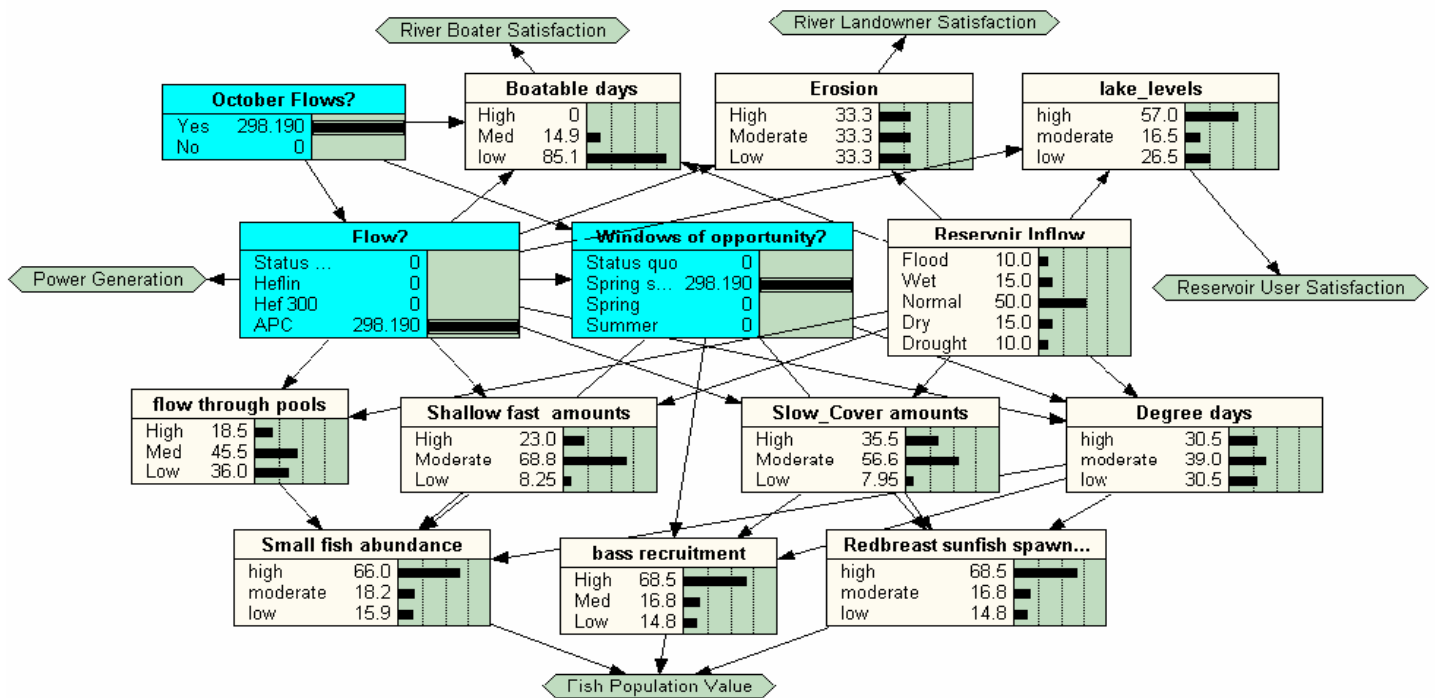

Figure 3. Bayesian Belief Network (BBN) used for structured decision-making regarding flow management below R.L. Harris Dam on the Tallapoosa River, Alabama. The decision model identified initial flow prescriptions that included pulse flows matched to the unregulated river upstream, provision of spawning periods for fish, and provision of boating flows in October. The visual nature of the BBN allowed for stakeholders to understand how the system functioned.

Management decisions were related to daily discharge (volume passed) at the dam, provision of spawning conditions (timing), and provision of October boating flows to mitigate the usual low flows in this month. Optimization was used to determine the management decision that maximized stakeholder values (Figure 3). The initial flow prescription was determined and consisted of pulse discharge from the dam that mimicked the hydrology of an upstream USGS gage in the unregulated Tallapoosa River (Heflin, Figure 1), periods of decreased power generation for fish spawning, and provision of suitable river flows for boating in October. More information regarding the specifics of the BBN can be found in Kennedy et al. (2006).

Conclusions

Quality decision making for resource allocation in complex, multi-use systems depends upon the inclusion of all individuals and groups with an investment in the system. Inclusion of a diverse group of stakeholders as active decision making participants leads to higher-quality management decisions in most cases (Beirle

2002). In addition, stakeholder involvement in decision making increases public education and fosters positive interactions among stakeholders with conflicting interests.

While stakeholders hold a vital role in management decision-making, the literature also suggests that group decision-making is least successful when it is unaided. Rather, groups of people—whether lay people, experts, or both—are most successful at making complex decisions within a structured decision process (Slovic et al. 1977, McDaniels et al. 1999, Beirle 2002). Bayesian network-based decision analysis tools are capable of providing this structure by linking all measurable variables, valued objectives, and sources of uncertainty within a visual framework supported by conditional probabilities based on empirical data and expert opinion (Netica Software Corp. 2008). Through evaluation of these inputs, stakeholders and decision makers may examine the expected effects of different management scenarios and potential system impacts (e.g., climate change, population growth) (Clemen 1996, Peterson and Evans 2003, Kennedy et al. 2006). The use of such a tool has been a key factor in

successfully engaging the stakeholder group involved with developing management strategies in the middle Tallapoosa River below R.L. Harris Dam (www.rivermanagement.org; Kennedy et al. 2006).

Ongoing successful adaptive management in the Tallapoosa River has also been attributed to continued involvement of stakeholders through their governance structure, commitment to long-term monitoring, and assessment for adjustment of future management regimes. Involvement of stakeholders in conflict resolution is critical to progress in management and evaluation of management. The use of a visual structured decision model that allowed for stakeholder input and optimization of values associated with various decisions was also critical in the process. We have been monitoring the system for 4 years and often stakeholders are involved in the collection of field data. In addition, the stakeholders have exhibited patience relative to reporting of results; updates can be viewed on the website www.rivermanagement.org. Our evaluation of management will ensue in 2009 and our hope is to begin another 5-yr assessment with continued stakeholder involvement and support.

Acknowledgments

The authors would like to thank the many stakeholders that contributed to this project. They are listed at www.rivermanagement.org. The project would not have been successful without the involvement of our facilitators, Vern Herr and Brett Boston; many hats off to them. The project was funded by the U.S. Geological Survey as a U.S. Fish and Wildlife Service Science Support Partnership Program Project (FWS SSPP # 02-R4-08) and administered through Alabama CFWRU RWO 86. The Alabama Power Company also provided funding for portions of the workshop and for facilitation of board meetings. The Alabama CFWRU is sponsored by the USGS; the Alabama Agricultural Experiment Station, Auburn University; the Alabama Department of Conservation and Natural Resources, Division of Wildlife and Freshwater Fisheries; the Wildlife Management Institute; and the USFWS.

References

Beierle, T.C. 2002. The quality of stakeholder-based decisions. *Risk Analysis* 22:739–749.

Clemen, R.T. 1996. *Making Hard Decisions: An Introduction to Decision Analysis*. Duxbury Press, Pacific Grove, CA.

Irwin, E.R., and M.C. Freeman. 2002. Proposal for adaptive management to conserve biotic integrity in a regulated segment of the Tallapoosa River, Alabama, U.S.A. *Conservation Biology* 16:1,212–1,222.

Kennedy, K.M., E.R. Irwin, M.C. Freeman, and J. Peterson. 2006. Development of a decision support tool and procedures for evaluating dam operation in the southeastern United States. Science Support Partnership Program Final Report to USGS and USFWS. [online] URL: <http://www.rivermanagement.org/reports.html>. Accessed 15 October 2008.

Marcot, B.G., J.D. Steventon, G.D. Sutherland and R.K. McCann. 2006. Guidelines for developing and updating Bayesian belief networks applied to ecological modeling and conservation. *Canadian Journal of Forest Research* 36:3,063–3,074.

McDaniels, T.L., R.S. Gregory, and D. Fields. 1999. Democratizing risk management: Successful public involvement in local water management decisions. *Risk Analysis* 19:497–510.

Netica Software Corporation. 2008. Title. Publisher, Place of publication. [online] URL: <http://www.norsys.com>. Accessed 15 October 2008.

Peterson, J.T., and J.W. Evans. 2003. Quantitative decision analysis for sport fisheries management. *Fisheries* 28(1):10–21.

Poff, N.L., J.D. Allan, M.A. Palmer, D.D. Hart, B.D. Richter, A.H. Arthington, K.H. Rogers, J.L. Meyer, and J.A. Stanford. 2003. River flows and water wars: Emerging science for environmental decision making. *Frontiers in Ecology and the Environment* 1:298–306.

Richter, B.D., and G.A. Thomas. 2007. Restoring environmental flows by modifying dam operations. *Ecology and Society* 12(1):12. [online] URL: <http://www.ecologyandsociety.org/vol12/iss1/art12/>. Accessed 15 October 2008.

Slovic, P., B. Fischhoff, and S. Lichtenstien. 1977. Behavioral decision theory. *Annual Review of Psychology* 18:1–39.

Walters, C.J. 1986. *Adaptive Management of Renewable Resources*. Macmillan, New York.

Williams, B.K., R.C. Szaro, and C.D. Shapiro. 2007. *Adaptive Management: The U.S. Department of the Interior Technical Guide*. U.S. Department of the Interior, Adaptive Management Working Group, Washington DC.

Climate, Geology, and Geomorphology—Abstracts

Considerations in Defining Climate Change Scenarios for Water Resources Planning

L.D. Brekke

Abstract

During the past several years, there has been considerable growth in the amount of climate projection information available for resources impacts assessments. This growth has stemmed largely from the coordination efforts of the World Climate Research Programme's Coupled Model Intercomparison Project-phase 3 (WCRP CMIP3) and the data hosting services of the Lawrence Livermore National Laboratory's Program for Coupled Model Diagnosis and Intercomparison (PCMDI). Through these efforts, resource planners now have access to well over a hundred projections of 21st-century climate, collectively produced by more than 20 coupled ocean-atmosphere climate models. Each model simulates climate response to multiple future trajectories of greenhouse gas emissions, and each model-emissions pairing is used for potentially repeated simulations to factor in the influence of climate-state initial conditions. Extending from this effort, a 112-member subset of statistically downscaled WCRP CMIP3 climate projections has been developed over the contiguous United States and is publically available at http://gdo-dcp.ucllnl.org/downscaled_cmip3_projections/. Given the availability of this amount of information, the following questions arise:

- Rather than consider all available climate projections as equally plausible, should planning initially involve an analysis to determine and identify a more "credible" subset?
- Focusing on the set of climate projections considered (culled or not), how might we select a smaller set of projections that encapsulate the collective and represent a range of future climates?

The Bureau of Reclamation has recently conducted research and demonstrations in both of these question areas. For the first question, findings will be shown to illustrate the challenges of choosing a "correct" set of metrics for which projections can be reliably rated as more or less credible. Findings will also be shown on how doing so still may not reduce perceived climate projection uncertainty. For the second question, a recent planning application in California's Central Valley will be highlighted where projections from the statistically downscaled projections archive mentioned above were surveyed in order to select a set of bracketing climate projections that encapsulated the whole and represented a plausible set of future climates for the given planning application. Four factors drove projection selection: (1) climate periods between which changes are assessed, (2) climate metrics relevant to the resources being studied, (3) geographic location of climate change relevant to resources being studied, and (4) metrics' change ranges of interest within the collective of projections surveyed. Strengths and weaknesses of this projection selection approach will be highlighted.

Brekke is with the Bureau of Reclamation Technical Service Center (86-68210), Denver Federal Center, Denver CO, 80225-0007. Email: lbrekke@do.usbr.gov.

Understanding the Effects of Climate Change in the Yukon River Basin through a Synergistic Research Approach

Michelle Walvoord, Paul Schuster, Rob Striegl

Abstract

Climatic warming in northern latitudes is resulting in a longer growing season, permafrost warming, thermokarst formation, enhanced glacier melting, and earlier ice breakup of lakes and rivers. The Yukon River Basin located in northwestern Canada and central Alaska has extensive permafrost of varying distribution and thickness that is degrading. The basin drains 854,700 km² and supports a population of approximately 126,000 people, 10 percent of which rely heavily on the basin's fish and game resources for their subsistence or livelihood (Brabets et al. 2000). The 3,300-km-long Yukon River and its major tributaries also supply drinking water for towns and villages in the interior of Alaska and provide routes for travel by local residents and for migration by spawning salmon. Therefore, streamflow timing is important from both water resource management and ecologic sustainability perspectives. Recent findings indicate a shift in streamflow behavior toward increased flow during the winter months when the large streams are fed by groundwater, an earlier spring peak, and decreased flow during summer months when streams are fed predominately by surface water runoff. These shifts in streamflow timing may be attributed, in large part, to permafrost thawing and a deepened groundwater flow system. A trend analysis shows the proportion of groundwater to total annual discharge from the Yukon River Basin increasing by 0.9 percent per year over the past several decades (Walvoord and Striegl 2007). Groundwater is depleted in organic constituents and enriched in inorganic constituents relative to surface water due to increased organic matter mineralization and inorganic weathering. Thus, a change in source water is expected to be accompanied by a shift in surface water chemical composition. The observed shift in streamflow timing and source water supports water chemistry data collected from the Yukon River and its major tributaries during a recent U.S. Geological Survey (USGS) water quality study (2001–2005) that indicate a historical decrease in summer–autumn dissolved organic carbon export and an increase in dissolved inorganic carbon export relative to water yield (Striegl et al. 2005). One of the main focuses of the 5-yr water quality study was to establish a baseline that would provide an important frame of reference to assess future changes in the basin that may result from a warming climate and permafrost thawing.

As the 5-yr water quality study neared its conclusion, the USGS began to foster a relationship with the Yukon River Inter-Tribal Watershed Council (YRITWC), a local grassroots organization representing more than 60 tribal councils and First Nations throughout the Yukon River Basin. The YRITWC was in the process of building a steward-based water-quality program. Through a collaborative effort, USGS and YRITWC developed and implemented a basin-wide water-quality program modified from the 2001–2005 study. The YRITWC program began in March 2006, utilizing USGS protocols and techniques. The USGS continues to provide annual training, technical support, in-kind sample analyses, and data interpretation. For three consecutive years (2006–2008), over 350 samplings and field measurements at more than 25 locations throughout the basin have been completed. Basic field measurements include pH, specific conductance, dissolved oxygen, and water temperature. Samples collected for laboratory analyses include major ions, dissolved organic carbon, greenhouse gases, selected trace elements, nutrients, and stable isotopes of hydrogen and oxygen. Field replicates and blanks were introduced into

Walvoord, Schuster, and Striegl are research hydrologists with the U.S. Geological Survey, Lakewood, CO, and Boulder, CO. Email: walvoord@usgs.gov; pschuste@usgs.gov; rstriegl@usgs.gov.

the program in 2007 for quality assurance. The USGS-YRITWC partnership continues to play an important supportive role in the ongoing USGS Yukon River Basin research by providing cost-effective, high-quality water chemistry data from remote basin-wide locations and by building toward a long-term database vital to climate change research.

References

Brabets, T.B., B. Wang, and R.H. Meade. 2000. Environmental and hydrologic overview of the Yukon River Basin, Alaska and Canada. U.S. Geological Survey Water-Resources Investigations Report 99-4204.

Striegl, R.G., G.R. Aiken, M.M. Dornblaser, P.A. Raymond, and K.P. Wickland. 2005. A decrease in discharge-normalized DOC export by the Yukon River during summer through autumn. *Geophysical Research Letters* 32:L21413.

Walvoord, M.A., and R.G. Striegl. 2007. Increased groundwater to stream discharge from permafrost thawing in the Yukon River basin: Potential impacts on lateral export of carbon and nitrogen. *Geophysical Research Letters* 34:L12402.

Impacts of Coalbed Methane Development on Water Quantity and Quality in the Powder River Basin

G.B. Paige, L.C. Munn

Abstract

The Powder River Basin (PRB) in northeastern Wyoming has large coal deposits and large (39 Tcf) reserves of coalbed methane (CBM). To produce CBM from wells installed in the coal seams, water (often groundwater) is pumped to depressurize and release the gas. In many cases large quantities of water are produced along with the CBM natural gas. Currently, there are 24,115 CBM wells in the PRB and each well produces approximately 12,600 gallons/day of produced water. Total production of produced water across all Wyoming coal fields could total roughly 7 million acre-feet (55.5 billion barrels) if all of the recoverable CBM gas in the projected reserves were produced over the coming decades. The water quality of the produced water varies and increases in both salinity and sodicity as one moves north and west across the PRB. The majority of the produced water is discharged into stream channels or impounded in ponds. Management of the co-produced water, beneficial use of the water, and protection of soil and vegetation resources within the PRB are of prime concern. Management alternatives and treatments are discussed based on potential short- and long-term effects on energy development and resources in the PRB and other western watersheds.

Paige and Munn are faculty at the University of Wyoming, Department of Renewable Resources, 1000 E. University Ave., Laramie, WY 82071. Email: gpaige@uwyo.edu; lcmunn@uwyo.edu.

Paleoflood Research of South Boulder Creek Basin near Boulder, Colorado

R.D. Jarrett, J.C. Ferris

Abstract

The highly urbanized city of Boulder in Boulder Creek Basin is considered one of the most at-risk communities for flash flooding in Colorado. Boulder is located at the base of the Colorado Front Range foothills with its headwaters at the Continental Divide. South Boulder Creek (SBC) contributes substantially to the city's flood hazard. Four floodplain studies have been completed for SBC since 1969, producing varying flood-frequency estimates and, thus, large uncertainties in flood frequency (e.g., the 100-year flood varied from 122 to 223 m³/s). In 2008, the City of Boulder completed a new floodplain study to better define flood hydrometeorology, flood frequency, and flood inundation for SBC. To complement the City of Boulder's study, paleoflood research was done along SBC and most tributaries from the headwaters to Eldorado Springs just south of Boulder, where urbanization and channel disturbance precludes paleoflood studies.

Paleoflood data using bouldery flood deposits and non-inundation surfaces were used to document maximum flood discharges, and relative age methods were used to date paleofloods that have occurred during the last 10,000 years. Hydraulic reevaluation and paleoflood data for the 1938 flood of record (209 m³/s) at the SBC streamflow gaging station at Eldorado Springs (42.1 km²) indicated the flood was overestimated by about 40 percent; the revised 1938 flood is 147 m³/s. The expected moments algorithm was used with stream gage data (annual peaks and a mixed-population analysis of annual rainfall and snowmelt peaks) and paleoflood data to better define flood-frequency relations. The revised 100-year flood is 102 m³/s. Analysis of paleoflood data also was used to define five distinct hydroclimatic regions for SBC. The most notable region extends from the base of the foothills west about 20 km (about 15 percent of the basin area) and is most prone to extreme flash flooding during storms. Snowmelt and low to moderate rainfall runoff regions define the remainder of the basin, and they contribute little to the largest floods. Paleoflood data also were used to define the footprint of the 1938 rainstorm; it is essentially the same as an independently reconstructed footprint of the 1938 rainstorm using historical rainfall data and meteorologic analysis. This cost-effective approach provided data on extreme floods critical to a better understanding of Boulder's flood risk and can be used in other regions.

Jarrett and Ferris are research hydrologists with the U.S. Geological Survey, Denver, CO, and Sacramento, CA, respectively. Email: rjarrett@usgs.gov; jcferris@usgs.gov.

Climate, Geology, and Geomorphology— Manuscripts

Evaluating Hydrological Response to Forecasted Land-Use Change: Scenario Testing with the Automated Geospatial Watershed Assessment (AGWA) Tool

William G. Kepner, Darius J. Semmens, Mariano Hernandez, David C. Goodrich

Abstract

Envisioning and evaluating future scenarios has emerged as a critical component of both science and social decision-making. The ability to assess, report, map, and forecast the life support functions of ecosystems is absolutely critical to our capacity to make informed decisions to maintain the sustainable nature of our ecosystem services now and into the future. During the past two decades, important advances in the integration of remote imagery, computer processing, and spatial-analysis technologies have been used to develop landscape information that can be integrated with hydrologic models to determine long-term change and make predictive inferences about the future. Two diverse case studies in northwest Oregon (Willamette River basin) and southeastern Arizona (San Pedro River) were examined in regard to future land use scenarios relative to their impact on surface water conditions (e.g., sediment yield and surface runoff) using hydrologic models associated with the Automated Geospatial Watershed Assessment (AGWA) tool. The base reference grid for land cover was modified in both study locations to reflect stakeholder

preferences 20 to 60 yrs into the future, and the consequences of landscape change were evaluated relative to the selected future scenarios. The two studies provide examples of integrating hydrologic modeling with a scenario analysis framework to evaluate plausible future forecasts and to understand the potential impact of landscape change on ecosystem services.

Keywords: hydrological process models, alternative futures, scenario analysis, watershed assessment, ecosystem services, San Pedro River, Willamette River

Introduction

The Environmental Protection Agency (EPA) ecological research program is currently engaged in a major new National project centered on “ecosystem services,” a core international theme which was brought to the global forefront by the Millennium Ecosystem Assessment (MEA; 2005). The central premise of the MEA is that human condition is intrinsically linked to the environment and that human health and well-being (including economic prosperity) depends on important supportive functions as well as regulating, provisioning, and cultural services provided by our surrounding ecosystems. The EPA is in the process of redirecting its ecological research program to respond to the challenges identified by the MEA and is providing a new emphasis on integration, application, and transformative research and education.

Kepner is a research ecologist, U.S. Environmental Protection Agency, Landscape Ecology Branch, Las Vegas, NV 89119. Email: kepner.william@epa.gov. Semmens is a research physical scientist, U.S. Geological Survey, Denver, CO. Hernandez is a research hydrologist, U.S. Department of Agriculture, Agricultural Research Service, Tucson, AZ. Goodrich is a research hydraulic engineer, U.S. Department of Agriculture, Agricultural Research Service, Tucson, AZ.

EPA scientists in Las Vegas, NV, along with their U.S. Department of Agriculture (USDA) Agricultural Research Service (ARS) and University of Arizona colleagues in Tucson have teamed together to develop a geographical information systems (GIS) interface to rapidly apply two hydrological process models: Soil and Water Assessment Tool (SWAT; Arnold and Fohrer 2005) and KINematic Runoff and EROSION (KINEROS2; Semmens et al. 2008; Smith et al. 1995). The two models have been combined into the Automated Geospatial Watershed Assessment (AGWA) tool for the purpose of conducting watershed assessments at multiple temporal and spatial scales (Miller et al. 2007). AGWA's current outputs are runoff (volumes and peaks) and sediment yield, plus nitrogen and phosphorus with the SWAT model.

Scenarios, as defined by the Intergovernmental Panel on Climate Change, are "plausible and often simplified descriptions of how the future may develop based on a coherent and internally consistent set of assumptions about driving forces and key relationships" (Houghton et al. 2001). Scenario analysis is an approach for evaluating various rational choices and the respective trajectories that lead to alternative future events. In the realm of natural sciences this is typically accomplished by using a combination of land-use change and process models to develop an artificial representation of the physical manifestations of scenario characteristics and to establish a multidisciplinary framework within which scenario characteristics may be analyzed. Scenarios are also usually conducted over long time periods (20–50 yrs) and develop a range of stakeholder-driven perspectives (scenarios), which are analyzed in detail for the consequences or benefits of their selection.

The purpose of this study was to examine the impact of urban development relative to the sustainability of water resources, a crucial asset of the western United States, with the intent of providing answers and a process for determining whether urban/agricultural growth patterns can be managed to minimize hydrologic and ecologic impacts.

Study Areas

The early 1990s and the year 2000 were used as a baseline for two western United States study basins, the Willamette River in Oregon and the San Pedro River on the U.S./Mexico border, respectively (Figure 1). Land use was then projected 60 yrs (Willamette) and 20 yrs (San Pedro) into the future for three development options related to conservation, existing land-use and planning trends, and full open urban development (Table 1). The three scenarios for both watersheds reflect changes in population, patterns of growth, and development practices and constraints. In essence, the Conservation Scenario is regarded as the most ecosystem protected or restoration-oriented option. The Plan Trend Scenario reflects current census predictions with zoning options designed to accommodate reasonable urban growth. The Development Scenario is considered the least conservation-oriented option and is most positioned towards a market economy. Typically, as in these examples, scenario (or alternative futures) analysis uses a model-based approach to identify the key variables that reflect environmental change or to examine landscape change relative to specific issues or ecosystem services (Mohammed et al. 2009; Liu et al. 2008 a; Liu et al. 2008 b). The hydrologic responses resulting from the three development scenarios for both the Willamette and San Pedro River basins were evaluated using AGWA. The environmental endpoints related to surface hydrology were selected because they represent fundamentally important ecosystem services (Farber et al. 2006). This research presents an integrated approach to identify areas with potential water-quality problems as a result of land cover change projected by stakeholders within the two river basins. Initially the study areas were examined and reported separately, though the approach is largely similar for both locations. The land cover/use scenarios were obtained from Steinitz et al. (2003) and Baker et al. (2004), in which the alternative courses of action were developed in consultation with local stakeholders for the three basic options listed in Table 1. Other details in regard to hydrological response relative to the future scenarios at each location can be found in Kepner et al. (2008a; Willamette) and Kepner et al. (2004; San Pedro River). Also see Kepner et al. (2008b) for a combined summary.

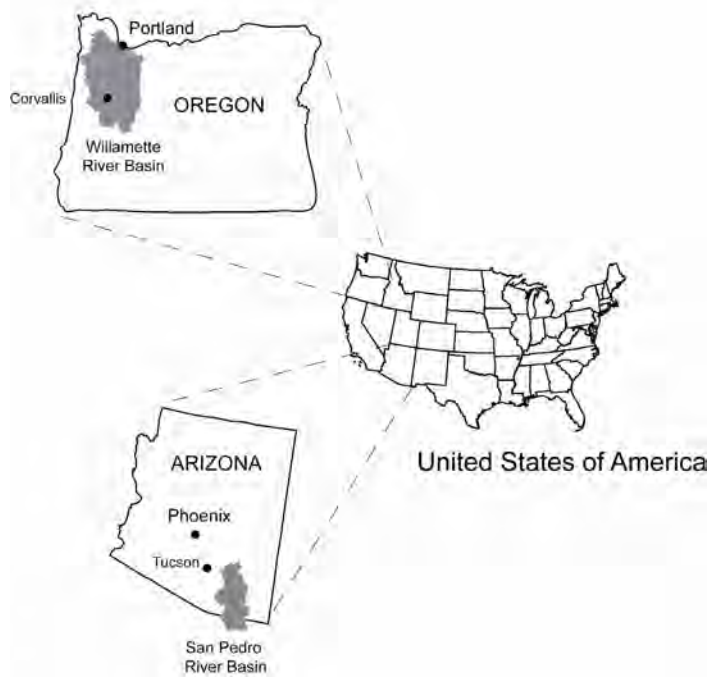

Figure 1. Location of the study areas.

Table 1. Alternative-future scenarios in the Willamette River (OR) and the San Pedro River (U.S./Mexico) basins.

Scenario	Description
Conservation (Constrained)	Places greater priority on ecosystem protection and restoration, although still reflects a plausible balance between ecological, social, and economic considerations as defined by citizen stakeholders.
Plan Trend	Assumes existing comprehensive land-use plans are implemented as written, with few exceptions, and that recent trends continue.
Development (Open)	Assumes current land use policies are relaxed and a greater reliance on market-oriented approaches to land and water use.

Methods

A key feature of AGWA is that it uses commonly available GIS data layers to fully parameterize, execute, and spatially visualize results from both SWAT and KINEROS2 (Figure 2). Through an intuitive interface, users select a watershed outlet from which AGWA delineates and discretizes the watershed using a digital elevation model. The watershed model elements are then intersected with soils and land cover data layers to derive the requisite model input parameters. AGWA can currently use both national (e.g., STATSGO) and international (e.g., FAO) soils data and available land cover/use data such as the National Land Cover Data datasets (Homer et al. 2004). Users are also provided the functionality to easily customize AGWA for use with any classified land cover/use data. The chosen hydrologic model is then executed and the results are imported back into AGWA for visual display. This process allows decision-makers to identify potential problem areas where additional monitoring can be undertaken or mitigation activities can be focused. AGWA can differentiate results from multiple simulations to compare changes predicted for each alternative input scenario (e.g., climate/storm change, land cover change, present conditions, and alternative futures). In addition, a variety of new capabilities have been incorporated into AGWA, including pre- and post-fire watershed assessment, watershed group simulations to cover all watersheds within a political or management boundary, implementation of stream buffer zones, and installation of retention and detention structures. There are currently two versions of AGWA available: AGWA 1.5 for users with Environmental Systems Research Institute (ESRI) ArcView 3.x GIS software (ESRI 2005), and AGWA 2.0 for users with ESRI ArcGIS 9.x (ESRI 2006). AGWA 2.0 utilizes new features in ArcGIS 9.x that are not available in ArcView 3.x to make the tool more powerful, flexible, and easier to use. Both versions have been retained to reach the widest available audience and are provided to users free of charge from both the EPA and USDA/ARS websites (<http://www.epa.gov/esd/land-sci/agwa/index.htm> and <http://www.tucson.ars.ag.gov/agwa/>).

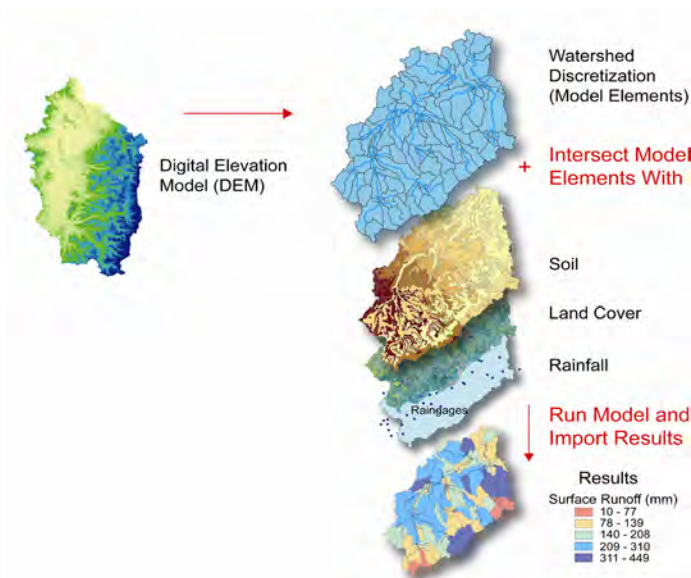

KINEROS Outputs	SWAT Outputs
Channel Infiltration (m ³ /km)	Precipitation (mm)
Plane Infiltration (mm)	ET (mm)
Runoff (mm or m ³)	Percolation (mm)
Sediment Yield (kg)	Surface Runoff (mm)
Peak Flow (m ³ /s or mm/hr)	Transmission Losses (mm)
Channel Scour (mm)	Water Yield (mm)
Sediment Discharge (kg/s)	Sediment Yield (t/ha)
	Nitrate in Surface Runoff (kg N/ha)
	Phosphorous in Surface Runoff (kg P/ha)

Figure 2. AGWA Input/Output variables. SWAT example for surface runoff output in Willamette River Basin, OR.

Results

Results from all AGWA simulation runs for the Willamette River and San Pedro River are displayed in Figures 3 and 4, respectively. The figures show modeled percent change in annual surface runoff, channel discharge, sediment yield, and percolation for each of the three alternative futures, i.e. conservation (constrained), development (open), and plan trend (plans). The baseline year for the Willamette was 1990 and for the San Pedro the baseline year was 2000. The forecasts were provided 60 yrs (Willamette) and 20 yrs (San Pedro) out to the future. For the purpose of this work, negative

impact was considered to be any measurable increase in surface runoff, streamflow discharge, and sediment yield and any decrease in percolation volume. In general, considerable spatial variability for simulated hydrological response was demonstrated in both study locations and for all three scenarios which were applied. However, the most significant changes were associated with increasing urbanization under the development scenario.

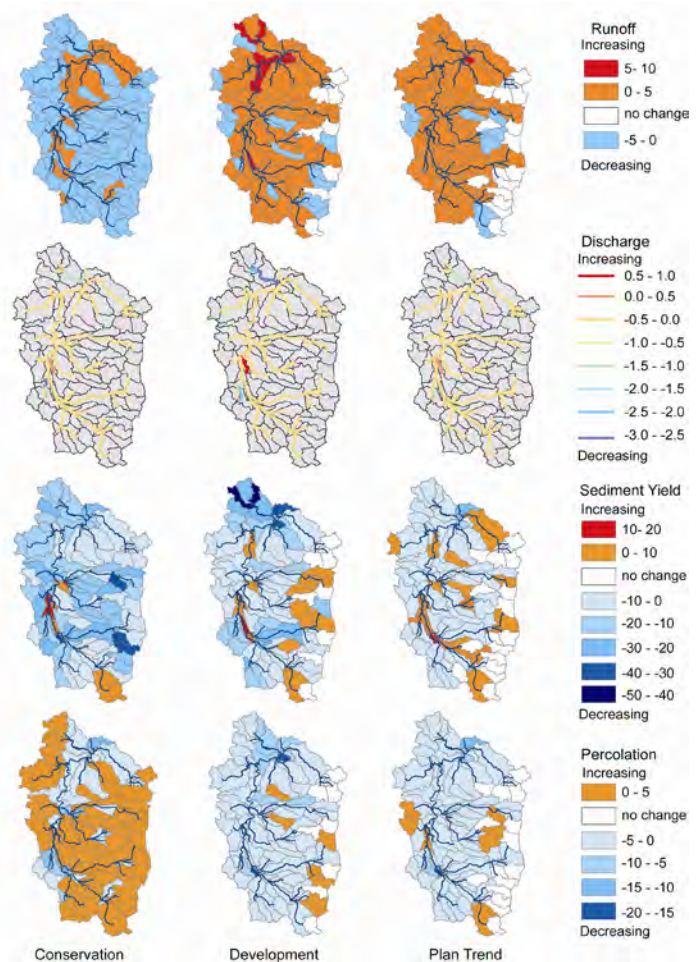

Figure 3. Maps showing modeled percent change in average annual surface runoff, channel discharge, sediment yield, and percolation for each of the three alternative future (2050) scenarios for the Willamette River Basin. Modified after Kepner et al. (2008).

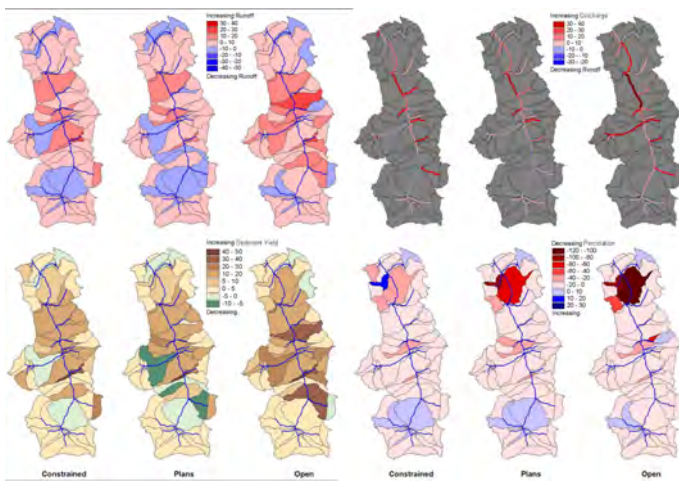

Figure 4. Maps showing modeled percent change in average annual surface runoff (upper left), channel discharge (upper right), sediment yield (lower left), and percolation (lower right) for each of the three alternative future (2020) scenarios for the San Pedro River basin. Modified after Kepner et al. (2004).

Simulation results for the alternative future scenarios indicate that land cover changes associated with potential future development can alter the hydrology of each basin. In addition to the comparative graphic display, results can be quantified and the changes statistically tabulated for comparison. In the example at hand, the purpose was to demonstrate a simple, reliable means for comparing and contrasting some basic options for future urban growth on two diverse watersheds in the western United States.

Conclusions

In general, the simulation results for the alternative future scenarios indicate that land cover changes associated with potential future development can alter the hydrology of each basin, and these changes were quantified and graphically displayed using subwatersheds as a comparative unit. The most significant hydrologic change was associated with urbanization and the associated replacement of vegetated surfaces with impervious ones. The studies demonstrate the ability of integrating digital land cover information (typically derived from satellite sensors) with hydrological process models in the AGWA tool to explore and evaluate options for a future environment. They can provide a scientific underpinning for analyzing one set of ecosystem services related to surface hydrology, and

likely both the approach and technologies could apply to other services and locations. Although the findings in this study were not completely unexpected, the authors believe that spatial modeling and analysis tools, such as AGWA, provide one of the more powerful approaches to envisioning and evaluating plausible future scenarios and potential impacts to our ecosystem services.

References

- Arnold, J.G., and N. Fohrer. 2005. SWAT2000: Current capabilities and research opportunities in applied watershed modeling. *Hydrological Processes* 19(3):563–572.
- Baker, J.P., D.W. Hulse, S.V. Gregory, D. White, J. Van Sickle, P.A. Berger, D. Dole, and N.H. Schumaker. 2004. Alternative futures for the Willamette River Basin, Oregon. *Ecological Applications* 14(2):313–324.
- ESRI. 2005. ArcView, Version 3.x. Environmental Systems Research Institute, Redland, CAA.
- ESRI. 2006. ArcGIS, Versions 9.0, 9.1, and 9.2. Environmental Systems Research Institute, Redland, CA.
- Farber, S., R. Costanza, D. Childers, J. Erickson, K. Gross, M. Grove, C. Hopkinson, J. Kahn, S. Pincetl, A. Troy, P. Warren, and M. Wilson. 2006. Linking ecology and economics for ecosystem management. *BioScience* 56(2):121–133.
- Homer, C., C. Huang, L. Yang, B. Wylie, and M. Coan. 2004. Development of a 2001 national land-cover database for the United States. *Photogrammetric Engineering and Remote Sensing*. 70(7):829–840.
- Houghton, J.T., Y. Ding, D.J. Griggs, M. Noguier, P. J. van der Linden, X. Dai, K. Maskell, and C.A. Johnson, eds. 2001. *Climate Change 2001: The Scientific Basis. Contribution of Working Group I to the Third Assessment Report of the Intergovernmental Panel on Climate Change*. Cambridge University Press, New York.
- Kepner, W., M. Hernandez, D. Semmens, and D. Goodrich. 2008a. *The Use of Scenario Analysis to Assess Future Landscape Change on a Watershed*

- Condition in the Pacific Northwest (USA). In I. Petrosillo, F. Muller, K.B. Jones, G. Zurliini, K. Kranze, S. Victorov, B.-L. Li, and W.G. Kepner, eds., *Use of Landscape Sciences for the Assessment of Environmental Security*, pp. 237–261. Springer, The Netherlands.
- Kepner, W., M. Hernandez, D. Semmens, and D. Goodrich. 2008b. Evaluating hydrological response to forecasted land-use change. In J.C. Campbell, K.B. Jones, J.H. Smith, and M.T. Koeppe, eds., *North America Land Cover Summit*, pp. 275–292. Association of American Geographers, Washington DC.
- Kepner, W.G., D.J. Semmens, S.D. Basset, D.A. Mouat, and D.C. Goodrich. 2004. Scenario analysis for the San Pedro River, analyzing hydrological consequences for a future environment. *Environmental Modeling and Assessment* 94:115–127.
- Liu, Y., H. Gupta, E. Springer, and T. Wagener. 2008a. Linking science with environmental decision making: Experiences from an integrated modeling approach to supporting sustainable water resources management. *Environmental Modelling and Software* 23(7):846–858.
- Liu, Y., M. Mahmoud, H. Hartmann, S. Stewart, T. Wagener, D. Semmens, R. Stewart, H. Gupta, D. Dominguez, D. Hulse, R. Letcher, B. Rashleigh, C. Smith, R. Street, J. Ticehurst, M. Twery, H. van Delden, and D. White. 2008b. Formal Scenario Development for Environmental Impact Assessment Studies. In A. Jakeman, A. Voinov, A. Rizzoli, and S. Chen, eds., *Environmental Modelling, Software and Decision Support: Developments in Integrated Environmental Assessment*, v. 3, pp. 145–162. Elsevier, Amsterdam.
- Millennium Ecosystem Assessment. 2005. *Ecosystems and Human Well-Being: Synthesis*. Island Press, Washington DC.
- Miller, S., D. Semmens, D. Goodrich, M. Hernandez, R. Miller, W. Kepner, and D.P. Guertin. 2007. The Automated Geospatial Watershed Assessment tool. *Environmental Modelling and Software* 22:3, 365–377.
- Mohammed, M., Y. Liu, H. Hartman, S. Stewart, T. Wagener, D. Semmens, R. Stewart, H. Gupta, D. Dominguez, F. Dominguez, D. Hulse, R. Letcher, B. Rashleigh, C. Smith, R. Street, J. Ticehurst, M. Twery, H. van Delden, R. Waldick, D. White, and L. Winter, 2009. A formal framework for scenario development in support of environmental decision-making. *Environmental Modelling and Software* 24(7):798–808.
- Semmens, D.J., D.C. Goodrich, C.L. Unkrich, R.E. Smith, D.A. Woolhiser, and S.N. Miller. 2008. KINEROS2 and the AGWA Modeling Framework: Chapter 5. In H. Wheeler, S. Sorooshian, and K.D. Sharma, eds., *Hydrological Modelling in Arid and Semi-Arid Areas*, pp. 49–69. Cambridge University Press, London.
- Smith, R.E., D.C. Goodrich, D.A. Woolhiser, and C.L. Unkrich. 1995. KINEROS: A Kinematic Runoff and Erosion Model. In V.J. Singh, ed., *Computer Models of Watershed Hydrology*, pp. 697–732. Water Resources Publications, Highlands Ranch, CO.
- Steinitz, C., H. Arias, S. Bassett, M. Flaxman, T. Goode, T. Maddock III, D. Mouat, R. Peiser, and A. Shearer. 2003. *Alternative Futures for Changing Landscapes, the Upper San Pedro River Basin in Arizona and Sonora*. Island Press, Washington DC.

Environmental Effects of Hydrothermal Alteration and Historical Mining on Water and Sediment Quality in Central Colorado

S.E. Church, D.L. Fey, T.L. Klein, T.S. Schmidt, R.B. Wanty, E.H. DeWitt, B.W. Rockwell, and C.A. San Juan

Abstract

The U.S. Geological Survey conducted an environmental assessment of 198 catchments in a 54,000-km² area of central Colorado, much of which is on Federal land. The Colorado Mineral Belt, a northeast-trending zone of historical base- and precious-metal mining, cuts diagonally across the study area. The investigation was intended to test the hypothesis that degraded water and sediment quality are restricted to catchments in which historical mining has occurred. Water, streambed sediment, and aquatic insects were collected from (1) catchments underlain by single lithochemical units, some of which were hydrothermally altered, that had not been prospected or mined; (2) catchments that contained evidence of prospecting, most of which contain hydrothermally altered rock, but no historical mining; and (3) catchments, all of which contain hydrothermally altered rock, where historical but now inactive mines occur. Geochemical data determined from catchments that did not contain hydrothermal alteration or historical mines met water quality criteria and sediment quality guidelines. Base-metal concentrations from these types of catchments showed small geochemical variations that reflect host lithology. Hydrothermal alteration and

mineralization typically are associated with igneous rocks that have intruded older bedrock in a catchment. This alteration was regionally mapped and characterized primarily through the analysis of remote sensing data acquired by the ASTER satellite sensor. Base-metal concentrations among unaltered rock types showed small geochemical variations that reflect host lithology. Base-metal concentrations were elevated in sediment from catchments underlain by hydrothermally altered rock. Classification of catchments on the basis of mineral deposit types proved to be an efficient and accurate method for discriminating catchments that have degraded water and sediment quality. Only about 4.5 percent of the study area has been affected by historical mining, whereas a larger part of the study area is underlain by hydrothermally altered rock that has weathered to produce water and sediment with naturally elevated geochemical baselines.

Keywords: geochemistry, sediment, water, toxicity, aquatic life, mining, hydrothermal alteration

Introduction

A geoenvironmental assessment of central Colorado was conducted on a 54,000-km² area in the central Rocky Mountains (Figure 1). The study area covers the central portion of Colorado, from the New Mexico border on the south to the Wyoming border on the north, and represents about 20 percent of the land area of Colorado. The Colorado Mineral Belt (Tweto and Simms 1963), an area of extensive historical base- and precious-metal mining, cuts diagonally across the study area. The study area contains two National Parks: Rocky Mountain National Park established in 1908 and Great Sand Dunes National Park, formerly a National Monument (1932), established in 2004. Both areas have been set

Church is a senior research geochemist specializing in acid mine drainage issues (<http://amli.usgs.gov/>), Fey is a physical scientist, Klein is an economic geologist, Schmidt is an ecotoxicologist and Mendenhall Fellow, Wanty is an aqueous geochemist, DeWitt is a research geologist, Rockwell is a geologist specializing in remote sensing, and San Juan is a geographic systems expert. All at the U.S. Geological Survey, P.O. Box 25046, MS 973, Denver, CO 80225. Email: schurch@usgs.gov; dfey@usgs.gov; tklein@usgs.gov; tschmidt@usgs.gov; rwanty@usgs.gov; edewitt@usgs.gov; barnabyr@usgs.gov; csanjuan@usgs.gov.

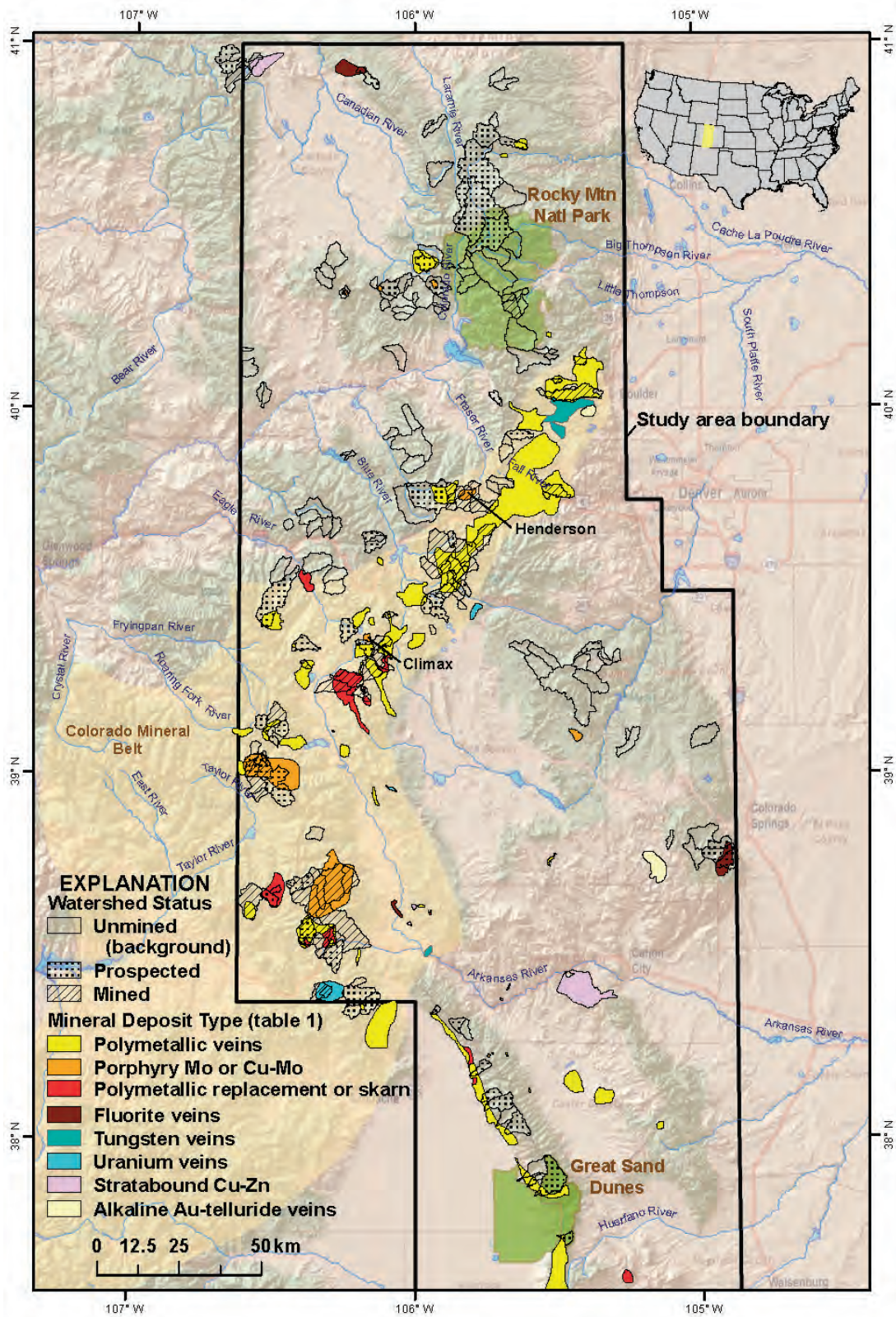

Figure 1. Map of study area showing sampled catchments in central Colorado. The Colorado Mineral Belt (Tweto and Simms 1963) cuts across the study area and outlines the area where most of the base-metal mineralization occurs.

aside and isolated from mineral entry since their establishment. Sample sites in this study are at high altitude, ranging from 1,800 to 3,560 meters above sea level. The climate of the study area is temperate continental with generally more than 50 cm of precipitation per year, especially at higher altitudes. Much of this precipitation occurs as snow in winter or as rain primarily during June through August. Vegetation ranges from deciduous cover at lower altitudes and in riparian zones, to conifer forests, and at the highest altitudes, open tundra (Mutel and Emerick 1992). Federal land management agencies are required to manage their lands for protection and improvement of the aquatic and riparian habitat. The primary objective of the study described in this paper is to evaluate the effects of hydrothermal alteration and historical mining on the water and sediment quality in the study area.

Study Design

Samples of water and unconsolidated sediment were collected from shallow riffle reaches (<0.5-m depth) from 198 small 1st- and 2nd-order streams in central Colorado. The catchments were selected on the basis of public access, physiography, and geology. Catchments sampled in the study area are primarily on public land and have similar gradients, riparian vegetative canopy, and size (median size is 14.75 km², although one catchment is nearly 200 km² in area). To determine the background lithologic metal contribution, water and streambed sediment samples were collected from catchments that were underlain, as much as possible, by a single lithochemical unit (i.e., rocks of similar geochemistry and mode of formation) and that had not been prospected or mined. To determine the metal contribution from hydrothermally altered catchments, additional sample sites were located in catchments that contain historical prospects. Finally, to determine the contribution from historical mining activities, samples were collected from catchments that contain inactive mines. A subset of these catchments was sampled for aquatic macroinvertebrates to determine the population, distribution, and body burden of base metals (Schmidt et al., this volume). Catchments are classified on the basis of disturbance by historical mining. Catchments containing no evidence of historical prospecting (as shown by land disturbance) are classified as unmined or unimpacted (background); those containing prospects, whether or

not those prospects were for base and precious metals or for some other commodity, are classified as prospected; and those catchments containing mines (defined as a site where there is a public record of production of a commodity) are classified as mined. Areas that contain hydrothermal mineralization are color-coded by mineral deposit type (Table 1) on Figure 1.

Methods

Sites from background (undisturbed or unmined) catchments were generally sampled only once during the study. Filtered and unfiltered water samples were analyzed using both inductively coupled plasma–atomic emission spectrometry (ICP-AES) and inductively coupled plasma–mass spectrometry (ICP-MS). Sediments were prepared using total digestion and EPA 3050B leach procedures. Analyses were done using both ICP-AES and ICP-MS. A few duplicate samples of all media were collected at randomly selected sites at the same time to evaluate sampling and analytical reproducibility. Results from duplicate samples were averaged. Replicate samples were collected at the same site in different years. About 20 percent of the sites were replicate sites sampled in one or more field seasons. Samples from catchments containing historical mines and prospects were collected several times during the course of the study. Because previous work has shown that the sediment geochemistry, in particular, is dominated by the colloidal sediment component and that the amount of colloids varies depending on both the time of year and seasonal fluctuations in rainfall (Fey et al. 2002, Church et al. 2007), each sample was treated as a separate observation to determine a range of element concentrations from these disturbed catchments. Both filtered (0.45 µm) and unfiltered water and fine (<177 µm) sediment samples collected from 198 catchments over a 4-yr period (2003–2007) constitute the data set discussed in this paper.

The catchments were classified by disturbance and by hydrothermal alteration type (Figure 2). State (M.A. Sares, 2008, U.S. Forest Service Abandoned Mine Land Inventory, CO, Colorado Geological Survey, unpublished report) and Federal (USGS Mineral Resource Data System, <http://tin.er.usgs.gov/mrds/>, accessed August 2008) databases were used to determine disturbance by mining. The term mine, for the purposes of

Table 1. Characteristics of the principal hydrothermal mineral deposit types found in central Colorado

[Metals, minerals, and alteration types are listed in approximate order of abundance]

Deposit type	Frequency ¹	Metals	Major ore minerals	Minor ore minerals	Gangue minerals	Alteration type and style
Polymetallic veins	73	Ag, Au, Pb, Zn, Cu	pyrite, galena, sphalerite, tetrahedrite, chalcopyrite	argentite, ruby silver	quartz, calcite, siderite, dolomite	argillization, sericitization, silicification, propylitization
Porphyry Mo or Cu-Mo	20	Mo, Cu, Sn, W	molybdenite, chalcopyrite, pyrite	hebnerrite, cassiterite	quartz, fluorite, sericite, topaz	silicification, sericitization, potassium feldspar, propylitization
Polymetallic replacement and skarn	9	Ag, Pb, Zn, Cu	galena, sphalerite, tetrahedrite, pyrite	chalcopyrite, pyrrhotite	dolomite, barite, siderite, fluorite	regional dolomitization, local silicification
Fluorite veins	4	F	fluorite	base metal sulfides, pyrite	quartz, calcite, barite, manganese oxide	argillization, sericitization, silicification
Tungsten veins	--	W	ferberite	pyrite, sphalerite, tetrahedrite, scheelite	quartz, calcite, siderite, barite	silicification, argillization, sericitization, potassium feldspar, propylitization
Uranium veins	3	U, Th, V	uraninite, torbernite, coffinite	base-metal sulfides, pyrite	calcite, ankerite, quartz	argillization, sericitization
Stratabound Cu-Zn	1	Cu, Zn	chalcopyrite, sphalerite, pyrrhotite, pyrite, gahnite	galena, arsenopyrite	amphiboles, chlorite, garnet, sillimanite, epidote, anthophyllite, pyroxene	argillization (metamorphosed to high temperature aluminosilicate minerals)
Alkaline Au-telluride veins	--	Au, Ag, Te	gold, silver, and base metal telluride minerals, native gold	pyrite	quartz, chalcedony, fluorite, calcite, dolomite, hematite, apatite	argillization, silicification, sericitization, potassium feldspar, biotitization

¹Frequency is the intersection of sampled watersheds with mineral deposit types.

production, is restricted, i.e., there must be publically available data indicating that a commodity from the mine site was produced. All other disturbances, such as adits, shafts, and prospect pits, were classified as prospects.

Hydrothermal alteration was mapped and characterized across the study area primarily using mineral maps derived from analysis of Advance Spaceborne Thermal Emission and Reflection Radiometer (ASTER) remote-sensing data. Such maps were supplemented and verified by published

alteration data at local scales (generally from dissertations and wilderness studies) and more detailed mineral maps generated from Airborne Visible/Infrared Imaging Spectrometer (AVIRIS) data. Hydrothermal alteration identified using the ASTER data was classified into types (advanced argillic, argillic ± ferric iron, quartz-sericite-pyrite (QSP), and propylitic) on the basis of spectrally identified mineral assemblages. For example, the QSP alteration type was characterized by the occurrence of ferric iron + sericite ± kaolinite and is referred to in Table 1 by the process terms

seritication and silicification with pyrite. In like manner, the term propylitization refers to the propylitic alteration mineral assemblage, the term dolomitization refers to the conversion of limestone to dolomite, the terms biotization and potassic alteration refer to adding potassium by hydrothermal alteration process to form potassium-bearing minerals such a biotite and potassium feldspar in the hydrothermal alteration suite, and so forth. Several minerals that are associated with alteration may also occur in unaltered sedimentary and metamorphic rocks. Hydrothermally altered areas were differentiated from unaltered areas by applying a 3-km buffer around intrusions and by excluding specific lithochemical units that contain abundant muscovite (e.g., shales and metapelites) and (or) carbonate minerals (limestones and dolomites). The mapping of hydrothermal alteration using remote sensing data is possible only where the ground is not covered by vegetation. Some catchments that have no evidence of historical mining activity (Figure 2) are, nevertheless, hydrothermally altered.

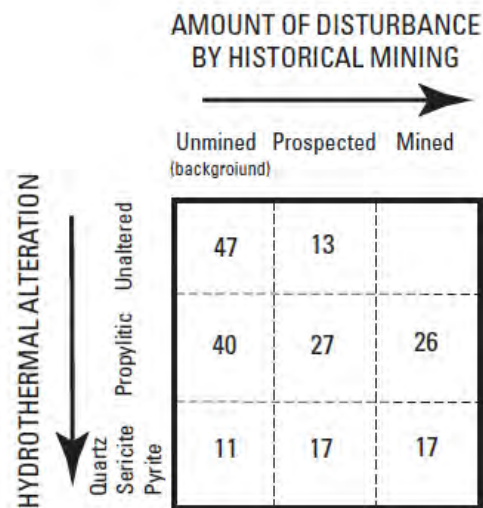

Figure 2. Diagram showing the distribution of samples classified on the basis of hydrothermal alteration and disturbance by historical mining.

Environmental Effects of Hydrothermal Alteration and Historical Mining

Water data

Weathering of pyrite (FeS_2) to release ferrous iron (Fe^{+2}) and sulfate (SO_4^{-2}) is the basic geochemical reaction generally indicative of the presence of

hydrothermal alteration (Plumlee 1999). The oxidation of ferrous to ferric iron (Fe^{+3}) results in a lowering of the pH in surface water. Values of pH ranged between 2.8 and 8.6 (median = 6.99, $n = 262$). Water samples that have low pH have high concentrations of sulfate, which is directly correlated with specific conductance (range of specific conductance is 13–3,000, median = 79.6; Figure 3).

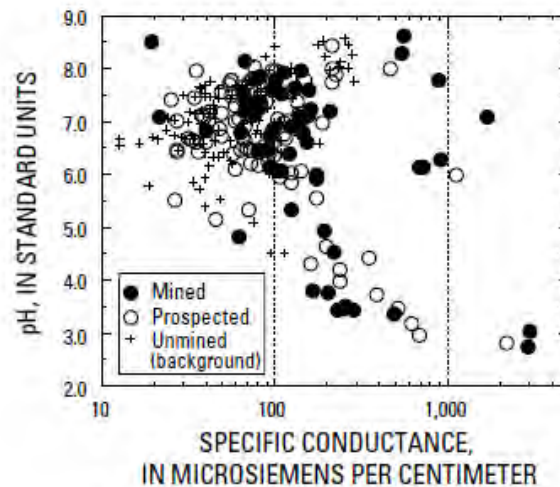

Figure 3. Plot of the relationship of specific conductance to pH in water, by disturbance class.

All samples with low pH and high conductivity are from streams in either prospected or mined catchments; however, the converse is not true. Not all catchments that have been prospected or that contain inactive mines have water that has a low pH or high conductivity (i.e., high concentrations of sulfate). Furthermore, samples from background catchments containing some marine sediment rocks contain evaporate sequences and have high concentrations of sulfate caused by the dissolution of gypsum (Wanty et al. 2009). Metal concentrations in both unfiltered and filtered water samples ($0.45\mu\text{m}$) were analyzed by ICP-MS and ICP-AES to determine metal and sulfate concentrations. Low concentrations of SO_4^{-2} were determined by ion chromatography where the concentrations were below the detection limit (DL) for SO_4^{-2} by ICP-AES. The distributions of base metals (cadmium, Cd; copper, Cu; lead, Pb; and zinc, Zn) and SO_4^{-2} , classified by disturbance, are shown in Figure 4. Dissolved concentrations for the bulk of the background samples for Cd, Cu, and Pb are below the limit of detection by ICP-MS (DL = 0.02, 0.5, and 0.05 $\mu\text{g/L}$, respectively). Concentrations of dissolved Cu and Pb are also censored for some of the prospected catchments

and for most of the background (unmined) catchments. Concentrations of Zn are partially censored (DL = 0.5 $\mu\text{g/L}$) for catchments from both the background and prospected classes. Concentrations of all the base metals (Cd, Cu, Pb, and Zn) and SO_4^{-2} are elevated in water

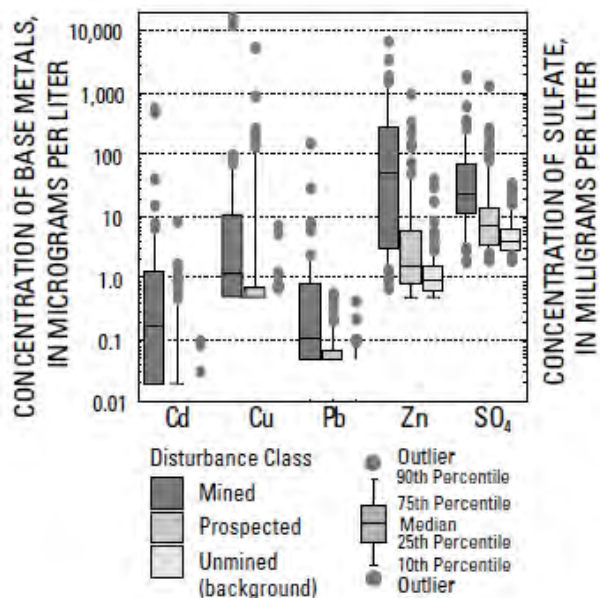

Figure 4. Box plot of the distribution of dissolved base-metal concentrations (cadmium, Cd; copper, Cu; lead, Pb; and zinc, Zn) and sulfate (SO_4^{-2}) in water, by disturbance class (Figure 2).

from catchments containing prospects relative to those from background (unmined) catchments. Likewise, concentrations of both base metals and SO_4^{-2} are elevated in water from catchments containing mines relative to those containing prospects. However, only water samples from mined catchments had significant concentrations of metals (iron, Fe; aluminum, Al; Cd; Cu; Pb; and Zn) that were transported as suspended colloids (Kimball et al. 1995).

Sediment data

Sediment geochemical data (Figure 5) show that there are two very distinct groups of samples and that these groups are not clearly defined on the basis of known disturbance by historical mining. Most, but not all, of the sediment data in the geochemical background (unmined) group plot within the general cluster at the lower left (Figure 5) and have low concentrations of total iron and leachable sulfate. Most, although not all, of the sediment samples from mined catchments and

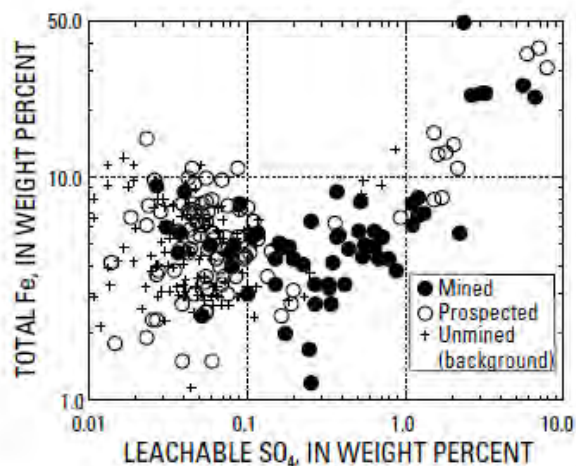

Figure 5. Plot of the concentration of total iron (Fe) and leachable sulfate (SO_4) in sediment, by disturbance class. Two distinct populations are readily apparent. Data from sediment from mined catchments plot largely in the linear array, whereas data from the background population plot in a cluster in the lower left of the figure. Disturbance by historical mining is shown to not be a good descriptor of the geochemical data.

many sediment samples from prospected catchments plot in the linear array of data that show good correlation of increasing total iron with leachable sulfate concentrations that increase and correlate diagonally across the diagram to the upper right corner (Figure 5). In the background group, some of the rocks are from catchments underlain by marine shale that contains gypsum (Wanty et al. 2009). They plot in the low-iron, high-sulfate group. Likewise, those samples from mined catchments that have a low-iron, high-sulfate signature (Figure 5) indicate that disturbance by historical mining has not changed the background lithochemical signature; i.e., they cause little geochemical change in the sediment geochemistry of the catchment. Finally, the fact that some sediment data from the background catchments plot along the high-iron, high-sulfate trend indicates that not all sites of hydrothermal alteration had been explored by prospectors in the past. These unexplored catchments have sediment and water that contain elevated metals and acidity resulting from weathering of altered rock and are unrelated to historical mining.

The major-element geochemistry of the sites varies by hydrothermal alteration type. In comparison with the background catchments, hydrothermal alteration generally resulted in lower median concentrations of

sodium, potassium, and calcium in sediment (data not shown). Median Fe concentration in sediment from mined catchments is somewhat higher and the range of Fe concentrations is larger than that from sediment in background catchments. Concentrations of base metals (Cd, Cu, Pb, and Zn), and of barium (Ba), manganese (Mn), and sulfate are indicative of sulfide mineralization. Figure 6 summarizes the geochemical differences in sediment geochemistry among catchments by disturbance and hydrothermal alteration. The effects of hydrothermal alteration are shown in each panel (Figure 6), whereas the effects of disturbance by historical mining (Figure 2) are shown by comparing the differences between classes in different panels.

There is little difference between the geochemistry of sediment from unmined background and propylitic-altered catchments and sediment from those catchments that are unmined and unexplored that contain some QSP alteration (Figure 6A). At the scale of the catchments sampled, the ASTER-derived mineral maps showed that QSP-altered areas are always smaller (usually on the order of 1 km² or less) than the total catchment area. Furthermore, the QSP-altered areas are surrounded by areas of propylitic alteration. Our attempt to rank the amount of QSP alteration relative to propylitic-altered and unaltered areas within the catchments was not useful in further describing the data. Median concentrations of Mn and Pb in sediment from propylitic-altered catchments are lower than that in sediment from either background or QSP-altered, unmined catchments. In contrast, the median concentration of SO₄⁻² in sediment from QSP-altered catchments is somewhat higher. The ranges of metal concentrations in sediment, as shown by the 25th and 75th percentiles in the QSP-altered, unmined catchments, always have a larger spread than the other two hydrothermal alteration classes. Median concentrations of Cd, Pb, Mn, and Zn are near crustal abundance in unaltered rocks, whereas Cu is lower and Ba higher than crustal abundance values (Fortescue 1992).

The presence of prospects in catchments on sediment geochemistry, regardless of the presence of propylitic hydrothermal alteration, does not substantially affect the median concentrations or ranges of the geochemical data. Median values of all constituents in sediment (Figure 6B) from prospected catchments are very similar to those from the unaltered, unmined catchments

(Figure 6A). Relative to the sediment geochemical data from background catchments, median concentrations of Ba, Mn, Cd, Pb, and Zn show little variation among the three hydrothermal alteration classes. Essentially, the only major difference is that the 75th percentile of the copper and sulfate sediment data in QSP-altered, prospected catchments (Figure 6B) is higher than that in QSP-altered, unmined catchments (Figure 6A). The 75th percentile for both Cu and SO₄⁻² in sediment from catchments containing both prospects and some QSP alteration exceeds the maximum concentration in sediment from the background catchments.

In catchments where historical mining has occurred, the disturbance of hydrothermally altered rock by mining appears to have resulted in substantial release of metals and sulfate (Figure 6C). Although catchments have been mined, some degraded water and sediment quality results from weathering of exposed hydrothermally altered rock. Relative to background sediment data, the median concentrations of Ba, Mn, and SO₄⁻² in sediment from mined catchments increase in sediment from propylitic-altered catchments and are even more elevated in sediment from catchments containing some QSP-altered rock. Furthermore, the range of concentrations of these three constituents in sediment in both classes of hydrothermally altered rock is much greater than the ranges of concentrations in background catchments. Median concentrations of Mn, SO₄⁻², and all four of the base metals in sediment from disturbed catchments are greater than the 75th percentile for sediment from background catchments. For the metals Cd, Cu, and Pb, the median concentrations in sediment from disturbed catchments for both classes of hydrothermal alteration exceed the maximum concentration in sediment from the background catchments. Median concentrations of Zn in sediment from mined, QSP-altered catchments likewise exceed the maximum in background sediment concentrations, whereas median Zn concentrations in sediment from propylitic-altered, mined catchments is within the range of sediment data from background Zn concentrations but is still strongly enriched.

Comparison of Geochemical Data from Hydrothermal Alteration and Disturbance Class with Sediment Quality Guidelines

The consensus probable effects concentration sediment quality guidelines (PEC-SQG; Macdonald et al. 2000) for Cd, Cu, Pb, and Zn are shown on Figure 6. These

guidelines represent the concentration in sediment above which these elements have been shown to have significant toxicity effects on sensitive aquatic life. Rarely do the observed concentrations in sediment from QSP-altered rock in background catchments exceed the PEC-SQG (Figure 6A). However, in catchments where historical prospecting has occurred (Figure 6B), the concentrations of all four metals in a few catchments exceed the PEC-SQG. In mined, propylitic-altered and QSP-altered catchments, the PEC-SQG concentrations of the base metals are often less than the 75th percentile and, in some cases, approach the median value (Figure 6C). The PEC-SQG concentrations of Cd in sediment from these catchments are at the 75th percentile in propylitic-altered catchments and approach the median value in sediment from QSP-altered catchments. The PEC-SQG concentrations of Cu in sediment from these catchments are less than the 75th percentile for both hydrothermal alteration groups. The PEC-SQG concentrations of Pb in sediment are likewise lower than the median value for both groups. And the PEC-SQG concentrations of Zn in sediment are less than the 75th percentile for propylitic-altered catchments and less than the median value for sediment from QSP-altered catchments. Historical mining can be implicated for some of the poor water and sediment quality in the study area; however, it is erroneous to assume that all degraded water and sediment quality is the result of historical mining. Some degraded water and sediment quality results from the weathering of exposed hydrothermally altered rock (Church et al. 2007) that is undisturbed by human activity (Figure 6A).

Figure 6. Box plots of total barium (Ba), manganese (Mn), cadmium (Cd), copper (Cu), lead (Pb), zinc (Zn), and leachable sulfate (SO_4) in sediment.

A. Geochemical data in sediment from background catchments versus catchments containing propylitic and quartz-sericite-pyrite (QSP) altered rock with no mines or prospects. These data correspond to the left-hand column in Figure 2.

B. Geochemical data in sediment from prospected background catchments in relation to sediment data from prospected catchments with propylitic alteration and sediment data from prospected catchments containing some QSP-altered rock. These data correspond to the center column in Figure 2.

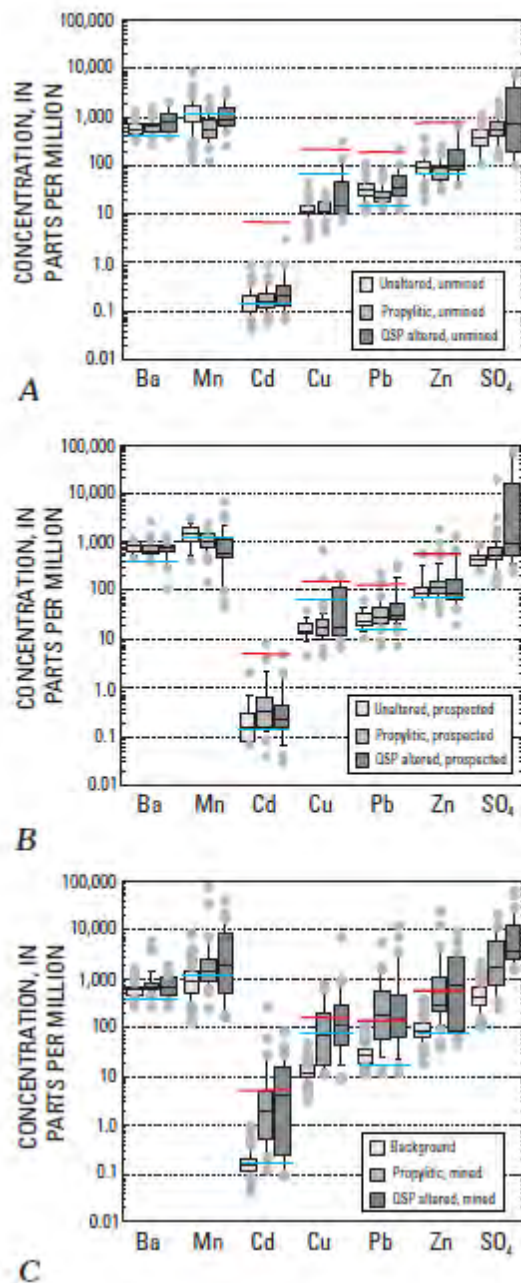

C. Geochemical sediment data from unmined background catchments (both unaltered and propylitic alteration) in relation to sediment data from mined catchments containing either propylitic altered or QSP-altered rock. These data correspond to the right-hand column in Figure 2. The red lines indicate metal concentrations in sediment that are potentially toxic to aquatic life (probable effects concentration, sediment quality guidelines; Macdonald et al. 2000). Blue lines are the crustal abundance concentrations (Fortescue 1992).

Mineral Deposit Data

The mineral deposits in the study area were classified by mineral deposit type (Cox and Singer 1986). Areas of hydrothermal mineralization are shown in Figure 1. Table 1 shows the characteristics of these mineral deposits, including exploited metals, gangue mineralogy, and hydrothermal alteration type. The catchments were reclassified according to their intersection with the mineralized areas. Development of the specific deposit type areas utilized data from the disturbance classes discussed previously but did not rely on the hydrothermal alteration data developed from the AVIRIS and ASTER data. The polymetallic vein type of deposits has the highest frequency of occurrence in sampled catchments (Table 1). Polymetallic veins may constitute a surface expression of and overlie many larger mineral deposit types (Cox 1986 a and b; Ludington 1986; Cox and Singer 1986) that occur within the study area. These polymetallic vein deposits were the target of historical mining at the turn of the twentieth century in Colorado (e.g., Henderson 1926). The numerical and areal abundance of polymetallic vein deposits reflect the exploration history and the level of erosion and exposure in the study area. Porphyry molybdenum (Mo) and Cu-Mo deposits are known in the study area, but only the porphyry Mo deposits at Climax and Henderson have been exploited. Polymetallic replacement and skarn deposits have also been exploited in the western and southwestern part of the study area. The catchments containing uranium vein deposits and fluorite vein deposits were sampled in only a few catchments (Table 1). The stratabound Cu-Zn deposits occur mostly in dry, low-lying terrane that was privately owned and was generally not accessible for sampling. The one catchment that contained a stratabound Cu-Zn deposit that was sampled was lumped with the polymetallic replacement deposits in plotting of the sediment geochemical data (Figure 7). The total area of the mineralized zones is 2,426 km² or 4.5 percent of the study area.

Evaluation of Water and Sediment Quality Data with Mineral Deposit Types

Sediment geochemical data for Cd, Cu, Pb, Zn, and SO₄ categorized by mineral deposit type are presented in Figure 7. The sediment geochemistry from catchments containing base-metal-rich polymetallic veins, porphyry Mo and Cu-Mo deposits, and polymetallic replacement and skarn deposits clearly outline the areas of high base-

metal concentrations. The fluorite and uranium vein deposits do not contribute substantial base metals to sediment in catchments that contain them. In fact, stream sediment from these catchments do not differ significantly from sediment from unmined, background catchments. Mineral deposit type is a better discriminator for elevated base-metal concentrations in the environment than disturbance or hydrothermal alteration. The base-metal distributions (Figure 7), because they are not separated by disturbance class, have a larger range than those shown in Figure 6 but would show similar patterns of metal enrichment if subdivided by disturbance class. High concentrations in the base-metal distributions in Figure 7 represent the sediment geochemistry from mined catchments (Figure 6). The base metals Cd, Cu, Pb, and Zn are enriched in sediment from catchments that contain polymetallic vein, polymetallic replacement, and skarn-type mineral deposits, whereas copper is generally more enriched in sediment from catchments that contain porphyry Cu-Mo and Mo, polymetallic replacement, and skarn-type mineral deposits relative to catchments containing other mineral deposit types. Elevated concentrations of SO₄⁻² in sediment are interpreted to reflect the high abundance of pyrite in the hydrothermal alteration halo of the porphyry mineral deposits (Ludington 1986, Cox 1986b).

[Continued on next page]

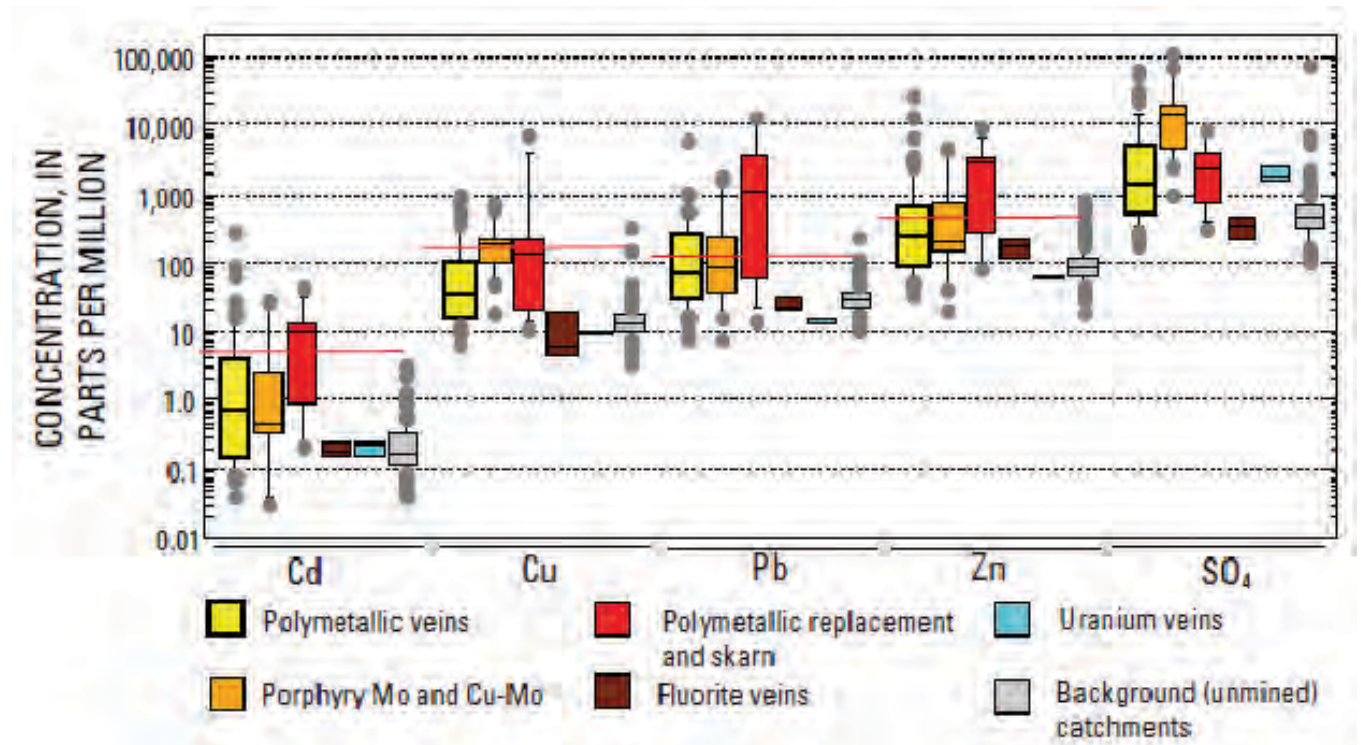

Figure 7. Box plots of total concentration data for cadmium (Cd), copper (Cu), lead (Pb), zinc (Zn), and sulfate (SO₄) in sediment from catchments containing different types of mineral deposits (Table 1). The red lines indicate metal concentrations in sediment that are potentially toxic to aquatic life (probable effects concentration, sediment quality guidelines; Macdonald et al. 2000).

References

Church, S.E., D.L. Fey, and D.M. Unruh. 2007. Trace elements and lead isotopes in modern streambed and terrace sediment: Determination of current and premining geochemical baselines. In S.E. Church, P. von Guerard, and S.E. Finger, eds., *Integrated Investigations of Environmental Effects of Historical Mining in the Animas River Watershed, San Juan County, Colorado*, pp. 571–642. U.S. Geological Survey Professional Paper 1651.

Cox, D.P., 1986a, Descriptive model of polymetallic veins. In D.P. Cox and D.A. Singer, eds., *Mineral Deposit Models*, p. 125. U.S. Geological Survey Bulletin 1693.

Cox, D.P., 1986a, Descriptive model of porphyry Cu. In D.P. Cox and D.A. Singer, eds., *Mineral Deposit Models*, p. 76. U.S. Geological Survey Bulletin 1693.

Cox, D.P., and D.A. Singer. 1986. *Mineral deposit models*. U.S. Geological Survey Bulletin 1693.

Fey, D.L., L. Wirt, J.M. Besser, and W.G. Wright. 2002. Water quality and aquatic toxicity data of 2002 spring thaw conditions in the upper Animas River watershed, Silverton, Colorado. U.S. Geological Survey Open-File Report 02-488.

Fortescue, J.A.C. 1992. Landscape geochemistry: Retrospect and prospect, 1990. *Applied Geochemistry* 7:1–54.

Henderson, C.W. 1926. *Mining in Colorado: A history of discovery, development and production*. U.S. Geological Survey Professional Paper 138.

Kimball, B.A., E. Callender, and E.V. Axtmann. 1995. Effects of colloids on metal transport in a river receiving acid mine drainage, upper Arkansas River, Colorado, U.S.A. *Applied Geochemistry* 10:285–306.

Ludington, S.D. 1986. Descriptive model of Climax Mo deposits. In D.P. Cox and D.A. Singer, eds., *Mineral Deposit Models*, p. 73. U.S. Geological Survey Bulletin 1693.

MacDonald, D.D., C.G. Ingersoll, and T.A. Berger. 2000. Development and evaluation of consensus-based sediment quality guidelines for freshwater ecosystems. *Archives of Environmental Contamination and Toxicology* 39:20–31.

Mutel, C.F., and J.C. Emerick. 1992. *From Grassland to Glacier: The Natural History of Colorado and the Surrounding Region*. Johnson Printing Co., Boulder, CO.

Plumlee, G.S. 1999. The environmental geology of mineral deposits. In G.S. Plumlee and M.J. Logsdon, eds., *The Environmental Geochemistry of Mineral Deposits. Part A: Processes, Techniques, and Health Issues*, pp. 71–116. Society of Economic Geologists, Inc., Littleton, CO.

Tweto, O., and P.K. Simms. 1963. Precambrian ancestry of the Colorado mineral belt. *Geological Society of America Bulletin* 74:991–1,014.

Wanty, R.B., P.L. Verplanck, C.A. San Juan, S.E. Church, T.S. Schmidt, D.L. Fey, E.H. DeWitt, and T.L. Klein. 2009. Geochemistry of surface water in alpine catchments in central Colorado, USA: Resolving host-rock effects at different spatial scales. *Applied Geochemistry* 24:600–610.

U.S. Geological Survey Research in Handcart Gulch, Colorado: An Alpine Watershed with Natural Acid-Rock Drainage

Andrew H. Manning, Jonathan Saul Caine, Philip L. Verplanck, Dana J. Bove, Katherine G. Kahn

Abstract

Handcart Gulch is an alpine watershed along the Continental Divide in the Colorado Rocky Mountain Front Range. It contains an unmined mineral deposit typical of many hydrothermal mineral deposits in the intermountain west, composed primarily of pyrite with trace metals including copper and molybdenum. Springs and the trunk stream have a natural pH value of 3 to 4. The U.S. Geological Survey began integrated research activities at the site in 2003 with the objective of better understanding geologic, geochemical, and hydrologic controls on naturally occurring acid-rock drainage in alpine watersheds. Characterizing the role of groundwater was of particular interest because mountain watersheds containing metallic mineral deposits are often underlain by complexly deformed crystalline rocks in which groundwater flow is poorly understood. Site infrastructure currently includes 4 deep monitoring wells high in the watershed (300–1,200 ft deep), 4 bedrock (100–170 ft deep) and 5 shallow (10–30 ft deep) monitoring wells along the trunk stream, a stream gage, and a meteorological station. Work to date at the site includes: geologic mapping and structural analysis; surface sample and drill core mineralogic characterization; geophysical borehole logging; aquifer testing; monitoring of groundwater hydraulic heads and streamflows; a stream tracer dilution study; repeated sampling of surface and groundwater for geochemical analyses, including major and trace elements, several isotopes, and groundwater age dating; and construction of groundwater flow

models. The unique dataset collected at Handcart Gulch has yielded several important findings about bedrock groundwater flow at the site. Most importantly, we find that bedrock bulk permeability is nontrivial and that bedrock groundwater apparently constitutes a substantial fraction of the hydrologic budget. This means that bedrock groundwater commonly may be an underappreciated component of the hydrologic system in studies of alpine watersheds. Additionally, despite the complexity of the fracture controlled aquifer system, it appears that it can be represented with a relatively simple conceptual model and can be treated as an equivalent porous medium at the watershed scale. Interpretation of existing data, collection of new monitoring data, and efforts to link geochemical and hydrologic processes through modeling are ongoing at the site.

Keywords: hydrologic observatory, watershed, alpine, mountain, groundwater, acid-rock drainage

Introduction

The Handcart Gulch research site was developed by the U.S. Geological Survey (USGS) in 2003 with the objective of better understanding geologic, geochemical, and hydrologic controls on naturally occurring acid-rock drainage in alpine watersheds. Characterizing the groundwater system was of particular interest because groundwater's role in the generation and transport of acid-rock drainage in mineralized mountain watersheds is poorly understood due to a lack of wells in these settings.

The 1.5-mi² site includes the upper portion of an alpine watershed in the Colorado Rocky Mountain Front Range and is at an elevation of 10,700–12,800 ft (Figure 1). The watershed is underlain by complexly folded and fractured Precambrian metamorphic rocks.

Manning, Caine, Verplanck, and Bove are research geologists, U.S. Geological Survey, Denver, CO. Kahn is a hydrogeologist, Cameron-Cole, LLC, Boulder, CO. Email: amanning@usgs.gov; jscaine@usgs.gov; plv@usgs.gov; dbove@usgs.gov; klgurley@hotmail.com.

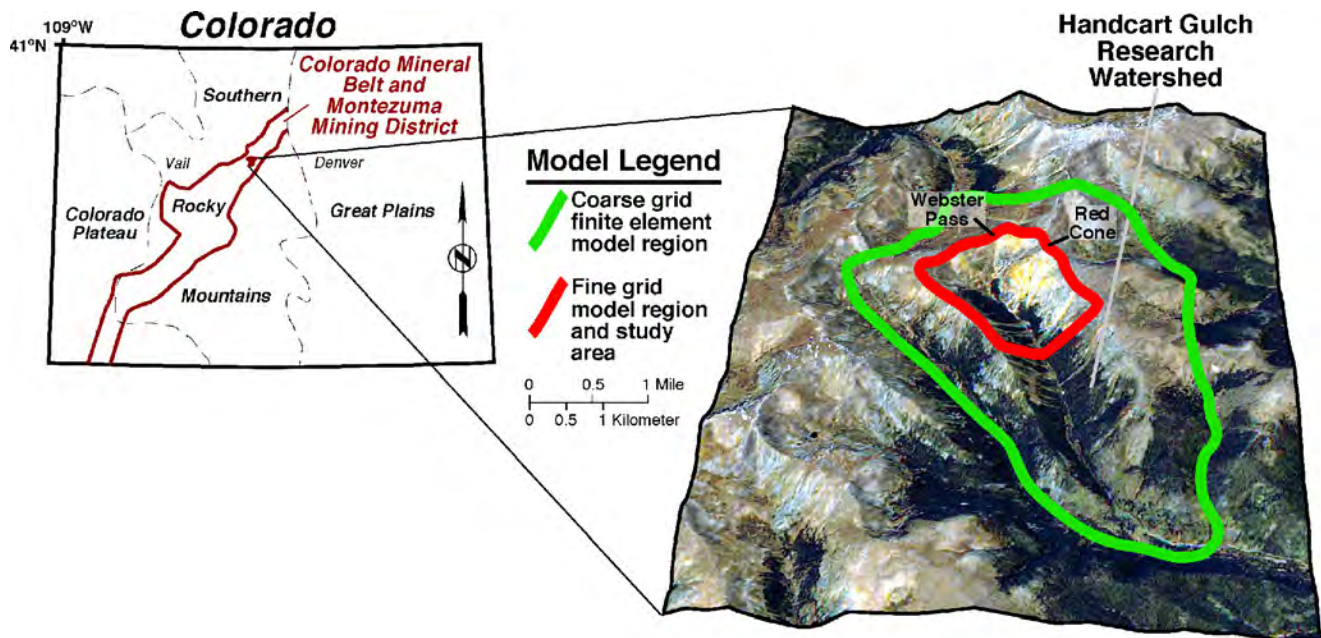

Figure 1. Location of Handcart Gulch in the Colorado Mineral Belt. The study area boundary (red) and numerical groundwater flow model domains (red and green) are also shown on a visible satellite image draped on a tilted digital elevation model.

It is located in the Montezuma Mining District, which lies within the Colorado Mineral Belt. The small perennial stream (flows of 0.1–4.5 ft³/S) draining the site has a natural pH of 3 to 4, a result of the presence of an unmined mineral deposit composed primarily of pyrite with trace metals including copper and molybdenum.

The site's most unique feature is that it includes 13 groundwater monitoring wells ranging in depth from 10 to 1,200 ft. Mountain hydrologic research to date has focused on the surface water system, and monitoring wells extending to depths greater than a few feet are rare in alpine environments worldwide. Handcart Gulch thus provides the opportunity to address fundamental questions regarding mountain groundwater flow, such as: Is the bulk permeability of fractured crystalline bedrock sufficiently low (as is commonly assumed) to ignore bedrock-hosted groundwater in watershed hydrologic models? If not, what are typical bedrock groundwater flow rates and dissolved mass fluxes? What are typical water table elevations? To what degree do discrete geologic features, such as fracture networks and fault zones, localize groundwater flow paths, and at what scale might the bulk permeability structure be treated as a continuum? What geologic factors control the concentrations and fluxes of acid, metals, and other dissolved constituents in mountain groundwater flow systems? A better

understanding of the role of groundwater in mountain watershed hydrology will allow us to better predict how changes in land use and climate will affect water quality and quantity in mountain watersheds.

This paper provides an overview of USGS research in Handcart Gulch and a brief synopsis of preliminary results from the site. More detailed information can be found in the following publications: Caine et al. (2006), Manning and Caine (2007), Kahn et al. (2007), Verplanck, Manning, et al. (2007), and Verplanck, Nordstrom, et al. (in press).

Site Instrumentation and Data

In the summers of 2001 and 2002 a private mineral exploration company (Mineral Systems, Inc.) drilled and cored four deep mineral exploration boreholes in Handcart Gulch (WP1–WP4; Figure 2). The wells are located in the upper part of the watershed, the highest one being on the Continental Divide at an altitude of 12,100 ft (WP1; Figure 2). Borehole depths range from 1,200 to 3,500 feet. Mineral Systems, Inc. donated the boreholes and drill core to the USGS, who reconditioned the boreholes for use as monitoring wells. The deep monitoring wells are screened continually or are open within the bedrock and have depths of 300 to 1,200 ft (borehole collapses prevented completing the wells to greater depths). The deep wells

were supplemented with four new wells screened in the bedrock (100–170 ft deep) and five new wells screened in the overlying surficial material (10–30 ft deep). These nine new wells are located in five well nests adjacent to the trunk stream (HCBW1–HCBW4 and HCFW5; Figure 2). In addition to the wells, the site includes a stream gage and a meteorological station.

From 2003 to 2005, a variety of data were collected from the watershed: (1) basic geologic, fracture network, and fault data as well as alteration mineralogy and elemental geochemistry from both outcrop and drill-core rock samples; (2) geophysical borehole-logging data (Figure 3); (3) water level and single-well aquifer test data; (4) stream metal loading data from a tracer-dilution study in the trunk stream; (5) streamflow data from the trunk stream; and (6) a host of geochemical data from surface water and groundwater samples, including concentrations of major and trace elements, multiple stable isotopes (of strontium, sulfur, oxygen, and hydrogen), dissolved noble gases (including ^3He), and residence time indicators (tritium, chlorofluorocarbons, and carbon isotopes).

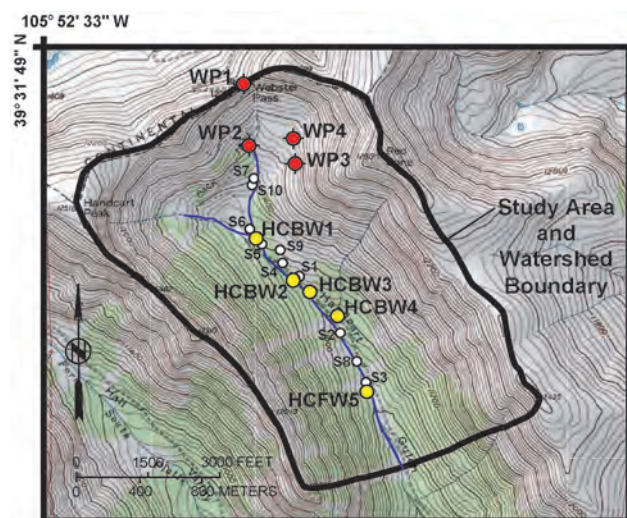

Figure 2. Topographic map of Handcart Gulch study area showing well locations. Deep wells (WP1–WP4) shown in red, shallow well clusters near trunk stream (HCBW1–HCBW4 and HCFW5) shown in yellow. Springs (S1–S10) are also shown in white. Base map from U.S. Geological Survey Montezuma Quadrangle, 1:24,000 (1958).

Monitoring activities at the site are ongoing. Water table elevations and ground temperatures are continuously monitored using dedicated pressure transducers and thermistors. Stream discharge and meteorological data will be continuously monitored starting in summer 2008. Stream and groundwater samples are collected annually for geochemical analyses. An important objective of these long-term monitoring activities is to identify and better understand watershed hydrologic and geochemical responses to climate change.

Preliminary Results

Outcrop and well-log data indicate that the bedrock is complexly deformed and primarily consists of tightly folded felsic and mafic Precambrian metamorphic rocks. Several types of geologic structures are present, but only the open-joint networks appear to be important in conducting groundwater flow. Down-hole televiewer data indicate pervasive, high-intensity open-joint networks at all depths logged. Flow metering performed in concert with the televiewer logging revealed few discrete inflows or outflows associated with individual structural features (Figure 3). The dominant hydrothermal alteration assemblage is quartz-sericite-pyrite (QSP), commonly found in felsic lithologies with an average concentration of about 8 weight-percent fine-grained, disseminated pyrite and quartz-pyrite veinlets. These are the primary source rocks for natural acid-rock drainage at the site. The intensity of hydrothermal alteration decreases away from Webster Pass and Red Cone and transitions outward from QSP to propylitic alteration to relatively unaltered rocks (Figure 1). The pervasive hydrothermal QSP alteration extends to as much as 3,000 ft below the ground surface.

Seasonal water-table fluctuations observed in wells in the upper part of the watershed are very large (up to about 150 ft). Dissolved gas data indicate unusually high excess air concentrations in bedrock groundwater along the stream, suggesting that the large water table fluctuations are ubiquitous throughout upper portions of the watershed (Manning and Caine 2007). Seasonal cycles of saturation and oxygenation in the thick unsaturated zone may be an important mechanism controlling pyrite oxidation and the liberation of acid and metals to ground and surface waters.

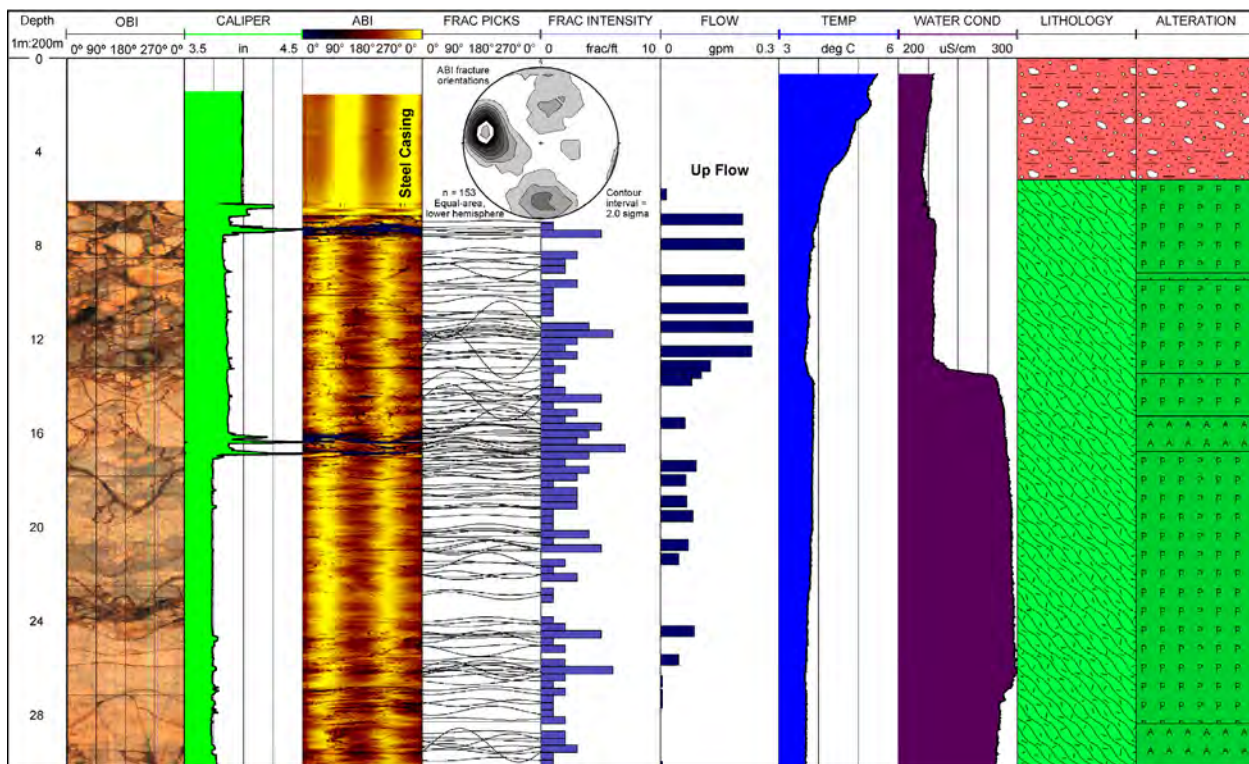

Figure 3. An example of composite geophysical and lithological logs from Handcart Gulch wells. Optical televiwer image (OBI) shows top of bedrock and sinusoidal traces of open fractures in WP4 (all other logs are from shallow well HCBW1 next to the trunk stream). Fracture orientations derived from the acoustic televiwer image (ABI) plotted on an equal area projection are consistent with outcrop and regional fracture orientations. Heat-pulse flow meter data (FLOW) indicates flow direction and magnitude in the well.

Artesian conditions exist in the bedrock near the trunk stream. Static water levels of up to 10 ft above ground surface and sustained or seasonal artesian flows of up to 20 gallons/min were observed in the bedrock wells along the trunk stream. The artesian conditions are probably caused at least in part by a thick layer (up to 40 ft) of well-indurated ferricrete (iron-oxide cement) present beneath the stream. The ferricrete apparently forms a confining unit that impedes groundwater discharge to the stream. As a result, much of the bedrock groundwater may flow down-drainage underneath the stream and discharge at an unknown location.

Single-well aquifer test data were used to estimate hydraulic conductivities (K) and specific storage values (S) for the surface deposits and bedrock. Derived K and S values for the surficial deposits were about 10^{-6} to 10^{-5} m/s and about 10^{-4} to 10^{-3} per meter, respectively, and values for the bedrock were about 10^{-9} to 10^{-6} m/s and about 10^{-5} to 10^{-4} per meter, respectively (Kahn et al. 2007). The bedrock K values are sufficiently high to allow substantial groundwater flow and suggest that

bedrock-hosted groundwater may be an important component of the hydrologic budget.

Temperature-depth profiles from the deep wells become nearly linear at depths greater than about 300 ft below the water table (greater than about 600 ft below ground surface), suggesting that active groundwater circulation does not exceed these depths (Manning and Caine 2007).

A tracer-dilution study (Kimball et al. 2002) conducted in the upper 2 km of the trunk stream indicated that discharge, acidity, and loading of zinc and copper increase in the downstream direction, and zinc and copper concentrations exceed aquatic-life standards.

Groundwater samples from Handcart Gulch are Ca-SO₄ type and range in pH from 2.5 to 6.8. Most samples (75 percent) have pH values between 3.3 and 4.3 (Verplanck, Manning, et al. 2007). Surface water samples are also Ca-SO₄ type and have a narrower range in pH (2.7 to 4.0). Groundwater and surface water samples vary from relatively dilute (specific

conductance of 68 $\mu\text{S}/\text{cm}$) to concentrated (2,000 $\mu\text{S}/\text{cm}$). Compared to other unmined, porphyry-mineralized areas in the Southern Rocky Mountains, dissolved copper concentrations in Handcart Gulch ground and surface waters are relatively high (10 to 1,000 $\mu\text{g}/\text{L}$) and dissolved zinc concentrations are relatively low (10 to 300 $\mu\text{g}/\text{L}$) (Verplanck, Nordstrom, et al., in press).

Tritium/helium ($^3\text{H}/^3\text{He}$) groundwater age results indicate increasing groundwater age with depth (Figure 4) (Manning and Caine 2007). Mean ages from integrated bedrock groundwater samples collected near the trunk stream are very similar. These data are consistent with a relatively simple conceptual model of the flow system in which recharge and aquifer thickness are constant throughout the drainage. They also suggest that the watershed aquifer system can be represented as an equivalent porous media using a numerical groundwater flow model in spite of the complexities in the geology and fracture networks.

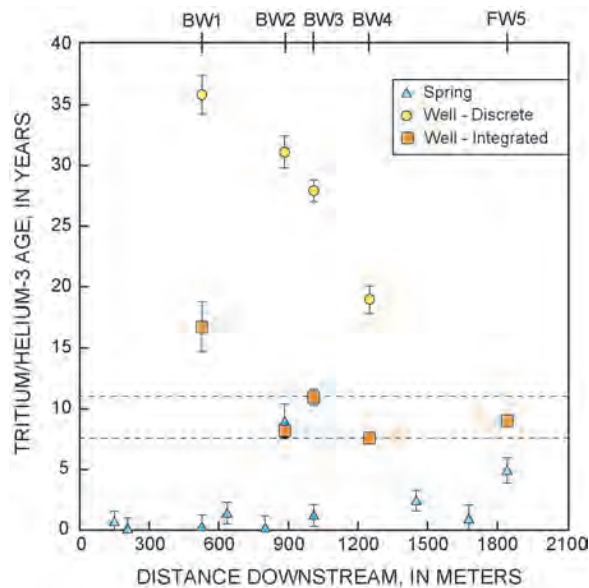

Figure 4. Distance downstream relative to $^3\text{H}/^3\text{He}$ age of groundwater samples from springs and bedrock wells located near the stream. BW1–BW4 and FW5 along top axis indicate well locations. Samples collected from springs are the youngest. Discrete well samples, collected from the bottom of the well screen, are the oldest. Integrated well samples, collected from the entire well screen, are of intermediate age. Dashed lines indicate the relatively narrow zone of variation of mean ages for integrated well samples (BW1 excepted).

Geologic, geophysical, hydrologic, and climatic data were used to construct two numerical groundwater flow models of the site. A finite-difference model of the watershed was constructed using MODFLOW-2000 (Harbaugh et al. 2000) to test the consistency of measured hydrologic data and available climatic information, and to develop a water budget (Figure 5) (Kahn et al. 2007). Modeled groundwater flow rates (based on measured hydraulic conductivities and heads) were consistent with measured stream discharge rates and precipitation. The derived water budget suggests that, under normal climatic conditions, 10–30 percent of precipitation leaves the site in the subsurface, either as underflow beneath the stream or as recharge to the deeper groundwater flow system. A preliminary version of a coupled heat, mass, and fluid-transport finite-element model of the watershed has been constructed using FEFLOW (Diersch 2002). Successful manual calibration to observed heads and temperatures was achieved by assigning hydraulic conductivities similar to those derived from aquifer-test data, decreasing permeability with depth, and applying a recharge rate of 10–20 cm/yr to the bedrock aquifer. The FEFLOW model is consistent with the MODFLOW-2000 model in that groundwater flow velocities under the stream are relatively high, with about 30 percent of bedrock recharge leaving the site as underflow.

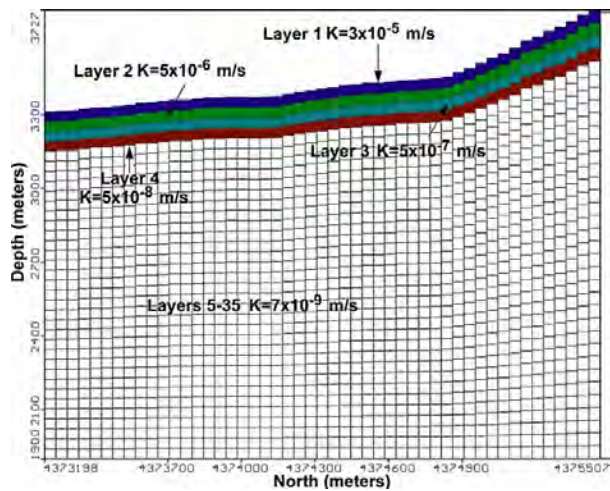

Figure 5. Cross section through three-dimensional MODFLOW groundwater flow model of site from Kahn et al. (2007). Section is roughly parallel to trunk stream. Section shows model mesh and layered hydraulic conductivity distribution, with hydraulic conductivity decreasing with depth.

Acknowledgments

This work was funded by the U.S. Geological Survey Mineral Resources and Mendenhall Postdoctoral Fellowship Programs. We thank Dr. Charles S. Robinson of Mineral Systems, Inc. who donated the deep boreholes in the study area. We also thank Ray Johnson and Kathy Smith for their helpful reviews.

References

- Caine, J.S., A.H. Manning, P.L. Verplanck, D.J. Bove, K.G. Kahn, and S. Ge. 2006. Well construction information, lithologic logs, water-level data, and overview of research in Handcart Gulch, Colorado: An alpine watershed affected by metalliferous hydrothermal alteration. U.S. Geological Survey Open-File Report 2006-1189.
- Diersch, H.J.G. 2002. Interactive, Graphics-Based, Finite Element Simulation System FEFLOW for Modeling Groundwater Flow, Contaminant Mass and Heat Transport Processes. WASY, Berlin.
- Harbaugh, A.W., E.R. Banta, M.C. Hill, and M.G. McDonald. 2000. MODFLOW-2000, the U.S. Geological Survey modular ground-water model: User guide to modularization concepts and the ground-water flow process. U.S. Geological Survey Open-File Report 2000-92.
- Kahn, K.G., S. Ge, J.S. Caine, and A.H. Manning. 2007. Characterization of the shallow groundwater system in an alpine watershed: Handcart Gulch, Colorado. *Hydrogeology Journal* 16(1):103-121.
- Kimball, B.A., R.L. Runkel, K. Walton-Day, and K.E. Bencala. 2002. Assessment of metal loads in watersheds affected by acid mine drainage by using tracer injection synoptic sampling: Cement Creek, Colorado, USA. *Applied Geochemistry* 17:1,183-1,207.
- Manning, A.H., and J.S. Caine. 2007. Groundwater noble gas, age, and temperature signatures in an alpine watershed: Valuable tools in conceptual model development. *Water Resources Research* 43:W04404.
- Verplanck, P.L., A.H. Manning, B.A. Kimball, R.B. McCleskey, R.L. Runkel, J.S. Caine, M. Adams, P.A. Gemery-Hill, and D.L. Fey. 2007. Ground- and surface-water chemistry of Handcart Gulch, Park County, Colorado, 2003-2006. U.S. Geological Survey Open-File Report 2007-1020.
- Verplanck, P.L., D.K. Nordstrom, D.J. Bove, G.S. Plumlee, and R.L. Runkel. In press. Naturally acidic surface and ground waters draining porphyry-related mineralized areas of the southern Rocky Mountains, Colorado and New Mexico. *Applied Geochemistry*.

Water Quality Impacts from Agricultural Land Use in Karst Drainage Basins of SW Kentucky and SW China

Ted W. Baker, Chris G. Groves

Abstract

Karst regions are composed of soluble rock, often limestone, which leads to the formation of fissures, sinkholes, and water flow conduits such as caves. Pollutants in karst waters tend to be quickly directed and concentrated into these subsurface conduits. As a result of this and other factors, water resources are especially sensitive to contamination and pollution in karst areas. Pollutant concentrations going into karst subsurface fluvial systems are often very similar to the concentrations surfacing at outlets such as springs. Areas connected by karst conduit flows must be distinctly determined and special attention should be given to water quality impacts from land-use practices near conduit inputs. The climate which affects a certain karst area can also have different impacts on water resources considerations. In the temperate climate of southwest Kentucky precipitation is mostly evenly distributed throughout the year. Southwest China is affected by a monsoon climate with high precipitation in the spring to summer and drier conditions in other seasons. In the wet season large storm pulses can effectively transport contaminants to water sources resulting in unhealthy loads, while the dry seasons can be particularly severe in karst areas as water quickly drains to the subsurface, making water access a major hardship. Our research focuses on the seasonal differences that the climate of southwest China poses for water quality, including differences in pesticide concentrations between agricultural and residential

areas hydrologically linked by karst conduits. In late 2007 the fluvial connections in a simple karst system near Chongqing were confirmed using dye tracing techniques. The concentration of pesticides in agricultural runoff going into and coming out of the subterranean stream studied were within safe limits. Results supported that there was a close relationship among concentrations of the pesticides glyphosate, chlorothalonil, and atrazine in the input and the output of the system. Taking into account the rapid and direct flows in the karst system, the concentrations of the pesticides found in the output was more similar to the input than would be expected in a surface stream. Analysis of hydrology data of the site will be required before further conclusions can be developed. The research was conducted in the spring and summer of 2007–2008 and funded by the U.S. Agency for International Development.

Keywords: karst, water, pesticides, ELISA

Introduction

Karst water issues

Water connections between areas of different land uses can sometimes be difficult to discern. This is especially true when water sources for an area cannot easily be connected visually to the water flows from surrounding areas, such as in water from springs. Areas that share fluvial connections also share the same water quality. Human land use can affect water quality in springs recharged from a great distance away or presumed disconnected from areas with human impact. Springs in areas characterized by karst geology can be outlets of not just groundwater but also surface water draining from points sometimes located in adjacent surface watersheds (White 1988, Ford and Williams 1989, Lu 2007).

Baker is a graduate student, Hoffman Environmental Research Institute at Western Kentucky University. Groves is a professor with the Department of Geography and Geology at Western Kentucky University, and the Director of the Hoffman Environmental Research Institute and the Center for Cave and Karst Studies. 1906 College Heights Blvd., Bowling Green, KY 42101-1066. Email: ted.baker@wku.edu; chris.groves@wku.edu.

Karst aquifers are those that “contain dissolution-generated conduits that permit the rapid transport of ground water, often in turbulent flow. The conduit system receives localized inputs from sinking surface streams and as storm runoff through sinkholes. The conduit system interconnects with the ground water stored in fractures and in the granular permeability of bedrock” (White 2002, p. 85). Consideration of the flows in karst groundwater systems is necessary for understanding the transport of dissolved compounds in these waters (Quinlan and Ewers 1985).

A detailed understanding of the various flow connections in karst groundwater basins can be difficult to obtain. As mentioned, subsurface conduits can flow under ridges normally used to delineate watershed boundaries. Such a case would require an adjustment in the definition of the effective watershed boundaries (Hao et al. 2006, Croskrey and Groves 2008). Modeling of groundwater flow in karst aquifers has not progressed very much over the last 20 years, though recently water budgets, tracer studies, hydrograph analysis and chemograph analysis have been used for characterizing karst aquifers. Yet, there is still a need to direct attention toward working out processes and mechanisms for contaminant transport in karst aquifers (White 2002, Barfield et al. 2004).

In karst regions water resources are especially sensitive to contamination and pollution (Hao et al. 2006). Normally in nonkarst areas, when precipitation and overland flows pick up contaminants, they can be filtered by soils before entering groundwater storage. These contaminants often come from human uses such as irrigation and industry and can consist of fertilizers, pesticides, toxic bacteria, and industrial wastes. Interaction with soils as water slowly percolates into groundwater aquifers allows for microbes to use or buffer some of these water contaminants through their reactive and metabolic processes (Vesper et al. 2001, Van Eerd et al. 2003, Aquilina et al. 2006). The slow filtering of water into groundwater, long residence times therein and dilution into the vast reserves of aquifers also provides time for harmful bacteria to perish from lack of nutrients and generally dampen the possible toxicity of contaminants (Vesper et al. 2001, Zhang et al. 2006).

Considerations of the soil’s chemical, biochemical, and microbiological properties are important for maintaining soil quality and consequently water quality. There can

be less interaction of water with soils in karst regions as water flows quickly through fissures in the bedrock and are then often directed into concentrated subsurface conduit flows in the rock with relatively low effects from ameliorating reactions (Vesper et al. 2001, Barfield et al. 2004, Aquilina et al. 2006). This can lead to substantial water pollution. This is even more troubling considering that these flows often resurface in springs that are typical drinking water sources (White 1988, Ford and Williams 1989, Zhang et al. 2006).

Pollutants in karst waters tend to move rapidly through conduits. In low-permeability zones with rapid flows through conduits, the pollutant concentrations going into subsurface fluvial systems are very similar to the pollutant concentrations coming out (Vesper et al. 2001, Groves et al. 2002). If there is little or no interaction with sediment along the conduit length and the flow is slower, pollutants tend to become more concentrated in the water, as reflected in the discharge. In contrast to surface water flows, karst subsurface flows see little to no effect on contaminant loads from plant interaction and uptake, photolytic effects, and processes requiring more oxygen availability (Van Eerd et al. 2003). Also, in systems with small conduits a restriction of the flow can occur more easily during high water input periods, which can lead to backflooding and a return of contaminants in the reverse flow direction, possibly even to the source (Vaute et al. 1997).

General water quality of Kentucky and China

More than a million people in Kentucky use public water supplies that use groundwater, and around half a million people there use groundwater as a private water source. Half of Kentucky’s groundwater is estimated to be contaminated by bacteria. Most karst springs in Kentucky have been abandoned as municipal water sources because of groundwater contamination, but 11 percent of Kentucky karst springs are still used as rural water sources by local residents. Yet, abandoned or not, springs still often drain to streams used as water sources. Estimates of the people using surface water fed from groundwater sources are not available and may be too complex to properly establish. The true extent of the problem is difficult to determine once groundwater resources have been contaminated (Taraba et al. 1997, Croskrey and Groves 2008).

The southwest (SW) Kentucky karst region has been studied extensively and includes the Mammoth Cave

system, the longest known cave in the world, and the Pennyroyal Sinkhole plain, well known for its high concentration of sinkholes covering a primarily agricultural area. Water quality is a principal focus in the area, especially in recent years. The difference in climate creates a major difference in the karst water considerations of SW Kentucky and those of SW China (Shuster and White 1971, Anthony et al. 2003, Liu et al. 2007).

Water acquisition and quality in China are major hindrances to sustainable development throughout the country (World Bank 2003). Almost 700 million people in China do not have access to safe water. They often consume water that contains excess of what is considered the maximum permissible levels for fecal coliform bacteria, an indicator of microbes that spread a variety of illnesses (Turner 2006). Each year one-third of industrial wastewater and two-thirds of household sewage is returned to water resources untreated. More than 75 percent of the rivers flowing through Chinese cities are unsuitable for drinking or fishing. Almost half of China's surface rivers are so polluted that they are not even suitable for agriculture or industry (Turner 2006). Water scarcity concerns have also led to the use of industrial wastewater to irrigate farmland. In urban areas 70 percent of drinking water comes from groundwater sources, 50–90 percent of which is contaminated by agricultural runoff, industrial and municipal wastewater, and in some municipalities even toxic mine tailings (Hamburger 2005, Turner 2006, Turner and Otsuka 2006, Guo and Ma 2007, Ministry of Water Resources 2007).

The severity of China's water problems and particular issues of concern vary depending on the local climate and economy, as well as the character of each geographic region. Karst areas here pose unique problems in dealing with water issues. Approximately one-third of China's terrain is made up of karst regions containing some of the most well developed karst landforms observed on earth. The southern karst region covers approximately 500,000 km² over eight provinces. Of the 80 million Chinese who live in the SW China karst region, about 8 million live below the area's poverty level (Groves 2007). A monsoonal climate affects most of this area with most annual precipitation falling May–August, the typical summer monsoon season. Very dry conditions are common through the rest of the year (World Resources Institute 1998). The dry season is especially severe in karst

regions as surface water is quickly directed into subsurface flows, making it hard to access for populations with very limited means. Therefore, poor rural residents can spend a large portion of their time collecting water in the dry months, traveling long distances over difficult terrain (Groves 2007).

The monsoon climate of SW China provides important additional considerations of the controls of contaminant transport in affected areas. High pulses of rainfall and runoff can lead to a corresponding pulse in some dissolved ions. Sulfate and nitrate concentrations have increased significantly in past two decades in SW China and they peak in the rainy season (Chena et al. 2005). Anthropogenic inputs have major effects on water chemistry. Nitrate and chlorine are two ions affected by this and are the main contributors to groundwater pollution in SW China (Guo et al. 2007). Sewage effluent is the primary source of nitrates in urban areas, while chemical fertilizers and domestic animal wastes are the primary source in rural areas (Lu 2007).

In agricultural areas the main pollutants are fertilizers and pesticides, as well as fecal coliform and more harmful bacteria in areas of high animal use and poor sewage treatment (Aharonson et al. 1987). Because nitrates are very soluble, they do not readily bind to soils and have a high potential to move into groundwater. Since they do not evaporate, nitrates can remain in water until consumed by plants or other organisms—which happens much less in subsurface rivers than surface rivers (Van Eerd et al. 2003). When comparing nitrate in groundwater and surface water, a higher content of nitrate is found in groundwater during the summer and winter seasons. This suggests that denitrification is not a significant factor in karst groundwater systems. Therefore, karst groundwater systems do not easily recover when they are contaminated with nitrates (Almasri and Kaluarachchi 2007).

China is the most populous country in the world, although it is the fourth largest geographically and only 10 percent of it is arable land (Turner 2006). Due to a need to utilize the land intensively to feed its people, China is also one of the largest producers and consumers of pesticides (Yang 2007). China produces many of its own pesticides and, although recent events have spurred steps toward further regulation, they have comparatively lax regulations and monitoring of pesticide use. As a result pesticides are often applied in

excess and not handled properly (Reuters 2007, Yang 2007). Therefore, pesticide contamination in water resources is a concern in China. This contamination can be difficult to ameliorate and can lead to significant human health and environmental concerns. These include severe impacts to ecosystems and persistence in soils, as with DDT and other organochlorines used in the past, or carcinogenic properties and dangers of acute and chronic toxicity, as with some organophosphates used in the present (Wang et al. 2006, Reuters 2007, Yang 2007).

The use of land for agriculture in China has increased significantly over the past 50 years (Hajahhasi et al. 1997, Zheng et al. 2005, Jiang et al. 2007). After decades of high pesticide application the environment has been degraded and enormous economic losses have resulted: “Many of the pesticides used are highly toxic, resulting in tens of thousands of users being injured or dying every year. Consequently, it is essential to control pesticide use and at the same time develop China’s agricultural economy” (Xu et al. 2003, p. 78).

Study Area

The United States Agency for International Development (USAID) funded a grant to develop cooperative efforts between the United States and China. A primary component of this grant is to address issues of water access and quality in rural SW China. As part of this effort we examined the water quality in a watershed of interest in this area, specifically focusing on pesticide levels in water sources. The particular watershed of interest is Qingmuguan (QMG), as it supplies water for the city of Qingmuguan at the southern end of the basin. It is located 25 km northwest of the major city of Chongqing. The watershed is approximately 13.4 km² stretching 11.2 km long and 1.1 km wide (Figure 1). The initial question we sought to address was whether the pesticide levels exiting the groundwater basin posed any human concerns and under what different hydrologic conditions the levels could be a concern.

The northern section of the basin contains the main agricultural valley. Here, as in other areas of the basin, rice is the primary crop, with corn and other crops grown on the margins of the valley floor. Other areas of agriculture are scattered throughout the basin, including significant fields of tomatoes. A variety of other small crops are grown for personal use within the basin. Still,

where water resources are concerned, it is the stream draining the rice fields and this northern agricultural area that is our primary interest (Nakanoa et al. 2004).

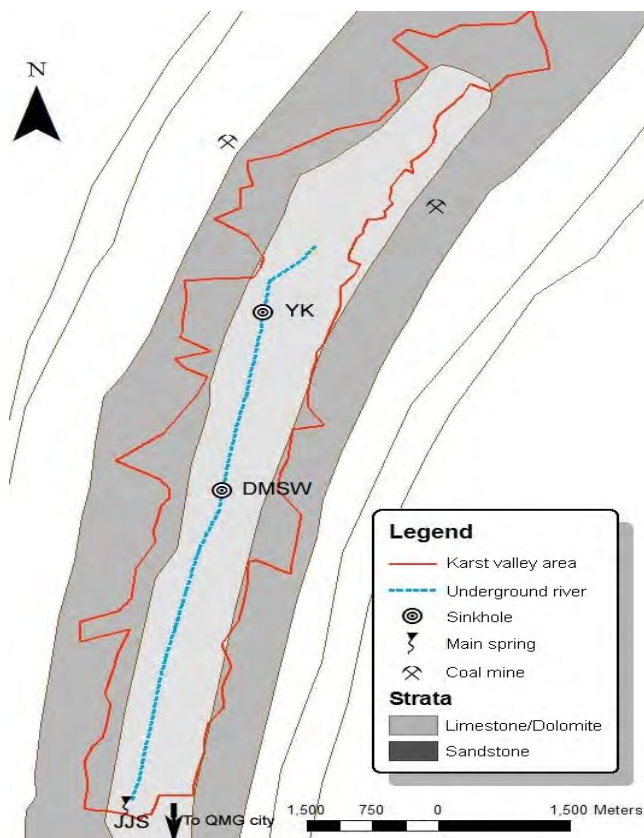

Figure 1. The Qingmuguan (QMG) groundwater basin. The Yankou sinkhole (YK) drains an agricultural valley, and the Damushuiwo sinkhole (DMSW) drains an ephemeral lake to Jiangjia spring (JJS). The basin lies in a mountainous area formed by an anticline with valleys at the center of the basin consisting of limestone, while the ridges on the margins are sandstone separated by a coal layer that has been mined within the last 20 years

The valley is in the middle of a series of anticlines and synclines in the landscape. It is situated in an anticline that has been eroded into the formation of a few valleys and hills in between two major ridges. This also means that it sits at a higher elevation than the surrounding area, a valley in the mountains. The center low part of the basin is where the limestone is found. The basin is lined by sandstone layers in the ridges surrounding it. The limestone and sandstone are separated by a layer of coal. There is a noticeable vegetation difference between the limestone and sandstone. Bamboo and thick shrubs and undergrowth are found lower on the hills, but stands of pine with ferns in the undergrowth

are observed when crossing to the sandstone. Nearly all flat areas in QMG and some slopes are cultivated. The coal seams in the area have been mined significantly, and a few limestone quarries are in the basin, which leave steep sandstone slopes exposed to erosion into the valleys (Hajahhasi et al. 1997, Zheng et al. 2005).

Silicates from erosion runoff coming from these slopes and entering sinkholes can be an indicator of surface sediment transport in the QMG subterranean river system (QSRS). During two storm events in April 2008, the flux of soil erosion was calculated at approximately 9.7 tons, not including the sediment less than 0.45 μm in diameter and the bed-load material (Figure 2). Bacteria, pesticides, and other potential pollutants are adsorbed on sediment, which contributes to water quality problems and can lead to human health problems (Malmon et al. 2002, Hilscherova et al. 2007). There are few water treatment facilities in rural areas of China including in the QMG area.

Although the basic concerns dealing with water quality in SW Kentucky and SW China karst areas are the same, the conditions are quite different in a number of respects. These conditions include the soils and geology, as well as the vast climate differences. The

limestone strata in QMG are from the Triassic period of the Mesozoic Era that extends from about 250 to 200 million years ago. Southwest Kentucky consists mainly of strata dating from the Mississippian epoch extending from about 360 to 325 million years ago and is part of the Carboniferous period of the Paleozoic Era. The sandstone in Kentucky is also from the younger Pennsylvanian epoch of the Carboniferous period, while the sandstone in QMG is from the Jurassic period (Liu et al. 2004). Yet, even with different geologic histories, the processes involved in the contents of the karst waters should not be significantly different. For this study, the main differences of interest between SW Kentucky and SW China are the contrasts of climate, topography, hydrology, and the crops grown, along with the treatments used on them.

Methods

Preliminary data collection on the water resources conditions in the QMG began in July 2007. Assessment of the conditions of the area began with the extensive study of map resources on the groundwater basin. This was followed by a karst hydrogeologic inventory that involved hiking throughout the watershed and

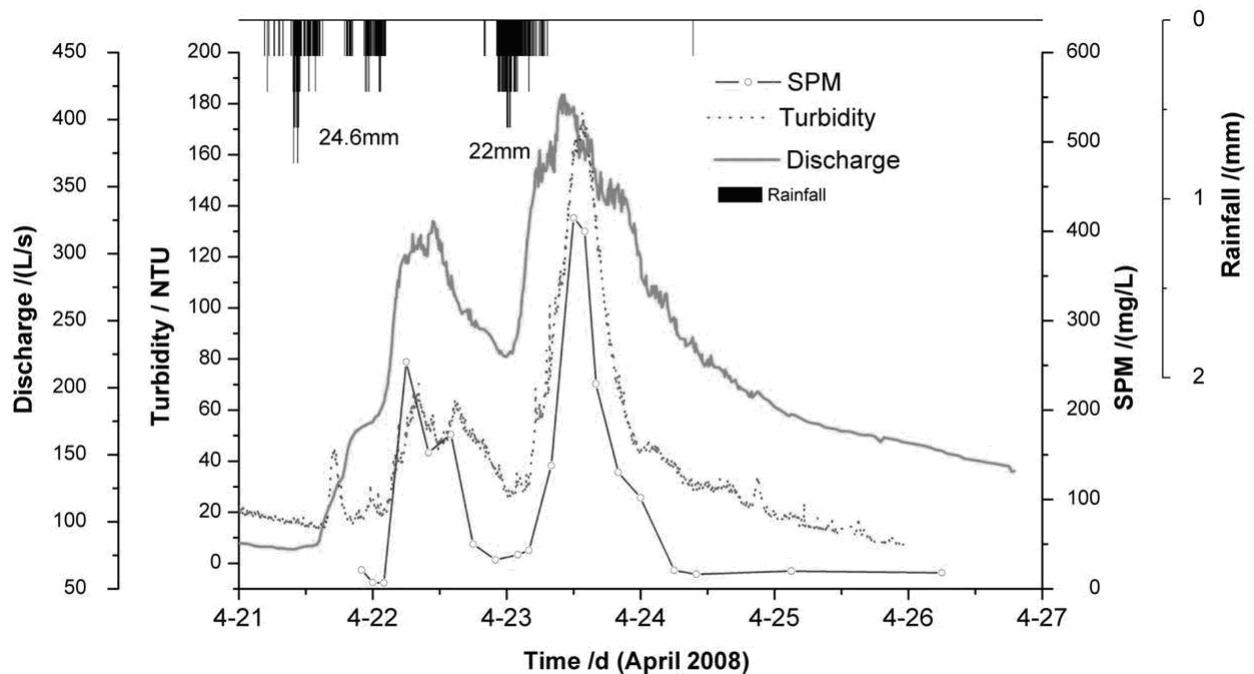

Figure 2. Data from two storm events at JJS in QMG show the relationship between discharge, turbidity, and suspended particulate matter (SPM) during storm events in the QMG subterranean river system (QSRS). The strong response and high levels can be associated with water contamination concerns (adapted from Yang, in press)

cataloging the karst features contained in the study area. GPS locations and elevations were recorded for each of the features inventoried. If water was present in the feature, the temperature, pH, specific conductance, and an estimate of the discharge were recorded. Dissolved oxygen measurements were also recorded at some sites.

Water samples were collected at the sinking stream and the main spring, along with a number of other sites of interest within the groundwater basin. These were brought back to Western Kentucky University (WKU) on ice within two days and tested for anions, cations, metals, total organic carbon, chemical oxygen demand, turbidity and atrazine. The results showed standard ion concentrations for a karst groundwater basin. Yet, nitrate in the spring was 15.41 mg/L, which is above the U.S. Environmental Protection Agency (USEPA) 10 mg/L limit of concern for drinking water. Additionally, iron was rather high, but high iron in water supplies is not considered a health hazard as much as an aesthetic problem. Results also show atrazine, used in the upper watershed, with 0.6 ppb reported in the runoff draining the northern agricultural valley, which is below the USEPA recommended safe limit for drinking water of 3 ppb.

Two dye traces were also conducted to determine the connections between karst fluvial features in the basin. This was done after many days of assessing and re-assessing the flow conditions in the area. Charcoal receptors were placed at six karst water features of interest within the watershed. Background receptors were obtained prior to injection of dye. Uranine (Fluorescein) dye, 802.4 grams, was injected at Yankou sinkhole (YK) on August 1, 2007. The receptors were changed on days 2, 5, and 9. The receptors were kept on ice and returned to the Crawford Hydrology Laboratory at WKU for spectrofluorophotometer analysis.

Additionally, 200 grams of Uranine was injected at Damushuiwo (DMSW) swallet on September 14, 2007, with data collected through September 23. In addition to data from the charcoal receptors from the first trace, continuous dye levels were recorded at Jiangjia spring (JJS) for both of the dye traces. This was done through the use of a flow-through field fluorometer, a dye receptor instrument developed by Swiss research partners, and allowed for a more accurate determination of the time of the initial dye recovery and a calculation of the percent of the dye recovered. During the YK injection, 93.4 percent of the Uranine arrived at JJS 33.3 hours after injection. The flow conditions were

lower during the DMSW injection, and the dye arrived about 42 hours after injection.

Additional work of assessing the area was also done by developing more detailed geologic cross-sections than available at the time. These were conducted by hiking the length of designated cross-sections and taking measurements of any outcrops with a Brunton compass. An initial list of the pesticides used in the area was also generated by conducting interviews with the local farmers and the retrieval of empty pesticide packages from QMG. These packages are typically discarded at whatever location in the field the product happened to be mixed, usually near a water source. This list is shown in Table 1, but it likely represents the minority of pesticide concentration going into the QSRS system.

Table 1. Data on pesticides used in QMG obtained through interviews are listed in italics. Other pesticides listed were identified as being in use in the area via the collection of pesticide packages found on the ground in the basin. Pesticide concentrations tested in water samples are listed in bold (EXTOXNET 2008, Pesticide Action Network North America 2008).

Pesticides	Use ^a type	Groundwater contaminant	Acute ^b toxicity	Carcin- ogen ^c	Other ^d health
<i>Atrazine</i>	1	Yes	1	2	1
<i>Glyphosate</i>	1	Low	1	1	--
<i>Glufosinate</i>	1	--	1	--	1
<i>Metsulfuron-methyl</i>	1	Potential	1	1	--
<i>Dimethoate</i>	2	Potential	2	2	1,2,3
<i>Thiosultap disodium</i>	2	--	--	--	--
<i>Isocarbophos</i>	2	--	--	--	--
Chlorpyrifos	2	Conditional	2	1	1,2
Avermectin	2	Low	3	1	3
Cypermethrin beta	2	Low	1-2	2	1
Emamectin benzoate	2	Low	3	1	--
Hexaflumuron	2	--	1	1	--
Carbendazim sulfur	3	No	1	2	1
Chlorothalonil	3	Potential	3	3	--
Cymoxanil	3	--	1	1	--
Fosetyl aluminum	3	Potential	3	1	--
Mancozeb	3	Low	0	3	1,3,4
Mefenoxam	3	--	3	1	--
Procymidone	3	--	0	3	1
Pyrimethanil	3	--	0	2	1
Streptomycin sulfate	3	--	2	--	3
Thiram	3	Conditional	1	1	1,3,4
Ziram	3	Conditional	1	2	1,3,4
Metaldehyde	4	Potential	2	2	--

a. 1=Insecticide, 2=Fungicide, 3=Herbicide, 4=Molluscicide
b. 0=Not toxic, 1=Slightly toxic, 2=Moderately toxic, 3=Highly toxic
c. 1=Unlikely carcinogen, 2=Possible carcinogen, 3=Probable carcinogen
d. 1= Suspected endocrine disruptor, 2=Neurotoxin (Cholinesterase inhibitor), 3=Developmental toxin, 4=Reproductive toxin

Additionally, over the course of interviews with 4–5 farmers in the area, 7–8 pesticides were cited as the most prominently used in QMG. The majority of

interviews were conducted in the YK valley. The most common insecticide mentioned was dimethoate, and the most common herbicide was glyphosate. Based on potential health concerns and potential for groundwater contamination, a number of pesticides were considered for analysis in QMG water resources (Table 1). Unfortunately, only methods for testing glyphosate, chlorothalonil, atrazine, and some samples for chlorpyrifos were feasible for analysis due to testing resources available at the time. Glyphosate is very widely used in QMG and worldwide but is not considered a great concern for groundwater contamination or human health. Chlorothalonil is considered a possible concern for groundwater contamination and human health effects but is not widely used worldwide, while the extent of use in QMG is unknown. The residents claimed they use little to no pesticides on their corn crops in recent seasons, yet atrazine is known to be quite persistent in water resources. Our preliminary testing indicated its presence, so we decided to test for it as well. Chlorpyrifos is not as great a concern for groundwater contamination in alkaline water as with more acidic to neutral water; it has some possible health effects (Tables 1, 2). It was not cited as used in QMG until June 2008, so it was only tested for in July (EXTOXNET 2008, Pesticide Action Network North America 2008).

During the summer of 2008, water samples were collected from YK and JJS June 4–July 28 using U.S. Geological Survey (USGS) protocols (U.S. Geological Survey 2006). The water samples were collected 2–3 times per week in 40 ml volatile organic compound amber glass bottles and usually tested within 24–48 hrs of their collection, but within 1–2 weeks in all cases (Quinlan and Alexander 1987). They were tested for each specific pesticide using highly sensitive quantitative test kits produced for this study by Strategic Diagnostic Inc. and Abraxis. The methods used by these kits are Enzyme-Linked Immuno-Sorbent Assay (ELISA) tests. They are normally magnetic particle-based competitive ELISA tests. The analysis of the assay results were conducted using a Shimadzu UV-2450 spectrophotometer at 450 nm by using a micropipettor to transfer the assay solutions to 1 mL cuvettes acquired for use in this particular spectrophotometer. The ELISA kits needed for the analytical instruments available used test tubes, as opposed to microtiter plate kits. ELISA kits of either kind were not available for most of the pesticides of

interest used in the QMG study area. The pesticides mentioned, as well as procymidon, were the only ones with kits available for use with the accessible analytical equipment.

Data loggers were established at YK and JJS recording stage, temperature, pH, specific conductance, and at JJS the nitrate concentration every 15 min. There were three stations throughout the basin recording precipitation. Unfortunately, those results were not yet available for this analysis. Analysis of pesticide loads and comparisons based on these conditions will be reported in 2009.

Results and Discussion

The primary feature of interest is JJS because it affects the quality of one of the water supplies for the city of Qingmuguan and is a source of drinking water for approximately 500 local residents. Based on the dye traces conducted in the fall of 2007, and after consideration of the nature of the items in the hydrogeologic inventory, we determined that the primary features in QMG that supply flows to JJS were YK and, during large storm events, DMSW. During large storm events the valley at DMSW floods and then drains rapidly into the swallet connected to JJS. Consequently, there is extra-high discharge observed at JJS until this valley is drained. Because this valley floods often in the rainy season, no crops are usually grown in it. However, corn is grown on the slopes surrounding the valley, which may allow pesticides to runoff to the swallet.

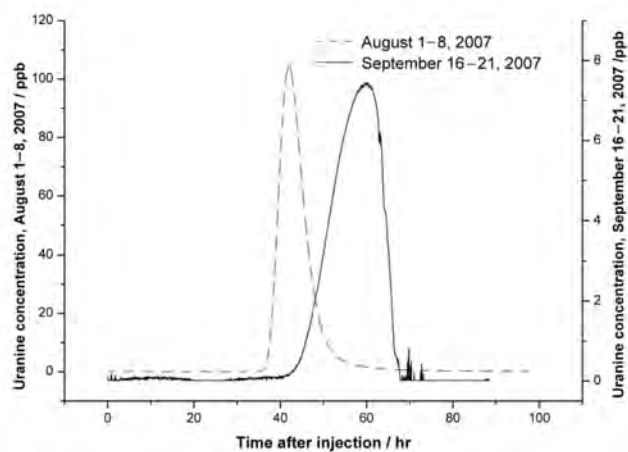

Figure 3. The breakthrough curve showing the pulse of dye arriving at JJS after injection at YK in August and DMSW in September 2007 (adapted from Yang, in press).

In the case of both dye traces, the single strong peak of breakthrough curve (Figure 3) suggests that a well-developed and connected conduit system exists for underground flow in a direct conduit path between the locations in the QMG subterranean river system (QSRS). The results also suggest that the transport time is rapid, especially during higher flows.

The results of our detailed cross-section efforts indicate the likely path of the QRSR flow, as it normally follows bedding planes. This may also allow us to understand which sections of the basin most strongly affect QRSR surface water and sediment input.

There are also a number of small springs draining into different small valleys in the QMG groundwater basin from the adjacent slopes. These are likely fed from runoff from the steep sandstone slopes above. We documented sinkholes in these valleys as well. During storm events it is likely that these springs, along with other runoff sources, also drain into these sinkholes, which may then flow into the QRSR. If this were so, it is not likely there would be any significant input coming

from these valleys except after large storm events. In this case there would be a strong dilution effect on the movement of contaminants into QRSR from these sources. Also, none of the flow paths of these springs passed through any significant agricultural areas, so there may not be a significant load of contaminants coming into the QRSR from these sources either.

We suspected that the amount of contaminants found in YK and DMSW and the amount found in JJS would not be significantly different based on previous related studies that have been conducted in other locations (Vaute et al. 1997, Lang et al. 2006, Liu et al. 2007, Guo et al. 2007).

The potential for groundwater contamination and persistence of each compound in the environment depends on their water solubility, soil adsorption, potential for breakdown in water based on hydrolysis half-life of the compound, and potential for breakdown in soil based on aerobic and anaerobic soil half-life of the compound (Table 2).

Table 2. Details of pesticides sampled in QMG, June 4–July 28, 2008 (EXTOXNET 2008, Pesticide Action Network North America 2008).

<p>Chlorothalonil—Fungicide (organochlorine)</p> <ul style="list-style-type: none"> • Low solubility = 0.6 mg/L at 25°C • High adsorbance coefficient = 1380 • In very basic water (pH 9.0) 65% degrades within 10 weeks • Soil half-life is 1–3 months • Degrades faster with increased soil moisture and (or) higher temperature • High binding and low mobility in silty soils • Low binding, moderate mobility in sandy soils • High acute toxicity and highly toxic to fish • Possible carcinogen • Potential groundwater contaminant • Health Advisory Level (HAL) = 1.5 ppb 	<p>Atrazine—Herbicide (triazine), broadleaf/grasses</p> <ul style="list-style-type: none"> • Most used pesticide in the U.S., favored for corn • Claimed not to be used currently in QMG • Low to moderate solubility = 28 mg/L at 20°C • Low to moderate adsorbance coefficient = 100 • Half life = 60 to >100 days • High hydrolysis breakdown • High breakdown in acidic and basic conditions, low breakdown in neutral • Prominent groundwater contaminant • Slight acute toxicity • Debated as a carcinogen • Suspected endocrine disruptor • Maximum Contaminant Level (MCL) = 3 ppb
<p>Glyphosate—Herbicide</p> <ul style="list-style-type: none"> • Very common nonselective broad-spectrum product (Roundup) • High solubility = 12,000 mg/L at 25°C • Very high adsorbance, even with low organic matter and clays = 24,000 (estimated) • Moderately persistence in soils, half-life ~47 days, subject to microbial breakdown • Low potential for runoff (except colloidal) • Low to slight acute toxicity • Debated as a possible endocrine disruptor • MCL = 700 ppb 	<p>Chlorpyrifos—Insecticide (organophosphate)</p> <ul style="list-style-type: none"> • Low solubility = 2 mg/L at 25°C • High adsorbance = coefficient 6070 • Moderate soil persistence = 2 weeks to 1 year or more, depending on soil type, climate, etc. • High volatilization • High hydrolysis, especially in alkaline waters • Low persistence in high pH conditions • Moderate acute toxicity • Suspected endocrine disruptor • Significant neurotoxin (Cholinesterase inhibitor) • HAL = 21 ppb

Judging from discharge observations, dye trace results, and other data collected by colleagues, there are high pulses of water traveling through a main conduit in the QSRS at a rapid rate. As discharge rises within a few hours of initial storm events, specific conductance and CO² partial pressure promptly go up in response and pH goes down. This indicates surface runoff coming into the spring as the water interacts with the silicate slopes. Water temperature gets continuously lower over time, especially over repeated events. This may suggest that there is significant recharge to groundwater sources connected to the spring (Li et al. 2005; Yang, in press).

Nitrate levels at JJS were high in bimonthly samples March–July 2007, never dropping below 20 ppm and reaching as high as 50 ppm. Levels were lower in YK, usually less than 3 ppm (He Qiufang, 2007, Southwest University of China, unpublished data). The USEPA MCL is 10 ppm (U.S. Environmental Protection Agency 2003). High nitrate levels are largely influenced by inputs of irrigation water in agricultural areas (Almasri and Kaluarachchi 2007). The high nitrate levels at JJS suggest that groundwater is not its main source; it seems its other significant agricultural water inputs in QMG.

The year 2007 was very wet with a 100-year flood in the area that season. JJS could have also received a strong pulse from storm events 1–2 days prior to some of the sampling, which could explain some of the high levels. Data logger records will need to be obtained to address this. Alternatively, it may have come from DMSW since it was often flooded during the season, but it is likely that there are a few other discreet inputs to the QSRS system near agricultural field sites in QMG that we did not locate. The presence of atrazine at the YK but not at JJS could indicate processes are breaking down pesticides along the length of the underground river. Corn is grown most prominently in the YK valley, so it is not likely that much atrazine is used in the areas of additional agricultural water input throughout the basin. So, if the discharge is much higher at JJS than at YK, which suggests more input from throughout the basin, then the concentration would be too dilute to quantify. Yet, considering that the QSRS flows through a large conduit, it may be during the initial runoff pulse YK to JJS that pesticide loads could be a concern.

The year 2008 was unusually dry for QMG. There was only one major storm event (June 15) during the sampling period. There were a few other very small rain

events, including on July 17, but none that likely greatly impacted the discharge at JJS. As mentioned, rainfall and discharge data are not available at the present time. Still, the ELISA test results show a definite response in pesticide concentrations in water samples at both locations around June 15 and other smaller storm events. Otherwise, during base flow conditions, there was somewhat random fluctuation in pesticide concentrations in the water at the locations. Yet, even under low-flow conditions, the concentrations of the pesticides found at JJS were similar to those found at YK and reflected similar changes in the levels observed over the 2008 summer season.

Conclusions

The pesticide levels observed were mostly taken during low-flow, baseline conditions. There was still a distinct relationship seen between the concentrations of pesticides in YK and JJS. There were not many detectable levels of the pesticides found in DMSW, yet there was only one storm event large enough to flood the valley and send a considerable amount of water into the sinkhole over a short period. It is difficult to claim that there was a significant amount of more pesticides found in JJS compared to YK than would be normally observed in a surface stream. This is especially true since the actual loads cannot be known until discharge measurements are available. Still, all pesticide concentrations in the samples taken were well below the maximum contaminant levels (MCLs) and health advisory levels (HALs) used in the United States (U.S. Environmental Protection Agency 2003). Regardless of load calculations, in this case under base flow conditions, there is little call for concern over high levels of pesticides coming out of JJS, even though there are excessive nitrates found in JJS during high discharge events.

Still, levels are expected to be much higher during application periods and significant rain events. Karst systems are sensitive to water pollution with lower mitigating effects, especially in the well-developed systems of SW China (Yuan et al. 1990). Discharge observations, the dye traces, water chemistry, and sediment data all indicate that a well-developed conduit connects the YK and JJS and that DMSW drains directly into the QSRS. Based on this information and additional QMG water data collected in 2007, perhaps other inferences can be made about possible high pesticide loads in JJS.

Southwest University of China researchers began detailed investigations into the groundwater hydrochemistry and microbe activity in the QMG area in early 2007. As mentioned earlier, water and soil samples were taken every two weeks from March–July of 2007. Rainfall and discharge data are not available from this time, but data from September 2007 and April 2008 indicate that sudden shifts in ion concentrations and specific conductance shortly follow an increase in rain (Yang, in press). This should lead to an increase in soluble ions in runoff and a decrease in ions dominant during base flow conditions as they become diluted by the higher flows (Liu et al. 2004, Nakano et al. 2004).

The data from early 2007 show an increase in nitrate coinciding with a decrease in calcium and bicarbonate (He Qiu-fang, 2007, Southwest University of China, unpublished data). This indicates that during initial high flow pulses in spring when fertilizers are being applied, the nitrates are easily transported to JJS, leading to high concentrations in the spring (Jiang 2006). It then follows that other compounds such as pesticides that are normally applied during the springtime can become concentrated at JJS in high flows. Turbidity is also high during these pulses, as seen in Figure 2 (Malmon et al. 2002; Yang, in press). So, for example, even though glyphosate is quickly adsorbed to soils, during such events it could easily be transported to JJS at levels close to the same as that of application concentrations at YK. This would hold true whether it was dissolved in the discharge or, almost as significantly, adsorbed to the sediment in the water column. Glyphosate is not a significant human health threat, but this scenario just as easily applies to pesticides or other compounds with similar properties that may be a health concern. This is especially true since the sediments are not filtered by any water treatment facilities or other means in QMG before human consumption.

In considering these factors there is still cause for concern over possible pollution of the JJS water during the early monsoon season (Chena et al. 2005, Liu et al. 2007). High nitrate likely comes from fertilizers used by local farmers. If the nitrate is so high, then pesticides applied during this time that can readily be transported in surface water can also contaminate the water. Still, there could be less cause for concern for pesticide contamination in some cases. Whereas all agricultural areas likely apply chemical fertilizers, only certain areas or farmers apply certain pesticides. This could keep any one product from reaching too high of a load, although

it would not rule out possible compounding pesticide combinations. There is also the factor of dilution from other nonagricultural inputs along the length of the basin. But, for example, if everyone is applying glyphosate to clear out grasses for rice fields, then given the nature of the karst conduit system, high levels of glyphosate or many other pesticides could certainly become concentrated at dangerous levels in JJS (Li and Zhang 1999, Li et al. 2002).

Microbial data are not yet available for QMG, but the water chemistry results show that there were strong pulses of water going through the system. More contaminants can be transported by these flows and would likely be represented in the initial flow increase as contaminants are initially dissolved into runoff and transported through the system. Also, the higher amounts of sediment in the water in these conditions could encourage higher microbial interaction with compounds adsorbed to these sediments and a reduction in contaminant loads (Zhang et al. 2006). However, the high turbulent flows could also suggest that there could be low microbial interaction due to the harsh environment. This could also lead to a lower amount of sediment remaining in QSRS as it is flushed out by the high flows. Hence, the conduit system may not retain effective amounts of sediment with its associated nutrients to support comparatively high microbial interactions with the contents of the water (Hilscherova et al. 2007). If there was low water interaction with microbial processes in subsurface conduits following high flow events, then there should not be as much biological breakdown of contaminants entering the system. Microbial processes are a major factor in the breakdown of contaminants (Van Eerd et al. 2003). Therefore, this condition could be a factor leading to a diminished capacity for natural processes to ameliorate contaminant problems in affected karst systems.

No researchers or agencies are known to have monitored the pesticide levels in the QMG water prior to this study. Our academic partners at the Southwest University of China have recently expanded their laboratories with more analytical instruments to accurately test for a number of geochemical parameters and pesticides. The Chinese government has shown increased interest in recent years in lowering national pollution and raising the quality of life for all of their people (World Resources Institute 1998, Turner and Otsuka 2006, U.S. Embassy in Beijing, China 2006, Reuters 2007, Xinhua News Agency 2007). Research

such as this will provide support for these efforts to continue. Collaboration with our Chinese colleagues on karst scientific methods has brought the closer attention of local researchers to the special concerns dealing with impacts from excessive agricultural chemical usage in karst regions. During the summer of 2008, visiting specialists from another collaborating university in China also came to our field site to collect samples for a broad-spectrum analysis of the pesticides found in a number of water resources in QMG. Recent efforts by local researchers to focus on land-use issues in China and to expand the scope of science being conducted in the SW China karst region have been quite successful.

Acknowledgments

The authors would like to thank Yang Pingheng, Peng Jia, He Qiufang, Dong Wuxu, Jiang Yongjun, Yuan Daoxian, Brian Ham, Chelsea Durfey, Lee Anne Bledsoe, and Priscilla Baker for help with this project.

References

- Aharonson, N., S.Z. Cohen, N. Drescher, T.J. Gish, S. Gorbach, P.C. Kearney, S. Otto, T.R. Roberts, and J.W. Vonk. 1987. Potential contamination of ground water by pesticides. *Pure and Applied Chemistry* 59(10):1,419–1,446.
- Almasri, M., and J. Kaluarachchi. 2007. Modeling nitrate contamination of groundwater in agricultural watersheds. *Journal of Hydrology* 343:211–229.
- Anthony, D., C. Groves, and J. Meiman. 2003. Preliminary investigations of seasonal changes in the geochemical evolution of the Logdson River, Mammoth Cave, Kentucky. *Speleogenesis and Evolution of Karst Aquifers* 1(4):1–6. [online] URL: <http://www.speleogenesis.info/archive/publication.php?PubID=3257&Type=publication>. Accessed 30 May 2008.
- Aquilina, L., B. Ladouche, and N. Dörfliger. 2006. Water storage and transfer in the epikarst of karstic systems during high flow periods. *Journal of Hydrology* 327:472–485.
- Barfield, B., G. Felton, E. Stevens, and M. McCann. 2004. A simple model of karst spring flow using modified NRCS procedures. *Journal of Hydrology* 287:34–48.
- Chena, M., D. Pollard, and E. Barron. 2005. Hydrologic processes in China and their association with summer precipitation anomalies. *Journal of Hydrology* 301:14–28.
- Croskrey, A., and C.G. Groves. 2008. Groundwater sensitivity mapping in Kentucky using GIS and digitally vectorized geologic quadrangles. *Environmental Geology* 54:913–920.
- EXTOXNET. [2008]. ETOXNET: The Extension Toxicology Network. University of California–Davis, Oregon State University, Michigan State University, Cornell University, University of Idaho. [online] URL: <http://extoxnet.orst.edu/ghindex.html>. Accessed 5 March 2008.
- Ford, D.C., and P.W. Williams. 1989. *Karst Geomorphology and Hydrology*. Unwin Hyman Ltd. Winchester, MA, pp 120-135.
- Groves, C.G. 2007. Water resource challenges in karst regions of southwest China. *China Environment Series* 9:139–148.
- Groves, C.G., J. Meiman, J. Despain, Z. Liu, and D.X. Yuan. 2002. Karst aquifers as atmospheric carbon sinks: An evolving global network of research sites. In E.L. Kunlansky, ed., *U.S. Geological Survey Karst Interest Group Proceedings*, Shepherdstown, WV, August 20–22, 2002, pp. 32–39. U.S. Geological Survey Water-Resources Investigations Report 02-4174.
- Guo, C., and T. Ma. 2007. The optimum allocation of water resources in the karst rock areas of Southwest China. In *Groundwater: Present Status and Future Task: Full papers of the 34th Congress of the International Association of Hydrogeologists*, Beijing, 9–13 October 2006. Ministry of Land and Water Resources, China Geological Survey, Beijing. [online] URL: http://old.cgs.gov.cn/zt_more/34/zhaiyao/html/05/525.htm. Accessed 3 January 2008.
- Guo, F., G. Jiang, and D.X. Yuan. 2007. Major ions in typical subterranean rivers and their anthropogenic impacts in southwest karst areas, China. *Environmental Geology* 65:664–672.
- Hajahhasi, M., A. Jalalian, and H. Karimzadeh. 1997. Deforestation effect on soil physical and chemical properties, Lordegan, Iran. *Plant and Soil* 190:301–308.

- Hamburger, J. 2005. Pesticides in China: A growing threat to food safety, public health, and the environment. *China Environment Series* 5:29-44.
- Hao, Y., T. Yeh, C. Hu, Y. Wang, and X. Li. 2006. Karst groundwater management by defining protection zones based on regional geological structures and groundwater flow fields. *Environmental Geology* 50: 415-422.
- Hilscherova, K., L. Dusek, V. Kubik, P. Cupr, J. Hofman, J. Klanova, and I. Holoubek. 2007. Redistribution of organic pollutants in river sediments and alluvial soils related to major floods. *Journal of Soils and Sediments* 7(4):67-177.
- Jiang, T., Y.D. Xu, C-Y Chen, X.H. Chen, X. Chen, and V.P. Singh. 2007. Comparison of hydrological impacts of climate change simulated by six hydrological models in the Dongjiang Basin, South China. *Journal of Hydrology* 336: 316-333.
- Jiang, Y. 2006. The impact of land use on soil properties in a karst agricultural region of southwest China: A case study of Xiaojiang watershed, Yunnan. *Journal of Geographical Sciences* 16(1):69-77.
- Lang, Y.C., C.Q. Liu, Z.Q. Zhao, S.L. Li, and G.L. Ha. 2006. Geochemistry of surface and ground water in Guiyang, China: Water/rock interaction and pollution in a karst hydrological system. *Applied Geochemistry* 21:887-903.
- Li, S.L., C.Q. Liu, F.X. Tao, Y.C. Lang, and G.L. Hanet. 2005. Carbon biogeochemistry of ground water, Guiyang, Southwest China. *Ground Water* 43:494-499.
- Li, Y., and J. Zhang. 1999. Agricultural diffuse pollution from fertilizers and pesticides in China. *Water Science and Technology* 39:25-32.
- Li, Y.R., G.H. Huang, Y.F. Li, J. Struger, and J.D. Fischer. 2002. A pesticide runoff model for simulating runoff losses of pesticides from agricultural lands. *Water Science and Technology* 47(1):33-40.
- Liu, Z., C. Groves, D. Yuan, J. Meiman, G. Jiang, S. He, and Q. Li. 2004. Hydrochemical variations during flood pulses in the South-west China peak cluster karst: Impacts of CaCO₃-H₂O-CO₂ interactions. *Hydrological Processes* 18:2,423-2,437.
- Liu, Z., Q. Li, H. Sun, and J. Wang. 2007. Seasonal, diurnal and storm-scale hydrochemical variations of typical epikarst springs in subtropical karst areas of SW China: Soil CO₂ and dilution effects. *Journal of Hydrology* 337:207-223.
- Lu, Y. 2007. Karst water resources and geo-ecology in typical regions of China. *Environmental Geology* 51:695-699.
- Malmon, D., T. Dunne, and S. Reneau. 2002. Predicting the fate of sediment and pollutants in river floodplains. *Environmental Science and Technology* 36:2,026-2,032.
- Ministry of Water Resources. 2007. China to make more efficient use of mine water. 26 Feb 2007. People's Republic of China, Ministry of Water Resources. [online] URL: <http://www.mwr.gov.cn/english1/20070226/82423.asp>. Accessed 20 February 2008.
- Nakanoa, Y., A. Miyazaki, T. Yoshida, K. Ono, and T. Inoue. 2004. A study on pesticide runoff from paddy fields to a river in rural region—1: Field survey of pesticide runoff in the Kozakura River, Japan. *Water Research* 38:3,017-3,022.
- Pesticide Action Network North America. 2008. The Pesticide Action Network Pesticides Database. PANNA. [online] URL: <http://www.pesticideinfo.org/>. Accessed 5 March 2008.
- Quinlan, J., and E. Alexander. 1987. How often should samples be taken at relevant locations for reliable monitoring of pollutants from an agricultural, waste disposal, or spill site in a karst terrane? A first approximation. In B. Beck and W. Wilson, eds., *Proceedings of Multidisciplinary Conference on Sinkholes and Environmental Impacts of Karst*, pp. 277-293. A.A. Balkema, Rotterdam.
- Quinlan, J., and R. Ewers. 1985. Ground water flow in limestone terranes: Strategy rationale and procedure for reliable, efficient monitoring of ground water quality in karst areas. In *Proceedings of Fifth National Symposium and Exposition on Aquifer Restoration and Ground Water Monitoring*, Columbus, OH, 21-24 May 1985, pp. 197-234. National Water Well Association, Worthington, OH.

- Reuters. 2007. China to crack down on banned pesticide use. 7 Aug 2007. Thomson Reuters. [online] URL: <http://www.reuters.com/article/latestCrisis/idUSPEK92660>. Accessed 11 August 2007.
- Shuster, E., and W.B. White. 1971. Seasonal fluctuations in the chemistry of limestone springs: A possible means for characterizing carbonate aquifers. *Journal of Hydrology* 14:93–128.
- Taraba, J.L., J.S. Dinger, L.V.A. Sendlein, and G.K. Felton. 1997. Land use impacts on water quality in small karst agricultural watersheds. In T.M. Younos, ed., *Proceedings: Karst-water Environment Symposium*, Roanoke, VA, 30–31 October 1997, pp. 127–140. Virginia Water Resources Research Center, Blacksburg, VA.
- Turner, J. 2006. New ripples and responses to China's water woes. *The Jamestown Foundation: China Brief* 6(25):8–12. [online] URL: http://www.jamestown.org/images/pdf/cb_006_025.pdf. Accessed 10 May 2007.
- Turner, J., and K. Otsuka. 2006. *Reaching Across the Water: International Cooperation Promoting Sustainable River Governance in China*. Woodrow Wilson International Center for Scholars, China Environment Forum. [online] URL: www.wilsoncenter.org/cef/. Accessed 5 March 2008.
- U.S. Embassy in Beijing, China. 2006. Beijing environment, science, and technology update, January 2006. U.S. Embassy of Beijing, China; Environment, Science, Technology, and Health Section. [online] URL: <http://beijing.usembassy-china.org.cn/esth0106.html>. Accessed 15 June 2009.
- U.S. Environmental Protection Agency. 2003. Drinking water contaminants: Maximum contaminant levels. U.S. Environmental Protection Agency, EPA 816-F-03-016. [online] URL: <http://www.epa.gov/safewater/contaminants/index.html#listmcl>. Accessed 10 August 2008.
- U.S. Geological Survey. 2006. National field manual for the collection of water-quality data: Chapter A4. Collection of water samples. U.S. Geological Survey Techniques of Water-Resources Investigation book 9. [online] URL: http://water.usgs.gov/owq/FieldManual/chapter4/html/C4_contents.html. Accessed 20 April 2007.
- Van Eerd, L.L., R.E. Hoagland, R.M. Zablotowicz, and J.C. Hall. 2003. Pesticide metabolism in plants and microorganisms. *Weed Science* 51(4):472–495.
- Vaute, L., C. Drogue, L. Garrelly, and M. Ghelfenstein. 1997. Relations between the structure of storage and the transport of chemical compounds in karstic aquifers. *Journal of Hydrology* 199(3):221–238.
- Vesper, D.J., C.M. Loop, and W.B. White. 2001. Contaminant transports in karst aquifers. *Theoretical and Applied Karstology* 13–14:101–111.
- Wang, T.Y., Y.L. Lu, R.W. Dawson, Y.J. Shi, H. Zhang, and Y. Xing. 2006. Effects of environmental factors on organochlorine pesticide residues in soils of the Guanting Reservoir area, China. *Journal of Environmental Science and Health, Part B* 41:309–321.
- White, W.B. 1988. *Geomorphology and Hydrology of Karst Terrains*. Oxford University Press.
- White, W.B. 2002. Karst hydrology: Recent developments and open questions. *Engineering Geology* 65:85–106.
- World Bank. 2003. China: Southwest poverty reduction program project. The World Bank, Implementation Completion and Results Report no. 2613230. [online] URL: <http://go.worldbank.org/H6YV3XZ960>. Accessed 20 May 2008.
- World Resources Institute. 1998. Regional profile: China's Health and Environment. In *World Resources 1998–99: Environmental Change and Human Health*, pp. 115–126. World Resources Institute, United Nations Environment Programme, United Nations Development Programme, and The World Bank. [online] URL: http://www.wri.org/pubs/pubs_description.cfm?pid=2889. Accessed 10 September 2007.
- Xinhua News Agency. 2007. 'Officials should be held responsible for pollution.' *China Daily* 27 Feb 2007. [online] URL: http://www.chinadaily.com.cn/china/2007-02/27/content_814500.htm. Accessed 2 March 2008.

Xu, H., Y. Qian, B.Z. Peng, X. Jiang, and X.M. Hua. 2003. Environmental pesticide pollution and its countermeasures in China. *AMBIO* 32(1):78–80.

Yang, P. In press. Study on characteristics of aquifer media of Qingmuguan karst subterranean river system, Southwestern China. In *Proceedings of the 33rd International Geological Congress: International Perspectives on Karst Aquifers and Water Resources (Symposium HYH-09)*, Oslo, Norway, 6–14 August 2008. IGC, International Union of Geological Sciences.

Yang, Y. 2007. Pesticides and Environmental Health Trends in China: A China Environmental Health Project Factsheet. Woodrow Wilson International Center for Scholars, China Environment Forum. [online] URL: www.wilsoncenter.org/cef. Accessed 5 May 2008.

Yuan, D.X., C. Drogue, A. Dai, W.K. Lao, W.T. Cai, P. Bidaux, and M. Razack. 1990. Hydrology of the karst aquifer at the experimental site of Guilin in Southern China. *Journal of Hydrology* 115:285–296.

Zhang, P., L. Li, G. Pan, and J. Ren. 2006. Soil quality changes in land degradation as indicated by soil chemical, biochemical and microbiological properties in a karst area of Southwest Guizhou, China. *Environmental Geology* 51:609–619.

Zheng, F., X. He, X. Gao, C. Zhang, and K. Tanget. 2005. Effects of erosion patterns on nutrient loss following deforestation on the loess plateau of China. *Agriculture, Ecosystems and Environment* 108:85–97.

Impacts of Forest Management on Runoff and Erosion

William J. Elliot, Brandon D. Glaza

Abstract

In a parallel study, ten small watersheds (about 5 ha) were installed in the Priest River Experimental Forest (PREF) in northern Idaho, and another ten were installed in the Boise Basin Experimental Forest (BBEF) in central Idaho. The long-term objective of the study is to compare the effects of different forest management activities on runoff and sediment delivery. This paper reports the observed runoff hydrographs and amounts and the sediment yields during the first 3 to 4 years of the study. During the first 3 years, none of the watersheds received any management treatments or natural disturbances. In the autumn of year 3, a simulated wildfire was carried out at four watersheds in PREF. There was still no runoff from these four watersheds the spring following the fire. These observations will be useful for evaluating the natural variability in hydrologic responses on forest landscapes.

Of the ten sites in PREF, one generated perennial runoff (averaging 231 mm of runoff from 783 mm of precipitation), and one generated only spring runoff averaging 13 mm from 732 mm of precipitation. The other 8 plots generated no runoff. Only the watershed with continuous flow generated any sediment. It averaged 6 kg/ha. In the BBEF study, four to six of the ten watersheds generated seasonal runoff, depending on the year's weather. Of the plots that generated runoff, the average runoff was 34 mm from 555 mm of precipitation. The average sediment yield was less than 1 kg/ha.

Keywords: forest, watershed, hydrology, research

Elliot is a research engineer and Glaza is a civil engineer, U.S. Department of Agriculture Forest Service, Rocky Mountain Research Station, 1221 South Main, Moscow, ID 83843 Email: welliot@fs.fed.us.

Introduction

Our forests are sources of numerous ecosystem services, one of which is clean water. The greatest pollutant of forest streams is sediment. Undisturbed forests generally do not generate sediment, but natural disturbances, such as wildfire or extreme weather events, or human disturbances, such as logging, thinning, prescribed fire, or roads, generally result in an increase in sedimentation from forest watersheds.

In order to estimate the sediment generated from natural or human disturbances, research studies are carried out at plot and watershed scales. Gaged watersheds can vary in size from one or two hectares to thousands of square kilometers. Generally, research watersheds are restricted to less than several hundred hectares to allow researchers to more carefully evaluate effects of specific management activities on watershed response.

One of the properties of forested watersheds is the high level of spatial variability within the watershed. Variability is due to differences in geology, soils, aspect, slope, and vegetation. Prescribed burns and wildfire lead to high variability in the groundcover remaining to protect the mineral soil from raindrop splash and runoff. The amount of cover remaining depends on the amount present before the fire, the water content of the litter, and the severity of the fire (Robichaud 1996).

Forest management has changed in recent years. Effects of logging are much less severe on watersheds due to current logging practices, e.g., leaving buffers around stream channels, locating roads away from streams, limiting the number of skid trails, using low ground pressure skidders, or using forwarders to transport logs (Karwan et al. 2007). Prescribed fire and thinning are becoming more common, particularly in the wildland urban interface (WUI), to remove excess fuels, reduce the risk of wildfire spread, and increase the effectiveness of fire suppression. Managers need to

evaluate the watershed effects from these low-impact activities.

There are two main approaches to forest watershed research. One approach is to use paired watershed studies. With paired studies, “similar” watersheds are identified and monitored for 5 to 10 yrs with no treatment. The runoff amounts and sediment yields are collected from the two watersheds and the differences are noted. One of the pair is then treated and the other is left untreated. In the years following the treatment, the differences between the two watersheds are once again measured, and the researcher evaluates any change in differences between the pair and assumes that the change reflects the treatment effects.

The second approach for many watershed studies is to install “nested” watersheds, a smaller watershed monitored within a larger watershed. Sometimes a paired watershed study may be nested within a large watershed (Hubbart et al. 2007). The purpose of the nested approach is to evaluate the effect of a treatment in the smaller watershed at ever increasing scales.

Both of these study designs are dependent on watersheds with similar properties. The degree of similarity, however, may be difficult to predict. If sites are identified during dry seasons, or during wet seasons, there may be no apparent differences, but during critical times mid-season, one watershed may continue to generate runoff and sediment for several weeks after an adjacent one has ceased to flow.

A common practice following wildfire is to carry out a “salvage logging” operation, where fire-killed trees are harvested to obtain at least some economic return from the burned forest and reduce fuel loading and future fire risk. The watershed impacts of salvage logging are not known (Beschta et al. 1995), and there is a need to carry out a number of studies of salvage logging impacts under different conditions.

In order to reduce the risk of wildfire, a common forest practice is to carry out thinning with or without prescribed fire (Graham and Jain 2005). These activities tend to be low impact, but little information is available of the impact of such operations.

There is a need to understand variability between watersheds, to better evaluate observations from paired and nested watershed studies. There is also a need to

evaluate the impacts of current forest management practices on runoff and sediment delivery from forest watersheds.

The specific objectives of this paper are:

1. To describe a study that measures the watershed impacts of current forest fuel management practices including wildfire and salvage logging, and
2. To present the runoff and erosion rates from these watersheds observed during the first 3 to 4 yrs in order to evaluate natural variability and fire effects in small watershed studies.

Methods

Research sites

In order to evaluate the variability in small forest watershed studies, ten small watersheds were installed in each of two experimental forests managed by the U.S. Forest Service Rocky Mountain Research Station. One location was in the Priest River Experimental Forest (PREF) located in the Idaho Panhandle National Forest about 20 km north of the Priest River, ID. The other location was in the Boise Basin Experimental Forest (BBEF) located about 80 km northeast of Boise, ID, in the Boise National Forest (Figure 1).

The soils on the PREF “are categorized within the Typic Vitrandepts soil complex. These soils have a thick mantle of volcanic ash-influenced loess from Cascade volcanoes overlaying belt series parent material. Variations within the major soil complex are dependent on elevation, slope, aspect, and topographic position” (Schmidt and Friede 1996, p. 53). In the BBEF, “soils are derived from granitic rocks of the Idaho Batholith. The rocks are mostly quartz monzonite with some porphyritic and aplitic dikes. The soils are generally deep except on extremely steep slopes and ridges and are mostly coarse to moderately coarse in texture. Representative soils are mostly Typic or Lithic Xeropsamments, Cryumbrets, Cryoboralls, Cryorthents and Cryochrepts” (Schmidt and Friede 1996, p. 42).

At PREF, four of the watersheds were in western red cedar (*Thuja plicata*) and six were in grand fir (*Abies grandis*) habitat types. Time since last harvesting or thinning operations varied from 10 to 100 years. The watersheds experiencing the more recent (about 10 years) thinnings were selected for control treatments.

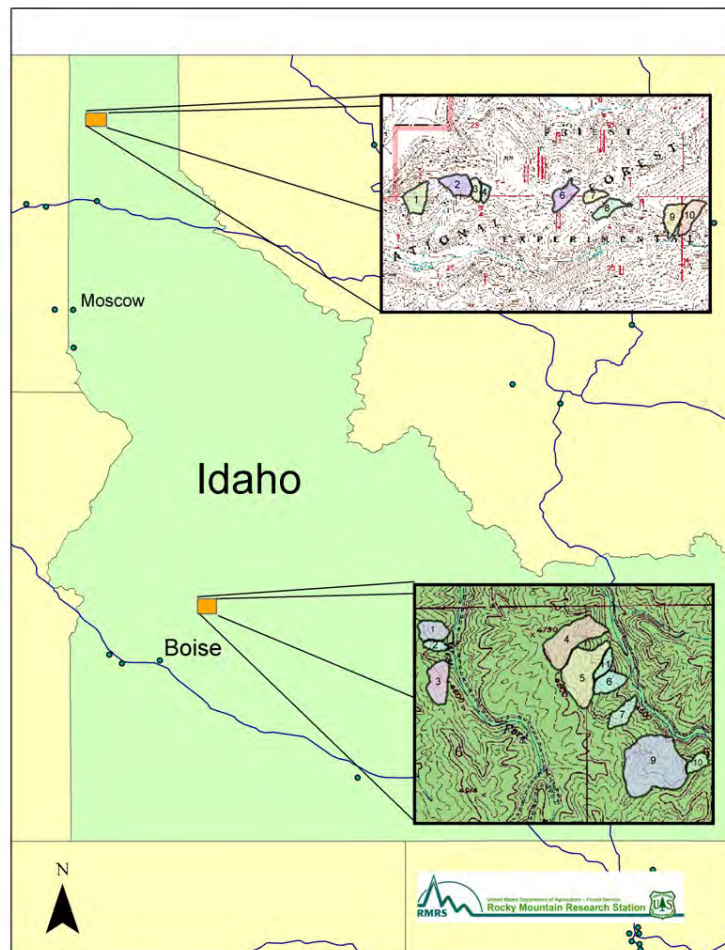

Figure 1. Location of Priest River (top/north) and Boise Basin (bottom/south) Experimental Forests.

These watersheds would not easily carry wildfire, nor did they have vegetation in need of thinning. None of the watersheds had experienced harvesting in the past 50 years. Interior ponderosa pine (*Pinus ponderosa*) is the predominant forest cover type on the BBEF experimental forest (Schmidt and Friede 1996). In the BBEF, none of the watersheds have been disturbed by fire, thinning, or harvesting in the past 50 years. Prior to that, the watersheds appeared to have been clear cut harvested as the stands were uniform in age.

Treatments

The same study plan was used by installing ten small watersheds at both PREF and BBEF to facilitate statistical analysis (Tables 1, 2). Each site had two main treatments, simulated wildfire (four watersheds) and thinning (four watersheds), as well as an

undisturbed control (two watersheds) for a total of ten. Following the wildfire treatment, two of the wildfire plots are treated with a salvage logging operation to remove large trees with economic value. Following the thinning, two of the thinned plots are treated with a mastication operation, shredding the slash, young trees, and other short growing vegetation. The other two thinned plots will be treated with a prescribed fire to remove slash and reduce short vegetation. Treatments were selected to suit the vegetation condition of each watershed. For example, watersheds in least need of treatment to minimize wildfire risk were chosen as controls. Adjacent watersheds were selected for the wildfire treatments to minimize the amount of fire line that would have to be dug prior to the wildfire treatment. Watersheds with merchantable timber were selected for thinning to increase the chance of completing a timber sale (Graham and Jain 2005).

Watersheds

The watersheds to be treated with simulated wildfire were all under 5 ha. A number of wildfire and fuel management treatments have been completed on watersheds of this size (e.g., Covert et al. 2005, Robichaud 2005), so keeping a similar size makes observations from our studies easy to compare to a number of studies of similar scale with similar erosion and sedimentation processes.

At Priest River, the watersheds were all south or southwest facing (Figure 2). Outlet elevations ranged from 841 m on the west to 1,040 m on the easternmost watershed (Table 1). Areas ranged from 1.7 ha to 6.5 ha, with the smaller watersheds used for the wildfire treatments. Average slopes ranged from 21 to 43 percent. One weather station was installed near watershed 2 to provide lower elevation weather data, and a second weather station was installed near watershed 7. All of these watersheds drain into Benton Creek. Watersheds 9 and 10 are upstream from a weir that has been monitoring flow for 70 years.

The Boise Basin watersheds have an east-northeast aspect and are located on two adjacent ridges (Figure 3), so there is a smaller range of elevations (Table 2). Outlet elevations ranged from 1,338 m to 1,424 m. The watershed areas ranged from 0.9 ha to 12.2 ha. The largest watershed (9) was used as a control to minimize the risk of overwhelming the outlet flume. The wildfire watersheds were smaller. Average slopes ranged from 24 to 46 percent. Watershed 8 was originally intended to be one of the wildfire treatment watersheds. Following installation, however, the Forest Service fire management specialist determined that it would be difficult to contain a “simulated wildfire” on this small watershed, and there was a risk that the fire could spread to the large control watershed 9. The following year, an additional watershed, number 11, was installed

to use instead of watershed 8 for the wildfire treatment. Hence, watershed 8 is not listed in Table 2, but the outlet structure is still in place. A single weather station was considered to be sufficient for this site because there was not a large variation in elevation among the watersheds.

Groundcover was measured on all the watersheds following methods developed for measuring fire severity to support ground truthing for satellite imagery (Hudak et al. 2007). A 60-m grid was established to reference groundcover and vegetation response to treatments. At each grid point, a tape was extended in a random direction, and four measurement points at a 10-m spacing along a linear transect were defined. At each measurement location, a 1-m² frame with 100 points was placed on the ground and the material beneath the grid recorded. Material classes were mineral soil, ash, rock, woody material, organic material, and charcoal. The number of points in each class was converted to a percent and averaged for each watershed.

Outlet structures

For the control, thinning, and thinning plus prescribed fire plots, metal borders were installed at the bottom of each plot to divert the runoff water to a 300-mm pipe. The pipe conveys the water to a large covered 1-m³ plastic box that serves as a sediment trap (Figure 4). The outflow from the trap is diverted to a 2-m long fiberglass trough leading to a 1-ft nominal fiberglass H-flume with a stilling basin. Flow depth in the H-flume is measured with a MagneruleTM and recorded at 30-min intervals on a nearby data logger (Figure 4).

The wildfire sites are designed similarly to those used in other wildfire erosion studies (Robichaud 2005). A 2-m-high sheet metal and wood post barrier was installed on one of the watersheds destined for a wildfire treatment in the Boise Basin Experimental

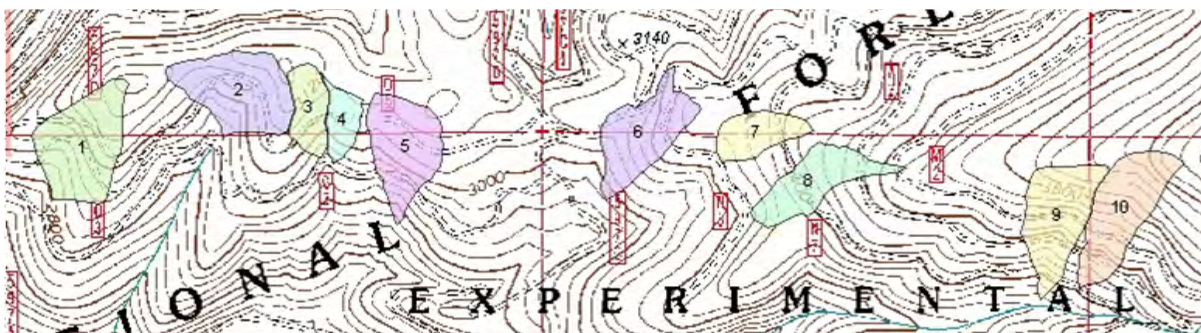

Figure 2. Locations of the watersheds in the Priest River Experimental Forest.

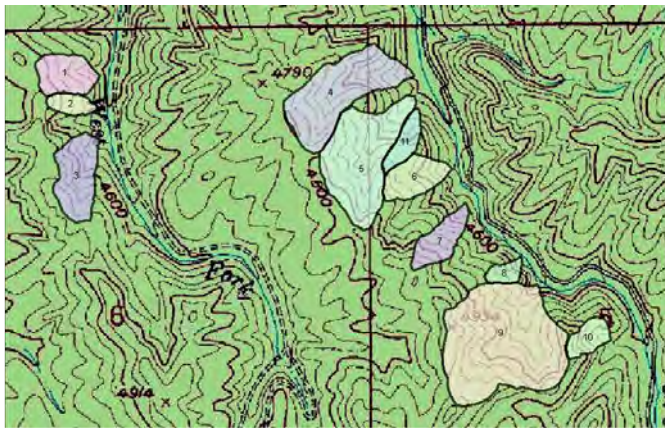

Figure 3. Location of watersheds in the Boise Basin Experimental Forest.



Figure 4. Sediment box and flume for control and thinned plots at the Boise Basin Experimental Forest.



Figure 5. V-notch weir and headwall on one of the watersheds destined for a wildfire treatment in the Boise Basin Experimental Forest.

Forest across the watershed outlet. A 300-mm 90° V notch was cut in the sheeting to serve as a V-notch weir, approximately 1.5 m above the elevation of the existing waterway (Figure 5). Following a major erosion event, the erosion can be estimated by measuring the accumulated volume of sediment, if it is large, or by excavating all of the deposited sediment and weighing it by the bucket until the collection basin is empty (Robichaud 2005).

Simulated wildfire, salvage logging, and thinning

To simulate the effects of a wildfire, trees that were likely to be killed by a wildfire were selected in each plot (Graham and Jain 2005). The selected trees were girdled in the summer before the fire. Local Forest Service fire crews burned PREF watersheds 3, 4, 7, and 8 in October 2006, and BBEF watersheds 6, 7, 10, and 11 in June 2008. A fire break was manually dug around each watershed and a fire hose laid around the perimeter prior to burning. Each watershed was then ignited with propane torches around the perimeter, from the top to the bottom. Instrumentation was protected with fire blankets and dampened to prevent damage (Figure 6).

Results

The runoff amounts from the watersheds are presented in Tables 1 and 2. During 2004, installation problems and low batteries at both the PREF and BBEF sites resulted in data loss. There was sufficient information, however, to determine which watersheds generated runoff and which did not. The equipment malfunctioned during the main spring runoff events on these watersheds, likely a result of freezing.

At PREF there were only two watersheds that generated any runoff (Table 1). Watershed 6 had runoff during the spring snowmelt season, and watershed 10 had runoff throughout the year, including midwinter when the watershed was covered in snow and late summer when the site had not experienced significant precipitation for several months.

For the BBEF sites (Table 2), there was runoff observed from watershed 9 in 2004, watersheds 1, 2, 5, and 9 in 2005, and watersheds 1–5 and 9 in 2006.

The average precipitation for the PREF sites was 729 mm, and for the BBEF site 513 mm (Table 3). The

BBEF gage did not function from Jan. 1 until April 30 in 2007, so data from the nearby Garden City Ranger District was used as an estimate. At PREF, the lower gage (elevation 883 m) averaged 708 mm, whereas the higher elevation gage (989 m) averaged 751 mm during the 3 yrs of observations.

The average annual temperature was 12.2°C for PREF and 6.8°C for BBEF (Table 4). At the BBEF site, the temperature data sensors malfunctioned between Jan. 1 and May 18, 2005, and between June 1 and Sept. 19, 2006. For these dates, data from the Idaho City weather station (elevation 1,201 m), 5.2 km northwest of the site, were used.

Pre-disturbance groundcover observed at PREF was 98 to 100 percent on all watersheds except watershed 9 that had 96 percent cover (Table 5). At BBEF groundcover was between 90 and 100 percent (Table 6), averaging 96 percent. The groundcover was mainly decomposing organic material (83–95 percent) and woody material (4–17 percent).

The hydrographs from some of the watersheds were drawn to ascertain differences in the timing of the runoff. The hydrographs from the small watersheds were compared to nearby watersheds to see how well the small watershed reflected the response of watersheds at a large scale. In the PREF, two of the watersheds were nested within the Benton Creek drainage, which has been monitored since the 1930s. The Benton Creek Watershed has an area of 385 ha and is entirely forested (Stage 1957). The range of elevations on the research watersheds (841–1,270 m) is similar to the elevation within the Benton Creek watershed (810–1,679 m). The ten research watersheds are located at mid-elevation in this watershed. In the BBEF, a nearby watershed, Mores Creek, has a U.S. Geological Survey (USGS) gauging station (U.S. Geological Survey 2007). The area above the Mores Creek gage is 103,385 ha and is predominantly forested. The BBEF plots are similar in elevation to the midlevel elevation of Mores Creek. Figure 7 shows the hydrographs for two small watersheds at PREF and two at BBEF, as well as the hydrographs from the nearby large watersheds.

Only two watersheds generated any sediment during the 3 yrs of observation (Table 7). The observed sediment yields were very low (under 10 kg ha⁻¹), and appeared to

be coming from the channel. No erosion features were observed on the hillslopes.



Figure 6. Protecting the instrumentation with fire blankets and water during the simulated wildfire at the Priest River Experimental Forest in October 2006.

[Continued on next page]

Table 1. Details of watersheds in the Priest River Experimental Forest.

Watershed	Tmt*	Area (ha)	Avg. slope (%)	Elev. (m)	Observed runoff for year (mm)			
					2004	2005	2006	2007
1	Thin/Mast	6.5	30	857	0.0	0.0	0.0	0.0
2	Thin/Mast	6.2	27	878	0.0	0.0	0.0	0.0
3	Burn	2.4	21	890	0.0	0.0	0.0	0.0
4	Burn/Salv	1.7	21	890	0.0	0.0	0.0	0.0
5	Thin/Burn	5.3	28	841	0.0	0.0	0.0	0.0
6	Control	5.1	21	902	RO**	14.1	11.5	46.3
7	Burn	2.6	27	988	0.0	0.0	0.0	0.0
8	Burn/Salv	4.2	27	988	0.0	0.0	0.0	0.0
9	Thin/Burn	5.5	43	1,012	0.0	0.0	0.0	0.0
10	Control	5.9	41	1,040	RO**	196.5	248.9	248.9
Average		4.5	29	929				

* Watershed treatment.

** On these plots, runoff (RO) was observed in 2004, but the amount was not measured.

Table 2. Details of watersheds in the Boise Basin Experimental Forest.

Watershed	Tmt*	Area (ha)	Avg. slope (%)	Elev. (m)	Observed runoff for year (mm)		
					2004	2005	2006
1	Thin/Mast	2.2	29	1,354	0.0	RO**	15.7
2	Thin/Burn	0.9	35	1,357	0.0	RO**	3.1
3	Control	3.2	30	1,357	0.0	0.0	11.6
4	Thin/Mast	6.4	24	1,338	0.0	0.0	16.2
5	Thin/Burn	7.0	27	1,351	0.0	RO**	123.4
6	Burn/Salv	2.1	40	1,357	0.0	0.0	0.0
7	Burn	1.9	46	1,363	0.0	0.0	0.0
9	Control	12.2	26	1,387	RO**	RO**	34.3
10	Burn/Salv	1.2	37	1,424	0.0	0.0	0.0
11	Burn	1.2	34	1,363	0.0	0.0	0.0
Average		3.8	33	1,365			

* Watershed treatment.

** On these plots, runoff (RO) was observed but the amount was not measured accurately.

Table 3. Observed annual precipitation at the Priest River (PREF) and Boise Basin (BBEF) Experimental Forests.

Station			Year and precipitation (mm)				
PREF	Applies to watersheds	Elevation (m)	2004	2005	2006	2007	Avg
Weather 1	1-5	883	736.6	672.6	786.9	636.5	708.2
Weather 2	6-10	989	795.0	760.7	794.8	651.8	750.6
BBEF							
Weather 1	All	1,363	partial year	595.4	514.4	430.3	513.4

Table 4. Average annual daily temperatures for the Priest River and Boise Basin research sites.

	Elev (m)	Average temperature (°C)			
		2005	2006	2007	Average
PREF					
Weather1	883	14.0	14.8	14.4	14.4
Weather2	989	10.0	10.5	10.7	10.4
BBEF					
Weather1	1,363	6.5	6.7	7.1	6.8

Table 5. Groundcover observations (percentage) prior to any disturbance on the Priest River Experimental Forest watersheds.

	WS1	WS2	WS3	WS4	WS5	WS6	WS7	WS8	WS9	WS10
Mineral Soil	2	1	0	0	0	1	0	0	4	0
Ash	0	0	0	0	0	0	0	0	0	0
Rock	0	0	0	0	0	0	0	0	1	0
Woody matl.	4	4	17	10	15	13	15	12	10	5
Organic matl.	94	95	83	90	85	86	85	88	85	95
Charcoal	0	0	0	0	0	0	0	0	0	0

Table 6. Groundcover observations (percentage) prior to any disturbance on the Boise Basin Experimental Forest watersheds.

	WS1	WS2	WS3	WS4	WS5	WS6	WS7	WS9	WS10	WS11
Mineral soil	0	1	3	7	4	2	0	2	10	1
Ash	0	0	0	0	0	0	0	0	0	0
Rock	0	0	0	0	0	0	0	0	0	0
Woody matl.	15	5	8	4	9	12	16	10	2	9
Organic matl.	85	94	89	89	87	86	84	88	88	90
Charcoal	0	0	0	0	0	0	0	0	0	0

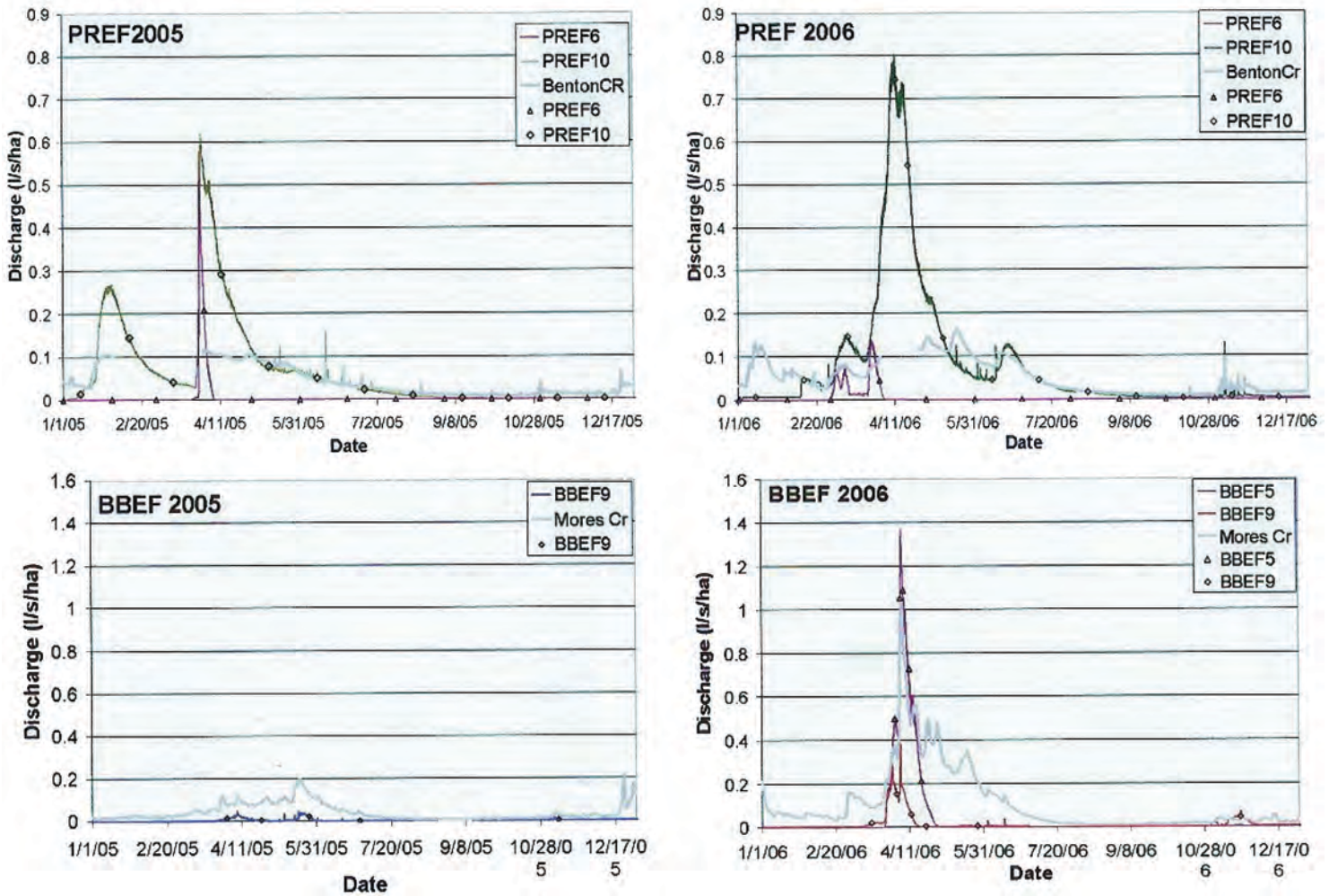

Figure 7. Hydrographs for 2005 and 2006 for selected small watersheds at Priest River and Boise Basin Experimental Forests compared to nearby larger watersheds of Benton Creek and Mores Creek, respectively.

Discussion

In the current condition, the watersheds are exhibiting a wide range of variability. Only two of the ten watersheds at PREF had any observed runoff, whereas six of the watersheds at BBEF had runoff. Even though the climate at BBEF is drier than at PREF (Table 3), there were more watersheds with runoff, likely due to the lower water holding capacity of the coarse textured soils at BBEF (Schmidt and Fried 1996). It is hypothesized that the one watershed at PREF that was generating significant runoff year round likely had a more shallow soil or less permeable bedrock. The geologic map of the area shows that the bottom quarter of watershed 10 was underlain by metamorphic rock

that was not present in any of the other watersheds except the last few meters of watershed 9 (Miller et al. 1999). The soils at PREF are more variable than at BBEF (Schmidt and Friede 1996, Miller et al. 1999). Generally, the larger the watershed at BBEF, the more likely it is to generate runoff ($r^2 = 0.3$). This scaling effect on runoff was noted at a larger scale in a comparison of a 106-ha watershed to a 177-ha watershed by Zhang et al. (2009).

The BBEF site is 500 km south of the PREF site, but because of the higher elevation, is cooler (Table 4). As snowmelt dominates the hydrology on both of these sites (Figure 7), the importance of these temperature differences is an area requiring further investigation.

Table 1 shows that the ephemeral watershed at PREF (watershed 6) generated more runoff in 2005, even though there was less precipitation than in 2006. This is likely a reflection of high snowmelt rates that dominated runoff of this watershed because the majority of the runoff from this watershed occurred between March 23 and April 7, a duration of 15 days in 2005, compared to a melt period from February 28 until April 17 in 2006, a duration of 48 days. The perennial-flow watershed at PREF (watershed 10) generated 52 mm more runoff in 2006 than 2005, likely due to the 70-mm difference in precipitation. Also, watershed 10 has a higher elevation, which resulted in a greater depth of snow (Elliot 2007) and a prolonged snowmelt period (Figure 7). Although 2006 was wetter than 2005 at the PREF watersheds, at BBEF there was 81 mm less precipitation in 2006 than in 2005. This reduced precipitation in 2006 at BBEF is not reflected in the observed runoff values, which were greater in 2006 on four watersheds and less on only two. The reason for this unexpected response may be linked to the timing and rate of snowmelt.

The groundcover was greater at Priest River than at Boise Basin (Tables 5 and 6). This difference in cover is likely due to the higher precipitation amounts at PREF (Table 3). The cooler temperatures (Table 4) at BBEF may have resulted in reduced vegetation growth, which would also result in less accumulation of groundcover. The reduced groundcover at Boise Basin may have contributed to the higher observed runoff rates (Pannkuk and Robichaud 2003, Fangmeier et al. 2006, p 81). There may also be differences between the two vegetation types (Pannkuk and Robichaud 2003).

The hydrographs in Figure 7 show that the small watersheds in this study generate normalized runoff with higher peak flows during the spring snowmelt season than do the nearby larger watersheds, but they experience a much faster decline in the falling limb of the hydrograph. The peak flow rates occur in early April at both PREF and BBEF, so apparently the differences in elevation of the two forests are offset by the differences in latitude (48.3 vs. 43.7°N). At both sites, the nearby larger watersheds continue to discharge water from snowmelt at higher elevations and likely from groundwater seepage after the snowmelt season as well.

At PREF, the watershed with the perennial flow was the only watershed that generated any sediment. At BBEF, sediment was generated by only one of the watersheds

(watershed 9), which also runs most of the year. BBEF watershed 9, however, was not the watershed generating the greatest depth of runoff. It was the largest watershed in the study (12.2 ha), and its channel is more likely to generate sediment than channels on the smaller watersheds. Zhang et al. (2009) made a similar observation on the effect of forest watershed size on sediment delivery with the channel from a 106-ha watershed generating 13 kg/ha/y compared to the channel from a larger 177-ha watershed, in which the smaller one was nested, generating 26 kg/ha/y. Onsite observations indicated that the sediment source was the channel and not the forested hillslopes.

The absence of runoff and erosion following the simulated wildfires at PREF was not expected. Some localized soil displacement was observed on watersheds 7 and 8, but no sediment was collected at any of the outlet weirs. Earlier observations at PREF had suggested that these soils resisted erosion, and this study confirms those observations.

Conclusions

Ten small watersheds (under 10 ha) have been installed in the Priest River Experimental Forest in northern Idaho, and another ten in the Boise Basin Experimental Forest in central Idaho. Differences in geology and climate between these two locations resulted in only two watersheds generating runoff at Priest River, compared to six at Boise Basin. Both total precipitation amount and the timing and rate of snowmelt runoff, affect the total runoff as well as the peak runoff rate and duration of runoff. The role of snowmelt processes on runoff characteristics warrants further investigation.

Acknowledgments

The authors wish to acknowledge the assistance of Jill Cobb and other specialists from the Idaho Panhandle National Forest, and Hana West and other specialists from the Boise National Forest, for support in completing the environmental analyses necessary to carry out the larger study and for hosting the research plots in their respective National Forests. We also wish to acknowledge Bob Denner and scientists within the Rocky Mountain Research Station for assistance in planning and in providing collaborative research related to vegetation and soil properties.

References

- Beschta, R.L., C.A. Frissell, R. Gresswell, R. Hauer, J.R. Karr, G.W. Minshall, D.A. Perry, and J.J. Rhodes. 1995. Wildfire and Salvage Logging: Recommendations for Ecologically Sound Post-Fire Salvage Logging and Other Post-Fire Treatments on Federal Lands in the West. Save America's Forests. [online] URL: <http://www.saveamericasforests.org/congress/Fire/Beschta-report.htm>. Accessed 15 August 2008.
- Covert, S.A., P.R. Robichaud, W.J. Elliot, and T.E. Link. 2005. Evaluation of runoff prediction from WEPP-based erosion models for harvested and burned forest watersheds. *Trans. of the ASAE (American Society of Agricultural Engineers)* 48(3):1,091–1,100.
- Elliot, B. 2007. Notions on modeling snowmelt process in forested watersheds. Presented at the USDA-ARS Winter Erosion Processes and Modeling Meeting, W. Lafayette, IN, 1-3 May 2007. U.S. Department of Agriculture–Agricultural Research Service.
- Fangmeier, D.D., W.J. Elliot, S.R. Workman, R.L. Huffman, and G.O. Schwab. 2006. *Soil and Water Conservation Engineering* (5th ed.). Thomson Delmar Learning, Clifton Park, NY.
- Graham, R.T., and T.B. Jain. 2005. Application of free selection in mixed forests of the inland northwestern United States. *Forest Ecology and Management* 209:131–145.
- Hubbart, J.A., T.E. Link, J.A. Gravelle, and W.J. Elliot. 2007. Timber harvest impacts on water yield in the continental/maritime hydroclimate region of the U.S. *Journal of Forestry* 53(2):169–180.
- Hudak, A.T., P. Morgan, M.J. Bobbit, A.M.S. Smith, S.A. Lewis, L.B. Lentile, P.R. Robichaud, J.T. Clark, and R.A. McKinley. 2007. The relationship of multispectral satellite imagery to immediate fire effects. *Fire Ecology* 3(1): 64–90.
- Karwan, D.L., J.A. Gravelle, and J.A. Hubbart. 2007. Effects of timber harvest on suspended sediment loads in Mica Creek, Idaho. *Forest Science* 53(2):181–188.
- Miller, F.K., R.F. Burmester, D.M. Miller, R.E. Powell, and P.D. Derkey. 1999. Digital geologic map of the Sandpoint 1- by 2-degree quadrangle, Washington, Idaho and Montana. U.S. Geological Survey Open-File Report 99-144. [online] URL: <http://wrgis.wr.usgs.gov/open-file/of99-144/>. Accessed October 2008.
- Pannkuk, C.D., and P.R. Robichaud. 2003. Effectiveness of needle cast at reducing erosion after forest fires. *Water Resources Research* 39(12): 1,333–1,345.
- Robichaud, P.R. 1996. Spatially-varied erosion potential from harvested hillslopes after prescribed fire in the interior northwest. University of Idaho. Ph. D. dissertation. Moscow, ID.
- Robichaud, P.R. 2005. Measurement of post-fire hillslope erosion to evaluate and model rehabilitation treatment effectiveness and recovery. *International Journal of Wildland Fire* 14:475–485.
- Schmidt, W.C., and J.L. Friede. 1996. *Experimental forests, ranges, and watersheds in the Northern Rocky Mountains: A compendium of outdoor laboratories in Utah, Idaho, and Montana*. U.S. Forest Service Intermountain Research Station (Ogden, UT), General Technical Report INT-GTR-334.
- Stage, A.R. 1957. Some runoff characteristics of a small forested watershed in northern Idaho. *Northwest Science* 31:14–27.
- U.S. Geological Survey. 2007. USGS 13200000 Mores Creek AB Robie Creek NR Arrowrock Dam ID. U.S. Geological Survey National Water Information System. [online] URL: http://waterdata.usgs.gov/nwis/dv?referred_module=sw&site_no=13200000. Accessed April 2007.
- Zhang, J.X, J.Q. Wu, K. Chang, W.J. Elliot, and S. Dun. 2009. Effects of DEM source and resolution on WEPP hydrologic and erosion simulation: A case study of two forest watersheds in Northern Idaho. *Transactions of the ASABE American Society of Agricultural and Biological Engineers*. 52(2): 447-457.

Modeled Watershed Runoff Associated with Variations in Precipitation Data, with Implications for Contaminant Fluxes: Initial Results

Heather E. Golden, Christopher D. Knightes, Ellen J. Cooter, Robin L. Dennis

Abstract

Precipitation is one of the primary forcing functions of hydrologic and watershed fate and transport models; however, in light of advances in precipitation estimates across watersheds, data remain highly uncertain. A wide variety of simulated and observed precipitation data are available for use in regional air quality models and watershed fate and transport models. Although these single media models can potentially link together to estimate contaminant loadings issuing from watersheds, questions remain concerning how precipitation data from diverse sources used within each model affect water and contaminant mass balances. We assess how two sets of spatially distributed precipitation data, simulated at 12-km grid and 36-km grid resolutions, affect runoff simulated from a spatially distributed grid-based mercury watershed model that has been calibrated using observed precipitation data. We focus on two headwater catchments in the Cape Fear River Basin, NC. Our initial results suggest that precipitation data

simulated at a coarse resolution (e.g., 36-km grid) decreases the efficiency and goodness-of-fit of modeled runoff, but this is watershed specific. Variations in the response to coarse resolution precipitation potentially results from differences in the size and within stream structural modifications of each watershed. These initial results are assessed within the context of a broader project that will also evaluate the effects of radar and empirically-estimated precipitation data sets on modeled runoff and variations in watershed contaminant loading resulting from these diverse precipitation inputs.

Keywords: precipitation, rainfall-runoff modeling, fate and transport modeling, runoff efficiency

Introduction

Watershed-scale fate and transport models are important tools for estimating the sources, transformation, and transport of contaminants to surface water systems. Precipitation is one of the primary inputs to watershed biogeochemical models, influencing changes in the water budget of the surface, shallow subsurface, and deep groundwater zones, and as a result, the transport of contaminants to surface water systems. Estimates of precipitation across watersheds are notably imperfect, partially stemming from the sparse coverage of monitoring networks, the coarse resolution of simulated data, and the dynamic temporal and spatial nature of precipitation events. Further, most watershed fate and transport modeling studies are limited by precipitation data representing only a few sites within or near the watersheds. Although improvements to rainfall estimates across watersheds have been made in recent years (e.g., NEXRAD, satellite imagery, modification in rainfall

Golden is a physical scientist, Ecosystems Research Division, U.S. Environmental Protection Agency/ Office of Research and Development/ National Exposure Research Laboratory (USEPA/ORD/NERL), Athens, GA 30605. Knightes is an environmental engineer, Ecosystems Research Division, USEPA/ORD/NERL, Athens, GA 30605. Cooter is a meteorologist, Atmospheric Modeling Division, USEPA/ORD/NERL, Research Triangle Park, NC 27711. Dennis is a senior scientist, Atmospheric Modeling Division, USEPA/ORD/NERL, Research Triangle Park, NC 27711. Email: Golden.Heather@epa.gov.

gage density), few advancements to these precipitation estimates are made within the context of rainfall-runoff and watershed contaminant flux modeling (see Andréassian et al. 2001). Questions remain concerning the response of modeled runoff generation and consequent contaminant fluxes in watersheds to these new sources of precipitation data.

Atmospheric deposition (of nutrients and metals) is also an important input to watershed models estimating non-point source loads from the landscape, particularly in portions of watersheds where atmospheric sources are a significant component of mass balance calculations (e.g., deposition of reactive nitrogen in forested areas; Boyer et al. 2002). Although estimates of atmospheric deposition for watershed fate and transport modeling are typically derived from individual point monitoring locations, these data are sparse and require multiple interpolation techniques for broad spatial coverage. Acquiring atmospheric deposition estimates from spatially-resolved (i.e., grid-cell) process-based regional air quality models (e.g., Community Multiscale Air Quality (CMAQ) for wet deposition) potentially resolves these issues, particularly for mesoscale and large watershed modeling efforts. However, precipitation rates used in these models to estimate deposition from atmospheric concentrations often derive from different sources and estimation techniques than those applied in watershed fate and transport modeling. For example, CMAQ uses regionally-simulated rainfall data while watershed fate and transport models often use observed data from monitoring stations. This leads to a potential decoupling between the rainfall component estimating atmospheric deposition from concentrations in air quality models, for example, and precipitation data (e.g. observed, radar, or other simulations) applied to estimate runoff and contaminant loads to surface waters. As a result, estimates of nutrient and metal loadings are over or underestimated because of the potential differences in the simulated water and chemical mass balance budget.

Several studies have assessed the effect of using multiple precipitation data sets on modeled runoff; however, the approach is either focused on broad, global data sets of precipitation (e.g., Fekete et al. 2004), variations in the density of observed rainfall stations (Andréassian et al. 2001), or comprehensive uncertainty analyses of radar rainfall estimation and modeled runoff (Carpenter and Georgakakos 2004, Hossain et al. 2004). Few studies have focused on the

effects of using several different types of precipitation data sets, which vary both spatially and in how estimates are derived (i.e., observed vs. simulated, radar, and empirically-estimated), on watershed loading estimates.

The goal of this paper is to present results from our study assessing how precipitation data derived from multiple sources (currently, observed and regionally-simulated) and at different spatial scales affect the rainfall-runoff component of a watershed fate and transport model. This paper is the initial phase of a larger project investigating how decoupled precipitation data used within regional atmospheric and watershed fate and transport models affect both water flux and contaminant loading from watersheds to surface waters. We pose the questions:

1. How does the spatial resolution of simulated precipitation affect modeled runoff generated from a semi-distributed watershed fate and transport model that is calibrated using observed precipitation data?
2. As data sets of precipitation at multiple spatial scales become increasingly available for use in mesoscale to large scale water quality modeling, what precipitation data generates runoff most accurately?

The findings presented here are initial assessments and begin to advance current understanding of the relationships between the spatial variability and sources of precipitation estimates and accuracy of simulated runoff, particularly related to linking air quality and watershed fate and transport models. The next phase of our project will analyze the effects of additional precipitation data sets (including the National Multi-sensor Precipitation Analysis (NPA)) on watershed runoff and contaminant loading estimates.

Study Area

The study was conducted in two watersheds located within the headwaters of the Cape Fear River Basin, NC (Figure 1). The two watersheds include the Deep River Watershed (area above stream gage = 906 km²) and Haw River Watershed (area above stream gage = 3,296 km²) located in the Piedmont region of North Carolina and draining to the Coastal Plain system. Both watersheds have similar landcover characteristics (41–45 percent forested, 25–28 percent pasture, 18–27 percent developed) and topographic variations. Our goal was to assess watersheds within the same climatic

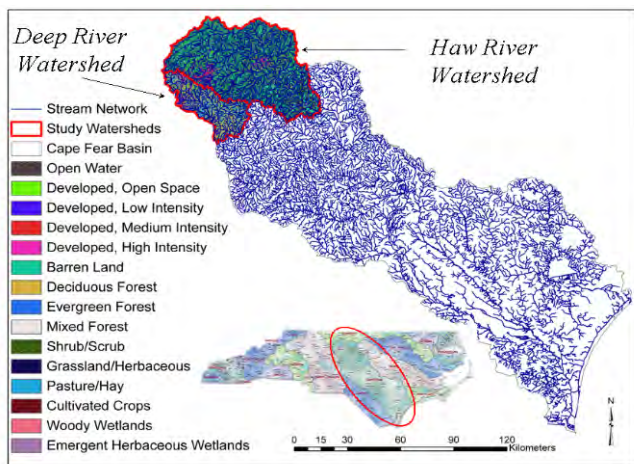

Figure 1. The Deep and Haw River Watersheds within the Cape Fear River Basin, including landcover (MRLC 2001).

regime and with relatively similar landcover and elevation characteristics, though some physical variations (e.g., size and flow alterations such as lock and dam systems and channelization in developed areas) do exist.

Methods

Precipitation data

As part of the initial phase of the project, we utilized three precipitation data sets with varying spatial resolutions for comparison: (1) observed monitoring data from National Oceanic and Atmospheric Administration National Climatic Data Center (NCDC) COOP stations (National Climatic Data Center 2008) at two sites within or bordering the Deep River Watershed and five sites within or bordering the Haw River Watershed; (2) 36-km grid cell simulated data from the Pennsylvania State University/National Center for Atmospheric Research mesoscale model (MM5); and (3) 12-km grid cell simulated MM5 data (Figure 2). We used data from 2001–2003, which are representative of wet, dry, and normal years across the southeastern United States (National Oceanic and Atmospheric Administration 2008). The MM5 model is a regional (mesoscale) modeling system that simulates and predicts regional atmospheric circulation (Grell et al. 1995). Both 12-km and 36-km MM5 precipitation data sets are used in computations of depositional fluxes of nitrogen, sulfur, and mercury species within the CMAQ regional air quality model (Bullock and Brehme 2002, Byun and Schere 2006), which will be implemented in subsequent phases of the project.

Daily precipitation data from each source were applied to a grid-based mercury model (GBMM; see below) to assess how variations in precipitation affect modeled runoff in the Deep River and Haw River subwatersheds of the Cape Fear River Basin, NC.

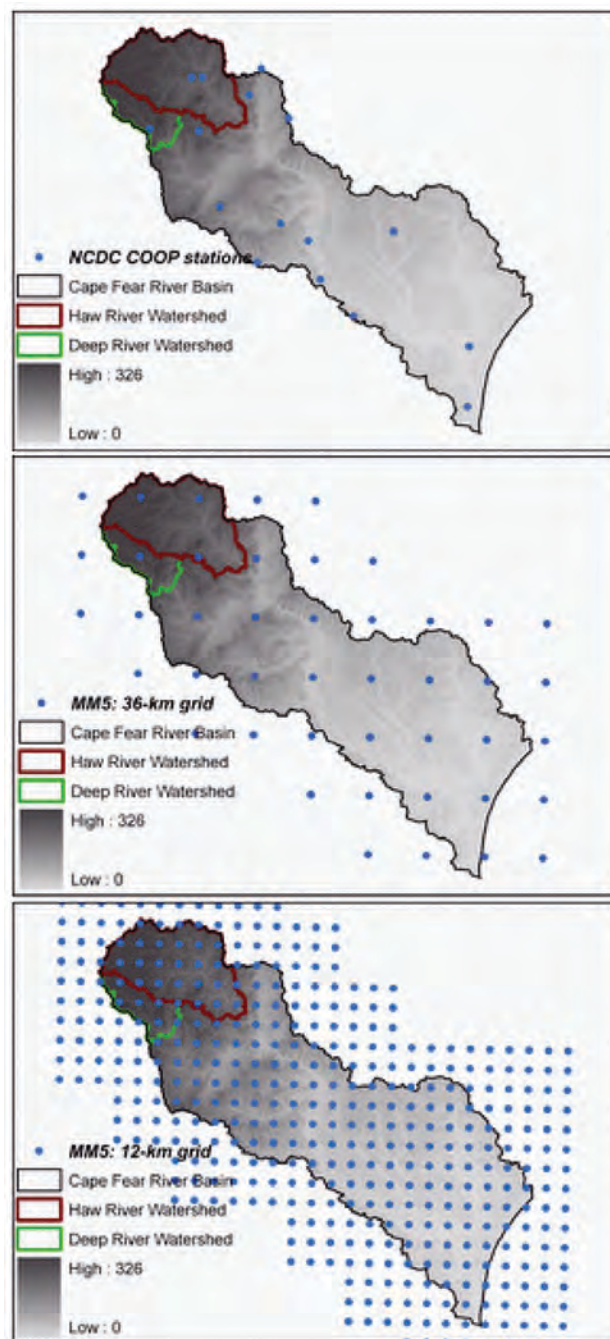

Figure 2. Comparison of the spatial resolutions of precipitation data in the Cape Fear River Basin: National Climatic Data Center observed precipitation sites (top), 36-km MM5 simulation grids (middle), and 12-km MM5 simulations grids (bottom). Each point on the MM5 grids is the centroid of the grid cell for which precipitation values are simulated.

Grid based mercury model

Rainfall-runoff evaluations are conducted using a recently developed spatially distributed grid-based watershed mercury (Hg) model (GBMM v2.0, Tetra Tech, 2006) that computes daily mass balances for hydrology, sediment, and mercury within each GIS raster grid cell and produces daily flux estimates of each to a tributary network.

GBMM implements a simple water balance to compute available soil water in the unsaturated zone (S_w ; cm) using the equation:

$$S_w = S_{w_o} + P_{tot} - R_o - ET - P_c$$

Where S_{w_o} is the initial water in the unsaturated zone (cm), P_{tot} is the total available water inputs at the soil surface (cm), R_o is the surface runoff (cm), ET is actual evapotranspiration (cm), and P_c is soil percolation (cm). Runoff is computed using a modified curve number approach, similar to SWAT (Neitsch et al. 2005), and ET derives from the Hamon formula for potential evapotranspiration (Hamon 1961). Precipitation from multiple stations is weighted using the Thiessen polygon method.

Initial calibration of the GBMM hydrology module (using a 90-m grid resolution) focused on daily discharge at six U.S. Geological Survey (USGS) stream gages and used daily observed precipitation from 15 NCDC stations within the Cape Fear River Basin to simulate runoff. However, because the length of model runs for the entire Cape Fear River Basin (16 hrs per run for a 24,144-km² watershed) was too time consuming for effective calibration, we completed the calibrations at a watershed in the upper basin (Deep River Watershed), comparing modeled runoff to discharge at USGS stream gage 02100500 (Deep River at Ramseur, NC) for 2001–2003. We used two NCDC stations (Randleman, Stn: 317097, and Siler City 2 N, Stn: 317924) for precipitation estimates in model calibration runs. Monthly—compared to daily—calibration results exhibited the best fit Nash-Sutcliffe and R^2 in the Deep River Watershed ($NS = 0.81$, $R^2 = 0.82$). Validation was conducted during the same period in the Haw River Watershed using USGS stream gage 02096960 (Haw River near Bynum) and five NCDC COOP precipitation sites: Siler City 2 N (Stn: 317924), Chapel Hill 2 W (Stn: 311677), Durham (Stn: 312515), Graham 2 ENE (Stn: 313555), and Burlington

Fire Station #5 (Stn: 311239). Monthly validation results for the Haw River Watershed were $NS = 0.83$ and $R^2 = 0.86$.

Parameter adjustments for model calibration were conducted using an automated parameter optimization method (OSTRICH; Matott 2005) with a global dynamically-dimensioned search (DDS) algorithm (Tolson and Shoemaker 2007) and a weighted sum of squared errors objective function. Subsequent trial-and-error parameter-fitting and calibration exercises were conducted to cross-check and complete this exercise.

Analysis

We used monthly calibration statistics to compare the modeled runoff results because (1) our model calibrated best using monthly statistics, and (2) our conceptual model of simulated rainfall data associates MM5 with a greater capacity to reflect broader temporal trends (i.e., monthly) rather than shorter, intense patterns of precipitation. Our initial analysis focuses on the effects of precipitation on runoff only; however, subsequent work will also concentrate on direct comparisons among variations in precipitation data sources and indices to correlate precipitation data directly with modeled runoff. Currently, we evaluate deviations in modeled runoff by introducing the two simulated data sets (12-km and 36-km MM5) into GBMM simulations.

We utilized the Nash-Sutcliffe efficiency index (Nash and Sutcliffe 1970) and R^2 to compare the monthly runoff statistics from the simulated runoff with observed runoff USGS stream gages 02100500–Deep River at Ramseur, NC, in the Deep River Watershed and 02096960–Haw River near Bynum, NC, in the Haw River Watershed. Further, we evaluated the effect of observed or simulated rainfall data on the timing and magnitude of peak discharge of the modeled runoff.

Preliminary Results and Discussion

The efficiency of modeled runoff resulting from the use of spatially-distributed precipitation data in GBMM decreased in both watersheds. For example, GBMM simulations using 12-km MM5 precipitation data suggest a decrease in runoff efficiency and goodness-of-fit ($NS = 0.49$, $R^2 = 0.54$) compared to GBMM simulations using observed precipitation data ($NS = 0.81$, $R^2 = 0.82$) (Figure 3A). Introduction of the coarser 36-km data into model runs results in a further

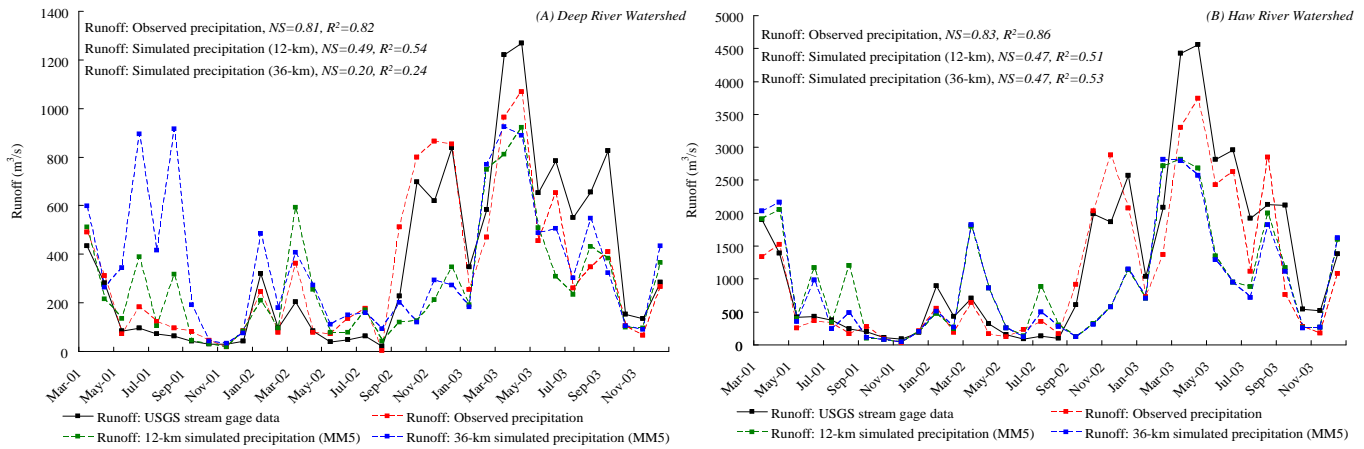

Figure 3. Comparison of modeled runoff from observed precipitation data, simulated MM5 12-km gridded precipitation data, and MM5 36-km gridded precipitation data in the Deep River Watershed (A) and the Haw River Watershed (B).

decline of both NS and R^2 ($NS = 0.20$, $R^2 = 0.24$). If only one watershed was analyzed, we might conclude that coarser resolution simulated data result in decreased runoff efficiency compared to finer resolution (12-km) data. However, the Haw River Watershed (Figure 3B) does not respond concomitantly. While both Nash-Sutcliffe and R^2 for monthly runoff decrease using both sets of simulated precipitation data, modeled runoff using the 12-km and 36-km data exhibits no difference in NS, and the coarser data has a slightly higher R^2 . Thus, although both 12-km and 36-km precipitation dramatically affect modeled runoff efficiency and goodness-of-fit in both watersheds, differences in the resolution of simulated data results in a nonuniform runoff response. Response to these variations is therefore watershed specific; however, physical characteristics, such as different sizes of the watersheds and flow alterations via dams and channelization, as well as model structure potentially influence modeled runoff variability. Further investigation is required to assess why such diverse response occurs. These steps are forthcoming in the next phase of the project.

Runoff simulations using the spatially-distributed precipitation data also suggest both missed peaks in discharge and early peak predictions. Simulations in both the Haw and Deep River Watersheds using the 12-km and 36-km modeled precipitation resulted in unexplained monthly peak runoff values considerably higher than stream gage data during June and September 2001, the representative dry year in the southeastern United States (Figure 3). Further, in the Haw River Watershed, simulations using both 12-km

and 36-km MM5 data predicted peaks in runoff a month earlier than that of stream gage data during the representative wet year (2003, March). While GBMM simulations using observed precipitation data underpredicted monthly peak runoff during the same period, temporal fluctuations in modeled runoff correspond to that of stream gage data. These findings correspond with our initial hypothesis that while simulated data improves the spatial density of precipitation estimates within mesoscale to large watersheds, these data do not capture the temporal variations in precipitation—and consequently, modeled runoff—as well as observed data. Although GBMM calibration was conducted using observed data, the goal of the long-term project is to assess how precipitation introduced from a variety of sources (e.g., a regional air quality model) affects water and contaminant loadings to and from watersheds. Thus, although we might expect data other than the observed precipitation to influence model behavior, our intent is to evaluate the extent to which this occurs.

The next phase of the project will incorporate additional precipitation data sets, including observation-resolved radar precipitation data from the National Multi-Sensor Precipitation Analysis (NPA; <http://wwwt.emc.ncep.noaa.gov/mmb/ylin/pcpanl>) and the Parameter-Elevations Regressions on Independent Slopes Model (PRISM) method (Daly et al. 2002). We will also include a validation year (2005) and develop indices for direct statistical comparisons among precipitation data sets and modeled runoff, similar to Andréassian et al. (2001). As part of this next phase, we will investigate how other precipitation data sets

used in regional air quality models affect simulated runoff and contaminant loadings from watersheds to surface water bodies. The initial results suggest that mass hydrological imbalances will occur, thus affecting chemical loadings to and from watersheds. Further research will evaluate the extent of the mass imbalances and implications for estimating and modeling watershed contaminant loading.

Acknowledgments

We appreciate manuscript reviews from Steve Kraemer and Molly Ramsey. We are also grateful to L. Shawn Matott for helpful assistance and the contribution of the OSTRICH parameter optimization program, and Steven Howard and Robert Gilliam for assistance with data extraction. This paper has been reviewed in accordance with the U.S. Environmental Protection Agency's peer and administrative review policies and approved for publication. Approval does not signify that the contents necessarily reflect the views and policies of the agency, nor does the mention of trade names or commercial products constitute endorsement or recommendation for use.

References

- Andréassian, V., C. Perrin, C. Michel, U.-S. Iolanda, and J. Lavabre. 2001. Impact of imperfect rainfall knowledge on the efficiency and the parameters of watershed models. *Journal of Hydrology* 250:206–223.
- Boyer, E., C. Goodale, N. Jaworski, and R. Howarth. 2002. Anthropogenic sources and relationships to riverine nitrogen export in the Northeastern USA. *Biogeochemistry* 57/58:137–169.
- Bullock, O.R., Jr., and K.A. Brehme. 2002. Atmospheric mercury simulation using CMAQ model: Formulation description and analysis of wet deposition results. *Atmospheric Environment* 36:2,135–2,146.
- Byun, D.W., and K.L. Schere. 2006. Review of the governing equations, computational algorithms, and other components of the Models-3 Community Multiscale Air Quality (CMAQ) modeling system. *Applied Mechanics Review* 59:51–77.
- Carpenter, T.M., and K.P. Georgakakos. 2004. Impacts of parametric and radar rainfall uncertainty on the ensemble streamflow simulations of a distributed hydrologic model. *Journal of Hydrology* 298:202–221.
- Daly, C., W.P. Gibson, G.H. Taylor, G.L. Johnson, and P. Pasteris. 2002. A knowledge-based approach to the statistical mapping of climate. *Climate Research* 22:99–113.
- Fekete, B.M., C.J. Vörösmarty, J.O. Roads, and C.J. Willmott. 2004. Uncertainties in precipitation and their impacts on runoff estimates. *Journal of Climate* 17:294–304.
- Grell, G.A., J. Dudhia, and D.R. Stauffer. 1995. A description of the fifth-generation Penn State/NCAR Mesoscale Model (MM5). National Center for Atmospheric Research, Technical Note NCAR/TN-398.
- Hamon, W.R. 1961. Estimating potential evapotranspiration. *Proceedings of the American Society of Civil Engineers, Journal of the Hydraulic Division* 87:107–120.
- Hossain, F., E.N. Anagnostou, T. Dinku, and M. Borga. 2004. Hydrological model sensitivity to parameter and radar rainfall estimation uncertainty. *Hydrological Processes* 18:3,277–3,291.
- Matott, L.S. 2005. OSTRICH: Optimization Software Tool. University at Buffalo, Buffalo, NY. [online] URL: <http://www.groundwater.buffalo.edu/software/Ostrich/OstrichMain.html>. Accessed 15 May 2009.
- MRLC (Multi-Resolution Land Cover - National Land Cover Database). 2001. National Land Cover Dataset 2001. [online]. URL: <http://www.mrlc.gov/nlcd.php>. Accessed 15 May 2009.
- Nash, J.E., and J.E. Sutcliffe. 1970. River flow forecasting through conceptual models, Part I: A discussion of principles. *Journal of Hydrology* 10:282–290.
- National Climatic Data Center. 2008. National Climatic Data Center online archive. National Atmospheric and Oceanic Administration, National Climatic Data Center. [online] URL: <http://www.ncdc.noaa.gov/oa/ncdc.html>. Accessed 15 May 2009.
- National Oceanic and Atmospheric Administration. 2008. U.S. Climate Division dataset mapping page. National Oceanic and Atmospheric Administration,

Earth System Research Laboratory. [online] URL:
<http://www.cdc.noaa.gov/USclimate/USclimdivs.html>.
Accessed 15 May 2009.

Neitsch, S.L., J.G. Arnold, J.R. Kiniry, and J.R. Williams. 2005. Soil and Water Assessment Tool: Theoretical Documentation, Version 2005. Grassland, Soil and Water Research Center, Agricultural Research Service and Blackland Research Center, Texas Agricultural Experiment Station, Temple, TX.

Tetra Tech. 2006. Development of Second-Generation of Mercury Watershed Simulation Technology: Grid-Based Mercury Model, Version 2.0, User's Manual. Tetra Tech, Fairfax, VA.

Tolson, B.A., and C.A. Shoemaker. 2007. Dynamically dimensioned search algorithm for computationally efficient watershed model calibration. Water Resources Research 43:W01413.

Post-Fire Watershed Response at the Wildland-Urban Interface, Southern California

Peter M. Wohlgemuth, Ken R. Hubbert, Jan L. Beyers, Marcia G. Narog

Abstract

In southern California, the unrelenting urban expansion into neighboring uplands has created a wildland-urban interface that is increasingly difficult to manage. In September 2002, the Williams Fire burned the San Dimas Experimental Forest (SDEF), mostly at high severity. This event provided an opportunity to describe and analyze the impacts of fire and the historical management practice of type-conversion on post-fire runoff, sediment yield, soil water repellency, and vegetation recovery in chaparral ecosystems at the wildland-urban interface.

Results indicate that soil water repellency increased with depth, declined with time since fire, was inversely related to soil moisture, and was only slightly different with the two pre-fire vegetation types. Herbaceous grasses and forbs dominated the post-fire vegetation initially, but all watersheds are reverting back to their pre-fire plant communities. Bare ground declined with time since fire, primarily as the litter layer accumulated. Number of species per watershed was similar with the two pre-fire vegetation types, although the species composition was different. Comparisons revealed similar magnitudes of post-fire watershed response for both pre-fire vegetation types. Runoff was large in the first post-fire year despite only moderate rainfall. Runoff exceeded the measurement equipment during

Wohlgemuth is a physical scientist, Beyers is a plant ecologist, and Narog is an ecologist, U.S. Department of Agriculture Forest Service–Pacific Southwest Research Station, Riverside Forest Fire Laboratory, Riverside, CA 92507. Hubbert is a soil scientist, U.S. Department of Agriculture Forest Service–Pacific Southwest Research Station, Sierra Nevada Research Center, Davis, CA 95616.

the record rainfall year of 2005. Sediment yield was large immediately after the fire but was negligible the following year. However, sediment yield was minor during the record rainfall year of 2005, suggesting that the supply of easily mobilized debris was depleted after the first post-fire winter. If there were any differences in fire behavior between the two vegetation types, the landscape exhibited nearly identical fire effects and watershed responses.

Summarizing results and their applications in an effective format remains the greatest challenge in communicating science to policy- and decisionmakers. For this project, the traditional technology transfer tools of written reports and symposia presentations were supplemented with field tours and a special workshop to which all local Federal, State, county, and municipal land managers, hazard protection agencies, and political administrators were invited.

Keywords: fire response, runoff, sediment yield, vegetation regrowth, nonwettable soils, management implications

Introduction

The unrelenting urban expansion into neighboring uplands in southern California has created a wildland-urban interface that is increasingly difficult to manage. Fire increases flooding and accelerated erosion that can adversely affect natural resources and downstream human communities. Wildfires coupled with heavy winter rains can threaten life, property, and infrastructure (roads, bridges, utility lines, communication sites), placing an extra burden on land managers who must be able to predict post-fire watershed response and mitigate against any potentially negative consequences to values at risk.

Fire is a major disturbance event in southern California environments that drives much of the surface erosion. The post-fire landscape is susceptible to dry season erosion (ravel) and raindrop splash with the removal of the vegetation cover (Rice 1974). Moreover, fire alters the physical and chemical properties of the soil (bulk density and water repellency) promoting surface runoff at the expense of infiltration (DeBano 1981). Post-fire water repellency (or nonwettability) has been shown to be spatially variable (Hubbert et al. 2006) and dependent on changes in soil moisture (Hubbert and Oriol 2005). The enhanced post-fire runoff removes more soil material from the denuded hillsides and can mobilize sediment deposits in the stream channels to produce debris flows with tremendous erosive power. Post-fire accelerated erosion eventually abates as the re-growing vegetation canopy and root system stabilizes the hillslopes and provides protection against the agents of erosion (Barro and Conard 1991).

In 1960 most of the San Dimas Experimental Forest (SDEF) burned in the Johnstone Fire. Following the fire, 25 small watersheds were instrumented with flumes and debris basins to measure runoff and sediment yield. The performance of selected mechanical and vegetative erosion control techniques—including type-conversion to perennial grasses—were evaluated against controls in these experimental catchments (Rice et al. 1965). In 2002 the SDEF burned again in the Williams Fire, including the area of this previous study that contained both type-converted and native chaparral watersheds. This second fire provided an opportunity to describe and analyze the impacts of fire and the historical management practice of type-conversion on post-fire runoff, sediment yield, soil water repellency, and vegetation recovery in chaparral ecosystems at the wildland-urban interface.

The San Dimas Experimental Forest

The SDEF is a nearly 7,000-ha research preserve administered by the U.S. Department of Agriculture Forest Service–Pacific Southwest Research Station and has been the site of extensive hydrologic monitoring for 75 years (Dunn et al. 1988). Established in 1933, the SDEF is located in the San Gabriel Mountains, about 45 km northeast of Los Angeles, CA (Figure 1). Elevations range from 450 to 1,700 m, and topography consists of a highly dissected mountain block with steep-walled canyons and steep channel gradients. Bedrock geology in the SDEF is dominated by

Precambrian metamorphics and Mesozoic granitics that produce shallow, azonal, coarse-textured soils (Dunn et al. 1988).

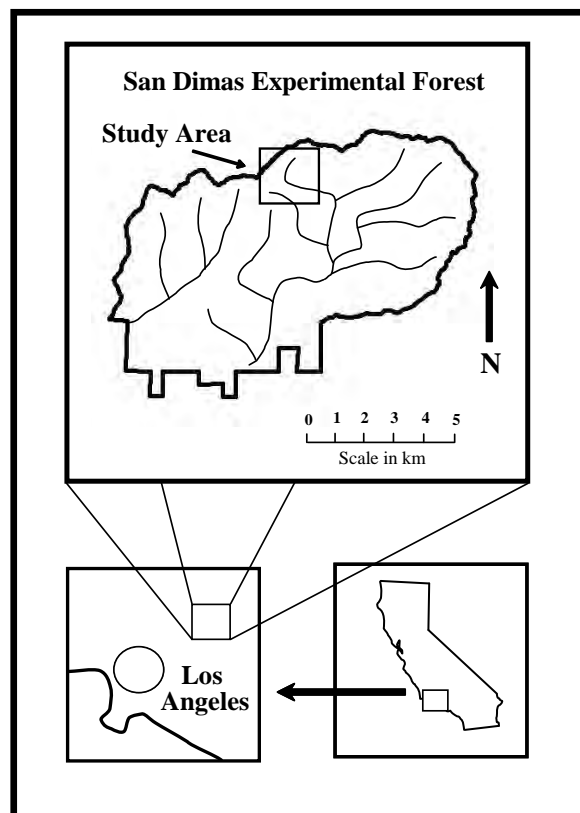

Figure 1. Location map of the San Dimas Experimental Forest.

The SDEF experiences a Mediterranean-type climate, characterized by hot, dry summers and cool, moist winters. Temperatures can range from -8°C to 40°C . Mean annual precipitation, falling almost exclusively as rain, is 714 mm (75-yr record), but rain during individual years can range from 252 to 1,898 mm. Over 90 percent of the annual precipitation falls between the months of November and April (Wohlgenuth 2006).

Native vegetation in the SDEF consists primarily of mixed chaparral. Plant cover on south-facing slopes ranges from dense stands of chamise (*Adenostoma fasciculatum*) and ceanothus (*Ceanothus* spp.) to more open stands of chamise and black sage (*Salvia mellifera*). North-facing hillsides are dominated by scrub oak (*Quercus berberidifolia*) and ceanothus, with occasional hardwood trees—live oak (*Quercus agrifolia*) and California laurel (*Umbellularia californica*)—occurring on moister shaded slopes and

along the riparian corridors (Wohlgemuth 2006). Pre-fire fuel loadings on the SDEF were 110–135 Mg ha⁻¹ (40–50 t ac⁻¹) (Ottmar et al. 2000).

Management treatments following the Johnstone Fire in 1960 involved the vegetation type-conversion of some native chaparral watersheds to a mixture of perennial grasses. It was thought that type-conversion would aid in future fire control and would enhance water yield (Rice et al. 1965). To assist in the grass establishment, regenerating shrubs were sprayed with herbicides. These perennials included a variety of wheatgrass species (*Agropyron* spp.), Harding grass (*Phalaris tuberosa* var. *stenoptera*), big bluegrass (*Poa ampla*), smilo grass (*Piptatherum miliaceum*), and blando brome (*Bromus hordaceous*) (Corbett and Green 1965). By 2002, substantial amounts of buckwheat (*Eriogonum fasciculatum*) and black sage had also established on the type-converted watersheds. Pre-fire fuel loadings on the converted watersheds were 14–27 Mg ha⁻¹ (5–10 t ac⁻¹) (Ottmar et al. 2000).

Following a winter drought and a hot, dry summer, the Williams Fire burned almost all of the SDEF in late September 2002. A smoke plume that rose almost vertically indicated an absence of wind, which allowed the fire to burn relatively slowly. The slow-moving fire permitted longer fire residence time that resulted in substantial soil heating. In most parts of the SDEF, the Williams Fire burned at moderate to high severity, consuming all the aboveground biomass and leaving only the skeletons of the largest stems (Napper 2002).

Methods

Following the 1960 Johnstone Fire, researchers selected replicate watersheds that were similar in size, shape, aspect, and potential erodibility. A trapezoidal flume to measure discharge and a debris basin to capture sediment was constructed in each catchment (Rice et al. 1965). Following the 2002 Williams Fire, we selected six of these small (1–3 ha) watersheds: three in native chaparral vegetation and three in type-converted grass. The stilling wells of the trapezoidal flumes were refurbished with a float and pulley water level recorder. The rating curves of the flumes were then used to compute flow discharge from stage height during the study period 2002–2006. Sediment yields were calculated using an engineering end-area formula (Eakin 1939) based on repeated sag tape surveys of permanent cross sections (Ray and Megahan 1978)

across the reservoirs. Surveys were conducted from 2002 to 2006. Precipitation was measured from throughout the study using the centrally-located SDEF master gage.

Vegetation was sampled for each of the six watersheds by first dividing each catchment into thirds (upper, middle, and lower sections). Three horizontal lines were randomly located across the entire watershed within each section. Ten 10-m line transects were randomly located along the horizontal lines in each section, yielding 30 transects per watershed. Plant cover by species was measured as centimeters covered along the 30 transects in each catchment. Vegetation was sampled from 2003 to 2006.

Soil water repellency was measured using the water drop penetration time (WDPT) method (Krammes and DeBano 1965). Twenty water drops were placed within a 30-cm-square area both at the mineral soil surface and at a depth of 2 cm. An additional 10 water drops were placed at a depth of 4 cm. Drop penetration time was measured with a stop watch and the times were aggregated to yield the following classification scheme: wettable, 0–5 seconds; slightly water repellent, 5–30 seconds; and moderate to highly water repellent, >30 seconds (Hubbert and Oriol 2005). Soil water repellency was measured twice a year, in late winter and in midsummer, from 2003 to 2006 repeatedly at 100 randomly chosen points within each pre-fire vegetation type. For every water repellency location, surface soil samples (0–5 cm) were taken in sealed tins and the ambient soil moisture was determined gravimetrically by oven drying (Gardner 1986).

Results

The soil water repellency testing produced a spectrum of results for each location. For comparison, the percentage of WDPT greater than 30 seconds was used to characterize water repellency at individual sites. Soil water repellency increased with depth and generally decreased with time since the fire (Table 1). Soil water repellency was also generally inversely related to soil moisture content (Table 1), exhibiting the seasonal fluctuations described by Hubbert and Oriol (2005). There appeared to be no clear relationships between soil water repellency and pre-fire vegetation type.

The study area was dominated by herbaceous plants (grasses and forbs) and bare ground for both pre-fire

Table 1. Rainfall, soils, vegetation, runoff, and erosion data by pre-fire vegetation and year.

Pre-fire vegetation Year	Native chaparral				Type-converted grass			
	2003	2004	2005	2006	2003	2004	2005	2006
Annual rainfall in millimeters ¹	615	408	1848	690	615	408	1848	690
Soil water repellency ²								
Winter								
Surface	3	NA	1	1	3	NA	1	0
2 cm	6	NA	21	4	8	NA	8	7
4 cm	8	NA	22	6	10	NA	6	5
Summer								
Surface	12	2	3	7	10	4	12	3
2 cm	39	12	10	15	43	20	41	4
4 cm	53	17	21	25	53	22	42	15
Soil moisture content ³								
Winter	13	NA	8	16	12	NA	8	14
Summer	1	1	2	2	1	1	1	1
Groundcover ⁴								
Grass	1	3	<1	3	18	31	13	13
Forbs	48	46	5	12	30	12	2	2
Sub-shrubs	3	8	26	19	5	14	32	29
Shrubs	10	11	18	27	4	3	9	9
Litter	0	17	39	27	0	19	31	35
Bare ground	38	15	12	12	43	21	13	12
Number of species ⁵	33	40	23	22	35	34	20	20
Peak discharge ⁶	15	2	51 ⁸	<1	26	6	49 ⁸	1
Sediment yield ⁷	43	0	6	2	32	0	5	0

¹Average annual rainfall is 714 mm (75 years of record).

²Average percent of drop penetration times greater than 30 seconds. N=100.

³Average percent by volume. N=100.

⁴Average relative percent by watershed. Forbs are herbaceous plants other than grasses. Sub-shrubs are drought-deciduous, semi-woody plants. N=3.

⁵Average by watershed. N=3.

⁶Average cubic meters per second per hectare (times 100). N=3.

⁷Average cubic meters per hectare. N=3.

⁸Minimum values (runoff exceeded the limits of the measurement equipment).

vegetation types the first year after fire (Table 1). By the third year, both the herbaceous cover and the amount of bare ground declined, as woody vegetation (shrubs and sub-shrubs) grew and litter accumulated. On the type-converted watersheds, grasses rebounded initially then declined in favor of sub-shrub species, such as buckwheat and black sage. All watersheds appeared to be reverting back to their pre-fire plant communities. The number of species per watershed was nearly identical between pre-fire vegetation types (Table 1), declining over time as the herbaceous community faded away. However, the actual species

composition on the two pre-fire vegetation types was different, although there was a good deal of overlap.

Post-fire watershed hydrologic response was measured by the normalized annual peak discharge ($\text{m}^3 \text{s}^{-1} \text{ha}^{-1}$). The results of the first year's measurements show large peak discharges—somewhat larger in the type-converted grass vegetation—despite only moderate rainfall (Table 1). Not surprisingly, peak discharge was even greater during the record rainfall year of 2005. Furthermore, these are minimum values, as the runoff exceeded the limits of the measurement equipment

during the largest storms. Peak discharge was negligible in 2006, despite the study area receiving more rain than in 2003.

Post-fire watershed erosion response was measured by the normalized annual sediment yields (m^3ha^{-1}). Results show that nearly all (85 percent) of the total sediment delivered to the debris basins over the course of the study came in the first year after the fire (Table 1). Slightly more sediment was generated by the native chaparral watersheds compared to those in type-converted grass vegetation. The record rainfall year of 2005 produced only minor erosion.

Discussion and Management Implications

Watershed conditions that would foster major runoff and erosion events in response to heavy rains include denuded hillsides and the presence of water repellent soils. These conditions were maximized during the first winter after the Williams Fire. In fact, large runoff and sediment yields were experienced on the SDEF in a year in which rainfall was only 86 percent of the long term average (Table 1).

Most of the sediment flushed out of these small watersheds over the duration of the study came in the first post-fire winter. This has huge implications for the establishment of emergency rehabilitation treatments. Whether on the hillslopes or in the stream channels, if mitigation measures are to be effective, they must be in place before the rainy season begins. However, their persistence or longevity after the first year appears to be considerably less critical.

The 2005 rainfall year was the wettest in 75 years of record keeping. The study area received more than an average year's worth of rain in one exceptional week. These storms produced tremendous runoff but generated only minor sediment yield. While the re-growing vegetation and accumulating litter layer had reduced the amount of bare ground to about 15–20 percent at the end of the previous growing season (Table 1), the watersheds would still be in a state of partial recovery only three years after the fire. An additional explanation is that the supply of easily-mobilized sediment was temporarily exhausted. Prior to the fire, sediment was delivered from the hillslopes to the ephemeral watercourses, where it accumulated in the channels. After the fire, more sediment was delivered to the channel networks, first by a pulse of dry

ravel and then by overland flow with the onset of the winter rains (Wohlgemuth 2006). Soil water repellency enhances this runoff. Consequently, more water is conveyed more quickly off the hillsides and into the stream channels, where it mobilizes the loose sediments and carries them to the debris basins. This flushing event scoured the channels of the easily-transportable ash and fine sediment, and the filling process began anew. Hence, when the record floods occurred two years later, little loose sediment was available for transport. Therefore, we suggest that watershed erosion recovery after a fire is not solely a function of vegetation regrowth, but also relates to the supply of easily-mobilized sediment.

The two different pre-fire vegetation types had very different fuel loadings and fuel structures. Presumably this would influence the fire behavior (rate of spread and residence time), which would in turn govern the fire severity (degree of consumption and soil alteration) and ultimately dictate watershed response (runoff and erosion). However, whether or not there were any differences in fire behavior between the two vegetation types, the landscape exhibited nearly identical fire effects and watershed responses (Table 1). This suggests that watershed response in southern California is perhaps more related to the regional factors of topography, soils, and the disposition of rainfall than to fire characteristics. Alternatively, fire behavior on both vegetation types may produce fire effects that are beyond some threshold which governs watershed response.

Communicating Science to Decisionmakers

Summarizing results and their applications in an effective format remains the greatest challenge in communicating science to policy- and decisionmakers. Managers and administrators are usually too busy to peruse the scientific literature, cull the salient points, and derive the management implications. On the other hand, researchers do not do enough to publicize their science, especially as it relates to applied problems. For this project, the traditional technology transfer tools of written reports and symposia presentations were supplemented with field tours and a special workshop. An initial field tour was held in October 2003 at the beginning of the study to announce the project, demonstrate methodologies, and get feedback from the attendees. A special workshop devoted to presenting

the results and management implications, along with an accompanying field tour, was held in May 2006. An invitation list was assembled that included all local Federal, State, county, and municipal land managers, hazard protection agencies (fire, flood control, public works), and political administrators who may have had even a remote interest in the project. Transportation from a central location and lunch were provided at no cost to the attendees. Although attendance at these events was less than we hoped (approximately 40 people each), the interaction and opportunities for one-on-one dialog was immensely satisfying to both the attendees and the conveners. This method of knowledge transfer proved to be an effective tool for both communicating science to decisionmakers and building professional relationships.

Acknowledgments

The authors appreciate the field assistance of Pete Robichaud and his crew for flume and instrument refurbishing. We also thank the dedicated technicians who labored heroically to collect the field data. This study was funded by the Joint Fire Science Program, Project Number 03-2-3-13.

References

- Barro, S.C., and S.G. Conard. 1991. Fire effects on California chaparral systems: An overview. *Environment International* 17:135–149.
- Corbett, E.S., and L.R. Green. 1965. Emergency revegetation to rehabilitate burned watersheds in southern California. U.S. Department of Agriculture, Forest Service, Research Paper PSW-22.
- DeBano, L.F. 1981. Water repellent soils: A state-of-the-art. U.S. Department of Agriculture, Forest Service, General Technical Report PSW-46.
- Dunn, P.H., S.C. Barro, W.G. Wells II, M.A. Poth, P.M. Wohlgenuth, and C.G. Colver. 1988. The San Dimas Experimental Forest: 50 years of research. U.S. Department of Agriculture, Forest Service, General Technical Report PSW-104.
- Eakin, H.M. 1939. Instructions for reservoir sedimentation surveys. In H.M. Eakin, ed., *Silting of Reservoirs*, pp. 153–164. U.S. Department of Agriculture, Technical Bulletin 524.
- Gardner, W.H. 1986. Water Content. In A. Klute, ed., *Methods of Soil Analysis*, pp. 493–544. American Society of Agronomy, Agronomy Monograph 9. Soil Science Society of America, Madison, WI.
- Hubbert, K.R., and V. Oriol. 2005. Temporal fluctuations in soil water repellency following wildfire in chaparral steepplands, southern California. *International Journal of Wildland Fire* 14:439–47.
- Hubbert, K.R., H.K. Preisler, P.M. Wohlgenuth, R.C. Graham, and M.G. Narog. 2006. Prescribed burning effects on soil physical properties and soil water repellency in a steep chaparral watershed, southern California, U.S.A. *Geoderma* 130:284–298.
- Krammes, J.S., and L.F. DeBano. 1965. Soil wettability: A neglected factor in watershed management. *Water Resources Research* 1:283–286.
- Napper, C. 2002. BAER Report, Williams Fire. U.S. Department of Agriculture, Forest Service, Angeles National Forest, FS-2500-8.
- Ottmar, R.D., R.E. Vihnanek, and J.C. Regelbrugge. 2000. Stereo photo series for quantifying natural fuels, vol. IV: Pinyon-juniper, chaparral, and sagebrush types in the Southwestern United States. PMS 883. National Wildfire Coordinating Group, Boise, ID.
- Ray, G.A., and W.F. Megahan. 1978. Measuring cross sections using a sag tape: A generalized procedure. U.S. Department of Agriculture, Forest Service, General Technical Report INT-47.
- Rice, R.M. 1974. The hydrology of chaparral watersheds. In *Proceeding of a Symposium on Living with the Chaparral*, Riverside, CA, 30-31 March 1973, pp. 27–34. Sierra Club, San Francisco, CA.
- Rice, R.M., R.P. Crouse, and E.S. Corbett. 1965. Emergency measures to control erosion after a fire on the San Dimas Experimental Forest. In *Proceedings of the Federal Inter-Agency Sedimentation Conference*, 28 January–2 February 1963, pp. 123–130. U.S. Department of Agriculture, Miscellaneous Publication 970.
- Wohlgenuth, P.M. 2006. Hillslope erosion and small watershed sediment yield following a wildfire on the San Dimas Experimental Forest, southern California. In *Proceedings of the Eighth Federal Interagency Sedimentation Conference*, 2-6 April 2006, Reno, NV, pp. 41–48. Advisory Committee on Water Information, Subcommittee on Sedimentation.

Hydrology, Biogeochemistry, and Ecology— Abstracts

Isotopic Signatures of Precipitation Quantify the Importance of Different Climate Patterns to the Hydrologic Budget: An Example from the Luquillo Mountains, Puerto Rico

M.A. Scholl, J.B. Shanley

Abstract

Precipitation isotopic signatures can help determine the relative importance of different climate patterns to the hydrologic balance and water supply of a region. Puerto Rico's climate is dominated by easterly trade winds, and the U.S. Geological Survey Water, Energy, and Biogeochemical Budget (WEBB) program's study area in the Luquillo Mountains receives substantial orographic precipitation. Global climate change, deforestation, or defoliation may cause a rise in cloud base altitude (ceiling height) by as much as a few hundred meters, leading to a decline in trade-wind orographic precipitation amounts. To help determine the importance of different precipitation types in the forest water cycle, nine rain collectors and three cloud water collectors were installed on a windward-leeward transect over the Luquillo Mountains. The collectors were sampled monthly for 3 years and precipitation was analyzed for $\delta^{18}\text{O}$ and $\delta^2\text{H}$. A seasonal cycle in rainfall isotopic composition was apparent, despite the small seasonal variation in temperature in Puerto Rico. Cloud height was correlated with measured precipitation isotopic composition using NEXRAD radar echo tops to help establish distinct isotopic signatures for the different types of precipitation. Precipitation with average isotopic values of -1.5‰ $\delta^{18}\text{O}$ and $+2.0\text{‰}$ $\delta^2\text{H}$ was associated with the dry season weather pattern of orographic uplift and trade wind showers. Wet season precipitation, mostly convective rainfall associated with easterly waves, had average values of -3.6‰ $\delta^{18}\text{O}$ and -16‰ $\delta^2\text{H}$. Trade-wind orographic precipitation usually occurs as frequent, low-intensity, and low-volume rain events, whereas convective and low-pressure systems have higher volume and more intense rainfall. Isotopic composition of stream water at higher altitudes in the Icacos and Mameyes watersheds suggests that the orographic rain events are more important than convective events in maintaining stream base flow. High-intensity rain events run off quickly and may not effectively infiltrate the saturated, low-permeability tropical soils. Weather analysis showed that 29 percent of rain input to the Luquillo Mountains was trade-wind orographic rainfall, and 30 percent of rainfall could be attributed to easterly waves and low pressure systems. Isotopic signatures associated with these major climate patterns can be used to determine their relative importance to streamflow and groundwater recharge.

Scholl and Shanley are research hydrologists with the U.S. Geological Survey, Reston, VA, and Montpelier, VT, respectively. Email: mascholl@usgs.gov; jshanley@usgs.gov.

Mercury Cycling Research Using the Small Watershed Approach

Jamie Shanley, Ann Chalmers

Abstract

Researchers increasingly recognize the importance of terrestrial uplands to mercury biogeochemistry. Terrestrial area dominates the landscape and forest canopies scavenge atmospheric mercury. As a result, terrestrial landscapes are a large source of total mercury to down gradient aquatic ecosystems where methylation is known to occur. Methylmercury is the form of mercury that bioaccumulates in invertebrates and fish, i.e. food consumed by wildlife and humans. Methylmercury may also form in uplands and directly enter the food web. The small watershed approach is well suited to unraveling the processes controlling mercury retention, transformation, and transport to down-gradient aquatic ecosystems. Accurate watershed mass balance quantifies retention of total mercury and the role of atmospheric inputs as a methylmercury source. Process research at a small scale and high temporal frequency identifies hot spots of mercury methylation and hot moments of mercury export. We discuss insights on mercury cycling learned from the small watershed approach at Sleepers River, VT, and other U.S. Geological Survey Water, Energy, and Biogeochemical Budgets (WEBB) watersheds, as well as examples from other U.S. and European watersheds.

Shanley and Chalmers are both hydrologists at the Vermont Office of the U.S. Geological Survey New Hampshire–Vermont Water Science Center, Montpelier, VT. Email: jshanley@usgs.gov; chalmers@usgs.gov.

Hydrology, Biogeochemistry, and Ecology— Manuscripts

Soil Evaporative Response to Lehmann Lovegrass *Eragrostis lehmanniana* Invasion in a Semiarid Watershed

M.S. Moran, E.P. Hamerlynck, R.L. Scott, W.E. Emmerich, C.D. Holifield Collins

Abstract

Across the western United States, warm-season grasslands are being invaded by the exotic perennial grass *Eragrostis lehmanniana* (Lehmann lovegrass). The objective of this study was to quantify the change in surface water balance associated with *E. lehmanniana* invasion. Following a protracted drought, the Kendall grassland in the USDA-ARS Walnut Gulch Experimental Watershed (WGEW) in southeast Arizona transitioned from a native bunchgrass community to one dominated by *E. lehmanniana*. A network of microlysimeters was deployed at Kendall to measure daily soil evaporation (E_D), and an empirical model was developed to predict E_D based on soil moisture (θ) measured at 5 cm depth and average daily solar radiation (L). Results confirmed that total evapotranspiration over the growing season (ET_S) was a function of season-long infiltration (I_S) regardless of vegetation type, where ET_S/I_S was close to one. For years of similar precipitation patterns and ET_S/I_S , the contribution of evaporation E to ET for the growing season (E_S/ET_S) doubled with the invasion of *E. lehmanniana*. These results are a first step toward understanding the initiation and persistence of *E. lehmanniana* invasion.

Keywords: invasive grasses, ecohydrology

Moran, Hamerlynck, Scott, Emmerich and Holifield Collins are Research Scientists with the USDA-ARS Southwest Watershed Research Center, 2000 E. Allen Rd., Tucson, AZ 85719. Emails: susan.moran@ars.usda.gov; erik.hamerlynck@ars.usda.gov; russ.scott@ars.usda.gov; bill.emmerich@ars.usda.gov; Chandra.holifield@ars.usda.gov.

Introduction

The invasion of the exotic grass, *Eragrostis lehmanniana* (Lehmann lovegrass) into native desert grasslands is of great concern to ranchers and land managers throughout the Southwestern United States. *Eragrostis lehmanniana* produces a near monoculture that displaces native grasses and in recent years has expanded over a substantial portion of semiarid grasslands of the desert southwest (McClaran and Anable 1992). The ecological effects of *E. lehmanniana* invasion have been well documented in studies showing that *E. lehmanniana* dominance is associated with dramatically reduced plant and animal diversity (Jones and Bock 2005). *Eragrostis lehmanniana* is also less sensitive to grazing and fire than most native grasses, and this disturbance tolerance may facilitate long-term persistence and dominance of *E. lehmanniana* in desert grasslands (McClaran and Anable 1992). There is far less known about the impact of *E. lehmanniana* invasion on ecosystem hydrology, despite the fact that it is a common invasive species in the desert southwest where water is scarce. *Eragrostis lehmanniana* can have smaller plant basal areas yet higher plant densities than native bunchgrasses, resulting in little change in grass biomass compared to pre-invasion levels. Consequently, it is difficult to determine if *E. lehmanniana* invasion will affect ecosystem water balance, and if so, if it will cause an increase or decrease in total season-long evapotranspiration (ET_S), soil evaporation (E_S), and (or) plant transpiration (T_S).

The goal of this study was to use multiyear measurements of a naturally occurring vegetation transition to quantify the change in surface water balance, particularly soil evaporative response, associated with *E. lehmanniana* invasion. Specifically, the objectives were to determine (1) the variability that

can be expected in E_s/ET_s with a native-to-exotic grassland transition, and (2) the key processes that control this variability. A basic premise of this study was that seasonal E_s/ET_s during the native-to-exotic grassland transition is largely a function of the variability in precipitation and the vegetation, and that the impact of these two factors on E_s/ET_s could be decoupled by analysis of measurements made throughout the multiyear transition.

Methods

The study was conducted in the Kendall grassland in southeast Arizona (Renard et al. 2008), which shifted from a grassland dominated by the native bunchgrass *Bouteloua eriopoda* (Torr.) Torr. (black grama) in 2005 to near complete dominance by the exotic *E. lehmanniana* in 2007.

Precipitation, runoff, and meteorological conditions have been recorded at Kendall over the past decade (Goodrich et al. 2008, Stone et al. 2008, Keefer et al. 2008). Precipitation is measured with a weighing-type recording raingage, and runoff is measured with a V-notched weir for the small Kendall subwatershed. Daily infiltration (I_D), defined as the total equivalent depth of water that enters the soil, was computed by subtracting daily runoff from daily precipitation (units of length). These values were then summed to compute a season total value (I_S). Average daily solar radiation (L_D) was computed as the average of incoming solar radiation measurements over the daylight period, generally from 8 a.m. to 6 p.m. during the growing season (W/m^2). This value was then averaged to compute a seasonal value (L_S).

From 1997 through 2007, a Bowen ratio system was on site to measure diurnal ET at 20-min intervals, summed to give a value of daily ET_D (Emmerich and Verdugo 2008). The Bowen ratio system was placed near the meteorological station with a fetch of 200+ m in all directions. In 2005, a network of 20 microlysimeters (ML) were installed at Kendall to measure E_D (Green 2006). Microlysimeters of 76-mm diameter and 30-cm depth were installed in a cross-shaped pattern centered on the Bowen ratio system over an area of 60 x 60 m. Daily E_D was measured manually on days between rainfall events during the vegetation growing season in 2005 (Green 2006) and for a more limited time in 2007.

The net ecosystem exchange of carbon dioxide (NEE) was also measured at Kendall using a Licor 7500 open path CO_2/H_2O analyzer. NEE represents the respiration by microorganisms and plants that release CO_2 to the atmosphere and the fixation of CO_2 that occurs during photosynthesis, where the latter is associated with the concurrent water loss due to T. The notation used in this paper was adopted from that presented by Kurc and Small (2007), where positive values of NEE correspond to net respiration over 24 hours (NEE_D^+) and negative values of NEE correspond to net assimilation over 24 hours (NEE_D^-).

The trends of NEE_D (not shown) were used to discriminate three analysis periods. The “growing season” was the time period when perennial plants were likely to be green and transpiring **and** the majority of the North American Monsoon (NAM) precipitation was encompassed: days 180–315. The “early season” was defined as the period when NEE_D was generally positive, precipitation was increasing from the dry June period, and T_D could be assumed to be low allowing E_D to reach a maximum: days 180–214. The “mid season” was defined as the period when NEE_D was likely to be negative at some point, plants had received sufficient precipitation to be actively transpiring, and T_D could be assumed to reach a maximum: days 215–285.

From 2003 to the present, volumetric soil moisture (θ) has been measured at Kendall at two depths (5 and 15 cm) at 20- to 30-min intervals with Stevens Hydra Probe sensors (Keefer et al. 2008). The sensors were located close to the Bowen ratio system and centered within the 60 x 60 m network of microlysimeters. Soil moisture measured at 5 cm (θ_5) was assumed to characterize the surface soil moisture from 0 to 5 cm.

Hydrological and ecological conditions

This multiyear investigation was designed to allow discrimination of the change in E_s/ET_s associated with the influences of annual precipitation patterns and vegetation type. The first step was to identify years of similar vegetation and hydrology that could be compared and contrasted in further analysis (Table 1).

Vegetation measurements showed that for years 2002–2005 the vegetation cover was dominated by *B. eriopoda* (King et al. 2008). Year 2006 was a “transition” year in which *B. eriopoda* experienced a drastic die-off, the *E. lehmanniana* was increasing its

presence, and the annual forbs represented the dominant vegetation cover. By year 2007, the vegetation cover was dominated by *E. lehmanniana*. This groups the years into those dominated by *B. eriopoda* (2002–2005), by forbs (2006), and by *E. lehmanniana* (2007).

A basic assumption underlying this study is that ET_S/I_S over the water year at Kendall would be greater than or close to one regardless of vegetation differences (Table 1). For years when infiltration was at or above the 30-yr average (215 mm/yr), ET_S/I_S was only slightly greater than one (1.06). For years when infiltration was below the 30-yr average, ET_S/I_S increased with decreasing I_S according to the function

$$ET_S/I_S = (-2.34 \times 10^{-3}) + 1.62(I_S) \{r^2=0.77\}.$$

Over the period from 2002 to 2007, there are only two years that were hydrologically similar: years 2002 and 2007. They had nearly identical I_S , minimum NEE_D , and ET_S/I_S (Table 1). All other years were determined to have exclusive hydrologic patterns. Years 2005 and 2006 were the polar extremes, where year 2006 had substantially more precipitation than any other year and year 2005 had substantially less. Years 2003 and 2004 had similar total precipitation but it was distributed differently, where precipitation in year 2003 was distributed evenly throughout the growing season, and the precipitation pattern in year 2004 was bi-modal resulting in a strongly bi-modal trend in NEE_D .

Table 1. Comparison of vegetation and hydrological conditions over the growing season (days 180–315). Veg refers to the dominant vegetation type (*B.e.* is *B. eriopoda* and *E. l.* is *E. lehmanniana*), ET_S/I_S refers to the ratio of seasonal evapotranspiration (ET_S) and infiltration (I_S); NEE_{min} is the minimum daily net ecosystem exchange over the growing season; and the last two columns indicate if the vegetation and precipitation patterns were considered similar.

Year	Veg	ET_S/I_S	I_S	NEE_{min}	Veg sim?	Pcp sim?
2002	<i>B. e.</i>	1.16	178	-29	√	√
2003	<i>B. e.</i>	1.32	114	-9	√	
2004	<i>B. e.</i>	1.25	154	-9	√	
2005	<i>B. e.</i>	1.43	91	-15	√	
2006	forbs	1.06	219	-30		
2007	<i>E. l.</i>	1.18	175	-31		√

Results and Discussion

The stated objectives of this study were to determine (1) the variability that can be expected in E/ET with a native-to-exotic grassland transition, and (2) the key processes that control this variability. Analysis of data was conducted in several steps. First, the measurements made with microlysimeters in 2005 (pre-invasion) and 2007 (post-invasion) were used to develop an empirical model to estimate E_D from measurements of θ_5 and L_D throughout the season for all years (2002–2007). These estimates of season-long E_D and concurrent measurements of ET_D made it possible to investigate the trends in E_D/ET_D that could be expected with different precipitation patterns and vegetation types. Finally, we were able to use the seasonal E_S/ET_S estimates to determine the impact of *E. lehmanniana* invasion on ecosystem water balance.

E_D from microlysimeter measurements

The ML measurements offered the opportunity to develop an empirical model of ET_D based on the assumptions that soil evaporation occurs at shallow depths (5–15 cm) and varies with available energy (Loik et al. 2004). A regression was fit to ML measurements of E_D and midday measurements of θ_5 (Figure 1A). Similarly, the relation between ML measurements of E_D and L_D was explored, but there was no significant relation for the days of ML measurements when values of L_D were greater than 400 W/m^2 (Figure 1B). As a result, it was possible to predict E_D from θ_5 and L_D using an equation derived from multiple regression,

$$E_D = (8.78 \times 10^{-2}) + (11.66)\theta_5 - (1.02 \times 10^{-4})L_D \quad (1)$$

with $r^2=0.91$, where Equation 1 could be applied to days with $L_D > 400 \text{ W/m}^2$.

The comparison of E_D modeled with Equation 1 versus E_D measured with ML offers an indication of the error one might expect in application of the model to other years, assuming the measurements of θ_5 and L_D continue to be accurate and the relation in Equation 1 holds over several years for the Kendall site. The mean absolute difference (MAD) between the modeled and measured E_D was only 0.3 mm/d and the values clustered around the 1:1 line in Figure 1C. Given this good fit, Equation 1 was used to estimate E_D for years

2002–2007 for further analysis in the following sections.

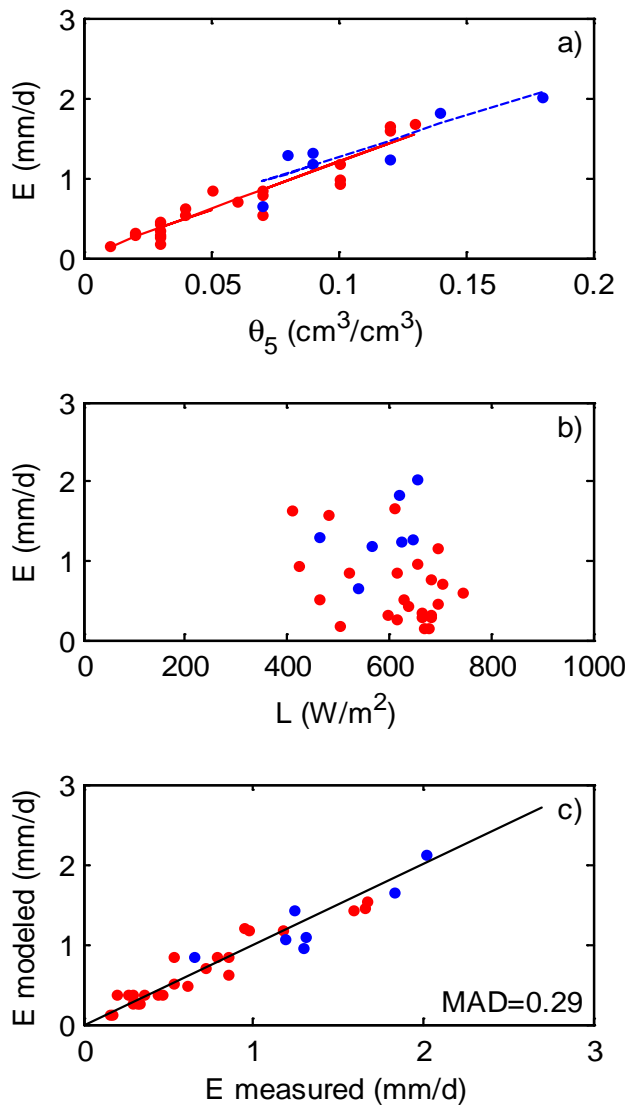

Figure 1. The relations between E_D measured with microlysimeters versus (A) soil moisture at 5 cm depth (θ_5), (B) average daily solar radiation (L_D), and (C) E_D modeled with θ_5 and L_D .

Maximum E_D/ET_D and T_D/ET_D

Results demonstrated that E_D and T_D reach a maximum value that was a linear function of ET_D (not shown here). By selecting the $\{E_D, ET_D\}$ and $\{T_D, ET_D\}$ data pairs associated with the left edge of the E_D and T_D versus ET_D relations, it was possible to determine the maximum E_D/ET_D and T_D/ET_D for the early and mid seasons for each study year (Figure 2). This is

expressed as a general linear form $\{y=a+bx\}$ by Guswa et al. (2002) that was fit to Kendall data as follows:

$$\text{Maximum } E_D = aET_D, \text{ and} \quad (2)$$

$$\text{Maximum } T_D = ET_D - b, \quad (3)$$

where a and b are coefficients determined by regressions illustrated in Figure 2. For Equation 2, the intercept of the linear relation between E_D and ET_D was near zero, as expected. For Equation 3, the slope of the relation between T_D and ET_D was near one and the intercept b was related to the minimal value of E_D for the season.

For years 2002–2004, when precipitation was slightly below normal and vegetation cover was dominated by *B. eriopoda*, values of maximum E_D/ET_D were similar (maximum $E_D/ET_D = 0.41$) (Figure 2A). For all other years maximum E_D/ET_D was higher, indicating an increase in E_D during the early season when precipitation is extremely low (maximum $E_D/ET_D = 0.60$ in 2005) or when vegetation has changed (maximum $E_D/ET_D = 0.51$ in 2007). The results for year 2006 are difficult to interpret because there was a simultaneous change in both precipitation pattern and vegetation type.

Values of maximum T_D/ET_D were similar for years 2002–2006, where maximum $T_D = ET_D - 0.3$ mm/d with a MAD of 0.09 mm/d (Figure 2B). This can be interpreted to mean that the minimum value of E_D during the mid-season in all years was close to 0.3 mm/d. This was similar to the value derived from the ML data for Kendall in 2005 by Moran et al. (2008). However, maximum T_D/ET_D in 2007 was strikingly different from all other years, where maximum $T_D = ET_D - 0.77$ mm/d (MAD=0.09 mm/d). This means that the minimum value of mid-season E_D was more than double that estimated for any other year in the study. This could be explained by the distribution of root biomass at Kendall. Cox et al. (1986) reported that 70 percent of the fine root biomass at Kendall was between 0 and 6 inches in year 1983. Assuming the same vegetation persisted in years 2002–2005 (according to King et al. 2008), this root biomass was sustained until 2006 when the relative dominance of *B. eriopoda* decreased to zero and the cover was dominated by annual forbs. With the invasion of *E. lehmanniana* in 2007, much of the *B. eriopoda* root biomass was dead and perhaps not replaced with similar biomass during the early period of

E. lehmanniana establishment. It may also be explained by differences in leaf area index (not measured in this study). Huxman et al. (2004) hypothesized that lower LAI in *E. lehmanniana* plots may promote higher soil temperatures, which would favor the evaporation of soil water rather than infiltration following rain events.

Growing season E_s/ET_s

A basic ecohydrological question was posed in the introduction: Does *E. lehmanniana* invasion affect ecosystem water balance, and if so, will it cause an increase or decrease in ET_s , E_s , and (or) T_s ? A preliminary answer can be found by comparing the evaporative response over the entire growing season (days 180–315) in years 2002 and 2007, when precipitation patterns were similar but vegetation was not. First, the ET_s and ET_s/I_s in 2002 and 2007 were nearly identical, despite the dramatic vegetation transition (Table 1). However, results show that the partitioning of E_s and T_s was greatly changed. Apparently, the rapid transition from an established native grassland dominated by *B. eriopoda* to a new stand dominated by the exotic *E. lehmanniana* has caused maximum E_D/ET_D to increase and maximum T_D/ET_D to decrease substantially (Figure 2). As a result, E_s/ET_s over the growing season was twice as high in 2007 than in 2002, while both years had average precipitation and similar precipitation patterns (Figure 3).

Conclusions

This study investigated the variability that can be expected in E/ET with *E. lehmanniana* invasion and the key processes that control this variability. Preliminary conclusions drawn from observations over six years in the Kendall semiarid grassland were:

1. The transitions from *B. eriopoda* to *E. lehmanniana* did not affect ET_s/I_s over the growing season.
2. Maximum daily E_D/ET_D was influenced by both precipitation patterns and vegetation type; maximum daily T_D/ET_D was influenced by vegetation type but not precipitation patterns.
3. Regarding the basic question about whether *E. lehmanniana* invasion would cause an increase or decrease in E_s , results showed that E_s/ET_s over the growing season doubled during years of average precipitation and similar precipitation pattern (i.e., 2002 and 2007).

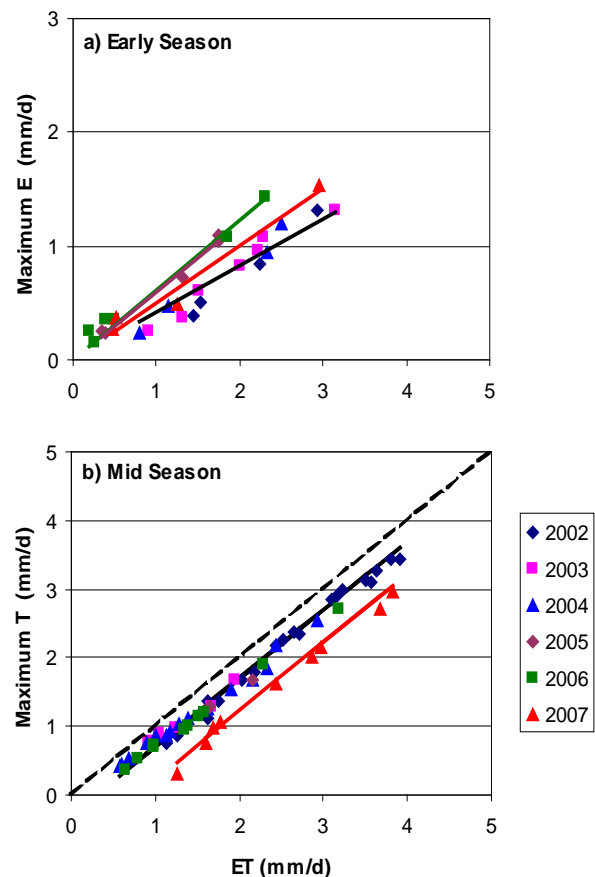

Figure 2. The maximum (A) E_D/ET_D and (B) T_D/ET_D for the early and mid seasons (respectively) for study years 2002–2007. The solid lines represent (A) maximum $E_D = aET_D$ and (B) maximum $T_D = ET_D - b$, and the dashed line is the 1:1 line for T_D/ET_D .

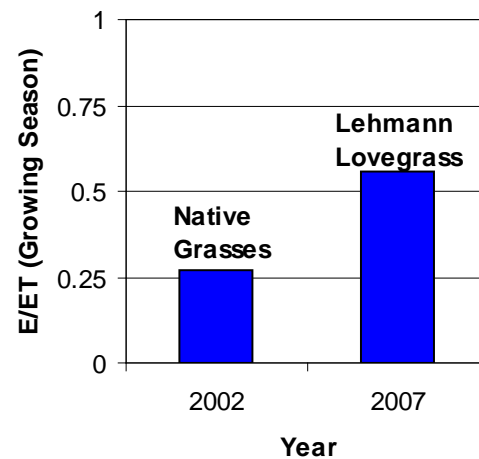

Figure 3. Values of E_s/ET_s over the growing season (days 180–315) in 2002 (pre-invasion) and 2007 (post-invasion) for years of average precipitation and similar precipitation patterns (Table 1).

Acknowledgments

This work was partially funded by the NASA/USDA Soil Moisture Experiment (SMEX04) led by Dr. Thomas Jackson, USDA–ARS Hydrology and Remote Sensing Laboratory, Beltsville, MD. We depended heavily on the staff at Walnut Gulch Experimental Watershed led by John Smith to keep the instrumentation running and calibrated for this multi-year analysis.

References

- Cox, J.R., G.W. Frasier, and K.G. Renard. 1986. Biomass distribution at grassland and shrubland sites, *Rangelands* 8:67–69.
- Emmerich, W.E., and C.L. Verdugo. 2008. [Precipitation thresholds for CO₂ uptake in grass and shrub plant communities on Walnut Gulch Experimental Watershed](#). *Water Resources Research* 44:W05S16.
- Goodrich, D.C., T.O. Keefer, C.L. Unkrich, M.H. Nichols, H.B. Osborn, J.J. Stone, and J.R. Smith. 2008. [Long-term precipitation database, Walnut Gulch Experimental Watershed, Arizona, United States](#). *Water Resources Research* 44:W05S04.
- Green, K.N. 2006. Partitioning of evapotranspiration in a Chihuahuan desert grassland. University of Arizona, Department of Hydrology and Water Resources. M.S. Thesis. Tucson, AZ. 102 p.
- Guswa, A.J., M.A. Celia, and I. Rodriguez-Iturbe. 2002. Models of soil moisture dynamics in ecohydrology: A comparative study. *Water Resources Research* 38:1–15.
- Huxman, T.E., J.M. Cable, D.D. Ignace, J.A. Eilts, N.B. English, J. Weltzin, and D.G. Williams. 2004. Response of net ecosystem gas exchange to a simulated precipitation pulse in a semi-arid grassland: The role of native versus non-native grasses and soil texture. *Oecologia* 141:295–305.
- Jones, Z.F., and C.E. Bock. 2005. The Botteri's sparrow and exotic Arizona grasslands: An ecological trap or habitat regained? *The Condor* 107:731–741.
- Keefer, T.O., M.S. Moran, and G.B. Paige. 2008. [Long-term meteorological and soil hydrology database, Walnut Gulch Experimental Watershed, Arizona, United States](#). *Water Resources Research* 44:W05S07.
- King, D., S. Skirvin, C. Holifield Collins, M.S. Moran, S. Biedenbender, M. Kidwell, M.A. Weltz, and A. Diaz-Guiterrez. 2008. [Assessing vegetation change temporally and spatially in southeastern Arizona](#). *Water Resources Research* 44:W05S15.
- Kurc, S.A., and E.E. Small. 2007. Soil moisture variations and ecosystem-scale fluxes of water and carbon in semiarid grassland and shrubland. *Water Resources Research* 43:1–15.
- Loik, M.E., D.D. Breshears, W.K. Lauenroth, and J. Belnap. 2004. A multi-scale perspective of water pulses in dryland ecosystems: Climatology and ecohydrology of the western USA. *Oecologia* 141:269–281.
- McClaran, M.P., and M.E. Anable. 1992. Spread of introduced Lehmann lovegrass along a grazing intensity gradient. *Journal of Applied Ecology* 29:92–98.
- Moran, M.S., R.L. Scott, T.O. Keefer, M. Hernandez, G.S. Nearing, W.E. Emmerich, G.B. Paige, M.H. Cosh, and P.E. O'Neill. 2008. Partitioning evapotranspiration in semiarid grassland and shrubland ecosystems using time series of soil surface temperature. *Agricultural and Forest Meteorology* 149(1):59–72.
- Renard, K.G., M.H. Nichols, D.A. Woolhiser, and H.B. Osborn. 2008. [A brief background on the U.S. Department of Agriculture Agricultural Research Service Walnut Gulch Experimental Watershed](#). *Water Resources Research* 44:W05S02.
- Stone, J.J., M.H. Nichols, D.C. Goodrich, and J. Buono. 2008. [Long-term runoff database, Walnut Gulch Experimental Watershed, Arizona, United States](#). *Water Resources Research* 44:W05S05.

Using a Coupled Groundwater/Surface-Water Model to Predict Climate-Change Impacts to Lakes in the Trout Lake Watershed, Northern Wisconsin

John F. Walker, Randall J. Hunt, Steven L. Markstrom, Lauren E. Hay, John Doherty

Abstract

A major focus of the U.S. Geological Survey's Trout Lake Water, Energy, and Biogeochemical Budgets (WEBB) project is the development of a watershed model to allow predictions of hydrologic response to future conditions including land-use and climate change. The coupled groundwater/surface-water model GSFLOW was chosen for this purpose because it could easily incorporate an existing groundwater flow model and it provides for simulation of surface-water processes.

The Trout Lake watershed in northern Wisconsin is underlain by a highly conductive outwash sand aquifer. In this area, streamflow is dominated by groundwater contributions; however, surface runoff occurs during intense rainfall periods and spring snowmelt. Surface runoff also occurs locally near stream/lake areas where the unsaturated zone is thin. A diverse data set, collected from 1992 to 2007 for the Trout Lake WEBB project and the co-located and NSF-funded North Temperate Lakes LTER project, includes snowpack, solar radiation, potential evapotranspiration, lake levels, groundwater levels, and streamflow. The time-series processing software TSPROC (Doherty 2003) was used to distill the large time series data set to a smaller set of observations and summary statistics that captured the salient hydrologic information. The time-series processing reduced hundreds of thousands of observations to less than 5,000. Model calibration included specific predictions for several lakes in the study area using the PEST parameter estimation suite of software (Doherty 2007). The calibrated model was used to simulate the hydrologic response in the study

lakes to a variety of climate change scenarios culled from the IPCC Fourth Assessment Report of the Intergovernmental Panel on Climate Change (Solomon et al. 2007). Results from the simulations indicate climate change could result in substantial changes to the lake levels and components of the hydrologic budget of a seepage lake in the flow system. For a drainage lake lower in the flow system, the impacts of climate change are diminished.

Introduction

Although groundwater and surface water are generally considered a single resource, simulations involving this single resource commonly do not explicitly couple the two systems. Moreover, models used to evaluate the effects of climate variability often approximate one of the two systems, even though interaction with the other might be important. A more holistic view is to include both the groundwater and surface-water systems. Groundwater and surface-water models can be loosely linked outside of the models (e.g., Hunt and Steuer 2000, Steuer and Hunt 2001), but often only time-averaged/long-term simulations are tractable, which may not include enough interannual characteristics and related system dynamics to be optimal. Coupled hydrologic models, on the other hand, can include various hydrologic feedback pathways and thus more fully encompass the processes and related dynamics that may augment or mitigate the effect of hydrologic stress. These processes include the timing and rates of evapotranspiration, surface runoff, soil-zone flow, and interactions between the surface-water and groundwater systems.

Coupled models can use a fully integrated approach but, because this type of coupling is based on a three-dimensional Richards' equation, they require a much finer spatial grid and smaller time steps than typically are used to simulate saturated hydrologic flows (Markstrom et al. 2008). The high computational requirements limit their applicability for simulating watershed scale flow over societally relevant time periods (years to tens of years). An efficient alternative to a fully integrated coupled model is to simulate unsaturated flow assuming that dominant direction of flow within the unsaturated zone is vertical when averaged over the grid scale typical of a watershed model (Niswonger et al. 2006). Using this type of approximation, equations can be formulated to simulate flow and storage in the various regions/compartments (i.e., soil, unsaturated, and saturated zones) with the goal of attaining some compromise between model efficiency and model accuracy. This "coupled regions" approach was implemented in the recently released code GSFLOW (Groundwater/Surface-water FLOW) model (Markstrom et al. 2008). GSFLOW is an

integration of the USGS Precipitation-Runoff Modeling System (PRMS; Leavesley et al. 1983, Leavesley et al. 2005) with the 2005 version of the USGS Modular Groundwater Flow Model (MODFLOW-2005; Harbaugh 2005).

In GSFLOW, separate equations are coupled to simulate horizontal and vertical flow through the soil zone, gravity-driven vertical flow through the unsaturated zone, and three-dimensional groundwater flow through the saturated zone. GSFLOW was designed to simulate the most important processes using a numerically efficient algorithm, thus allowing coupled simultaneous simulation of flow in and across one or more watersheds. GSFLOW incorporates physically based methods for simulating runoff and infiltration from snow and rain precipitation, as well as groundwater/surface-water interaction. It is intended to be used on watershed-scale problems that can range from a few square kilometers to several thousand square kilometers, and for time periods that range from months to several decades (Markstrom et al. 2008). In

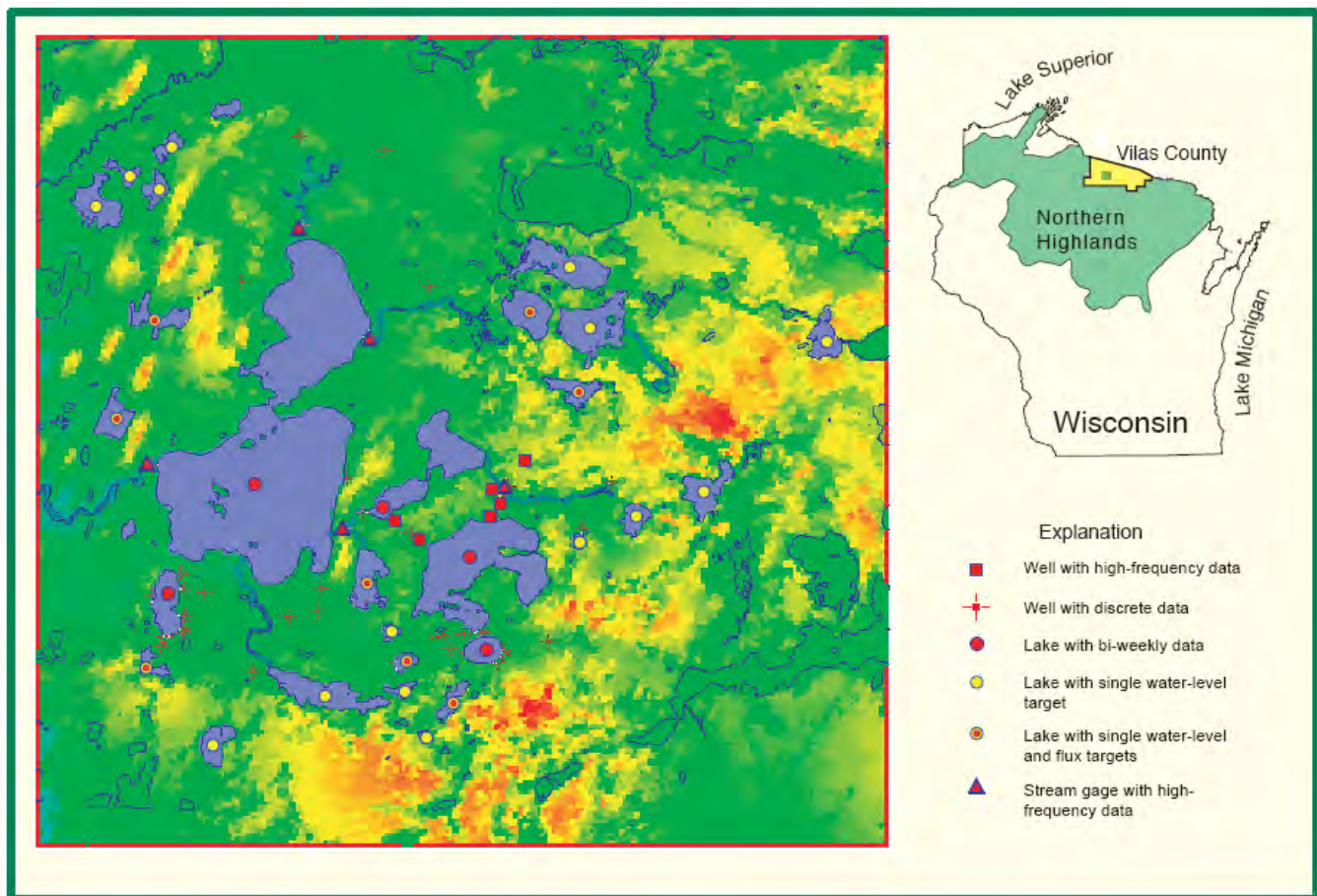

Figure 1. Top elevation, location, and extent of MODFLOW grid with location of calibration data. Warm colors represent higher elevation.

this work, GSFLOW was used to simulate the Trout Lake watershed in northern Wisconsin. The study area is one the densest lake districts in the world with extensive groundwater/surface-water interaction. The focus here is on elements of the model construction and calibration that are general to this type of modeling, and thus transferable to GSFLOW models constructed elsewhere. In addition, the model was run using several climate change scenarios. These are used to highlight the abilities of the coupled approach when applied to a question that has become of more import to decisionmakers.

Site Description and Model Construction

The Trout Lake basin is located in the Northern Highlands district in north central Wisconsin, in an area with many lakes (Figure 1). The aquifer consists of 40–60 m of unconsolidated Pleistocene glacial sediments mostly consisting of glacial outwash sands and gravel. The Trout Lake basin (which includes Trout Lake and all four of the basins that flow into the lake) has been

the focus of previous regional modeling studies including a two-dimensional analytic element screening model and three-dimensional, finite-difference models. See Walker and Bullen (2000) for additional descriptions of the setting and Pint (2002) and Hunt et al. (2005) for more description of previous modeling efforts.

Constructing the GSFLOW model

Many watershed models include only the watershed of interest defined by surface topography; although this assumption may be acceptable in montane settings, most watersheds are not in montane settings but may be in areas where the ground-watershed and surface-watershed do not align (e.g., Hunt et al. 1998). Therefore, the watershed of interest to be simulated in a coupled model is really both the surface-watershed and ground-watershed. The ground-watershed, however, is not well known in most cases; thus, a larger model is commonly used to define physically based perimeter boundaries for a smaller inset model (e.g., Hunt et al.

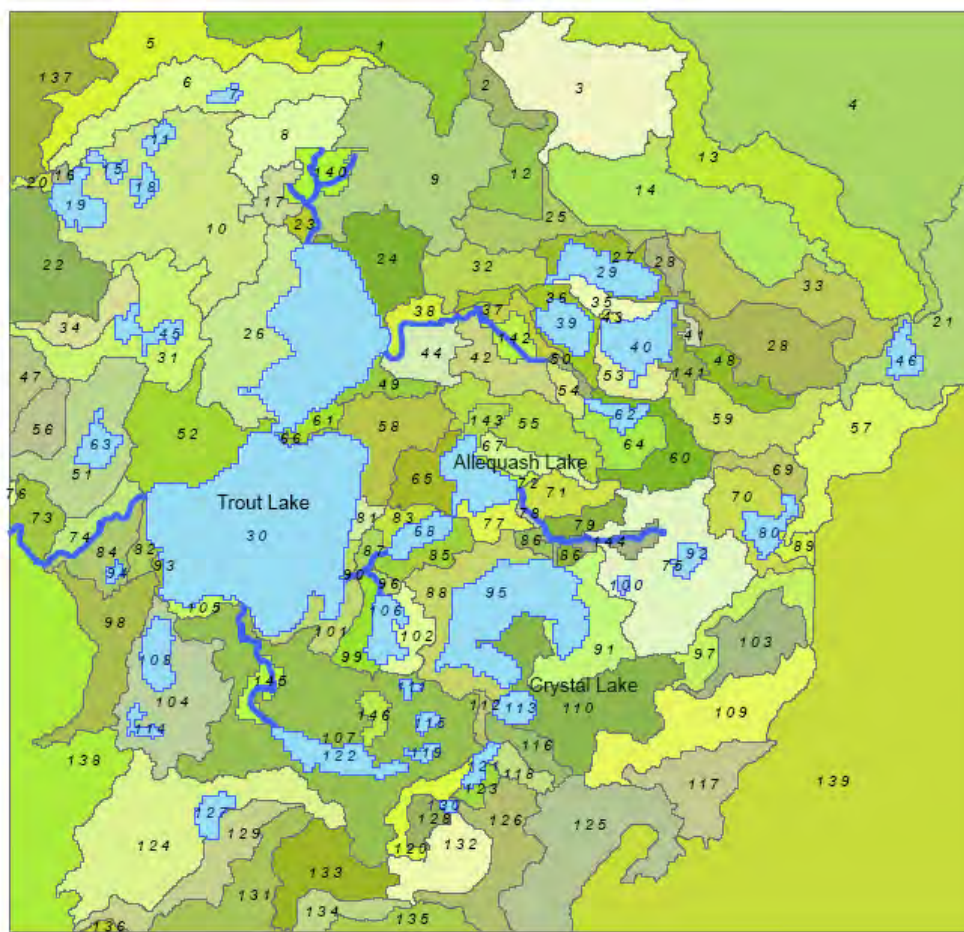

Figure 2. PRMS hydrologic response units located on the MODFLOW model domain.

1998); the edges of the inset model are usually sufficiently distant that the area of interest is shielded from artifacts from the coarse regional representation of the flow system. Inset approaches result in a domain for the coupled model that is a rectangular grid typical of a MODFLOW model rather than the irregular shape typical of a surface-water model. The rectangular grid includes the entire groundwater and surface watershed for the watershed of interest, as well as areas not included in either (Figures 1 and 2). This larger extent is not problematic as GSFLOW is designed to simulate one or more adjacent watersheds; however, this can confound simple representations of output as GSFLOW currently reports a total mass balance for the entire model domain. Thus, additional post-processing may be required to fully distribute the total model flows between the watershed of interest and the remainder of the simulated area.

Calibration strategy

In many ways the groundwater system can be thought of as a “low pass filter” that removes much of the short-term transient dynamics and leaves the resilient long-term system dynamics. New model construction considerations and potential problem areas arise when the surface-water system is coupled to the groundwater system. Issues with surface-water model calibration are well documented; one such issue is that only a handful of the many parameters that may be employed by a surface-water (or coupled) model are actually estimable on the basis of most calibration datasets (e.g., Beven and Freer 2001; Doherty and Hunt, in press). This suggests that, although more processes can be included in the code, our ability to constrain the parameters needed to employ the additional functionality may not be commensurate. Fully coupled models also require longer run times than either MODFLOW or PRMS models running alone, which can limit the exploration of the parameter solution space (Hill 2006). Thus, a “dual” calibration approach was employed in the Trout Lake modeling whereby the groundwater and surface-water models were calibrated separately using the “MODFLOW-only” and “PRMS-only” options in GSFLOW. The ground-water model was calibrated by polishing results from an earlier calibration (Muffels 2008). The surface-water model was calibrated using the step-wise procedure outlined by Hay et al. (2006). These independently calibrated models were then combined in a subsequent fully coupled GSFLOW run. The idea was to efficiently get both the groundwater and surface-water model

parameters “in the ballpark.” Ongoing work is focusing on approaches for calibrating fully coupled models with derivative methods, as well as assessing different nonderivative calibration strategies for fully coupled GSFLOW models.

Time-series processing

In addition to issues of parameter insensitivity and correlation of observation data for constraining a coupled model, there are also concerns with measurement noise and redundant information as surface-water data sets commonly include many more observations than groundwater data sets—especially with respect to the temporal density of the observations. Because of these issues, we employed a time-series processing approach to reduce the time-series observations into characteristic aspects of the system. The simulated GSFLOW output was then processed in the same way as the raw observations and compared in the parameter estimation process. The processing was performed using the Time-Series Processor (TSPROC; Doherty 2003). TSPROC was modified to read native GSFLOW output generated by both the MODFLOW (e.g., GAGE Package) and PRMS (STATVAR file) portions of the model. TSPROC was used to create the parameter estimation control file for PEST (Doherty 2007), where it automatically translated the observation information to the parameter estimation process and created the necessary files to extract the simulated equivalents from the model output.

Preliminary calibration results

The parameters from the PRMS-only and MODFLOW-only calibrations were used with the fully-coupled GSFLOW model and provided a reasonable fit for lake levels and streamflows. In some cases the general pattern of the system response was simulated well, but there was an offset between the modeled and observed data. To remove the effects of these biases, time-series results for climate change scenarios are presented as a relative difference between the simulated series for current conditions and the simulated series for a given climate change scenario. The coupled model was able to simulate important characteristics of the system not typically explicitly considered by groundwater (MODFLOW) models, such as snowpack depth, lake evaporation, and streamflow duration. The ability to explicitly simulate these important but indirect drivers of the groundwater system using physically based

algorithms is expected to be critical for realistic simulations of the hydrologic system to potential climate change.

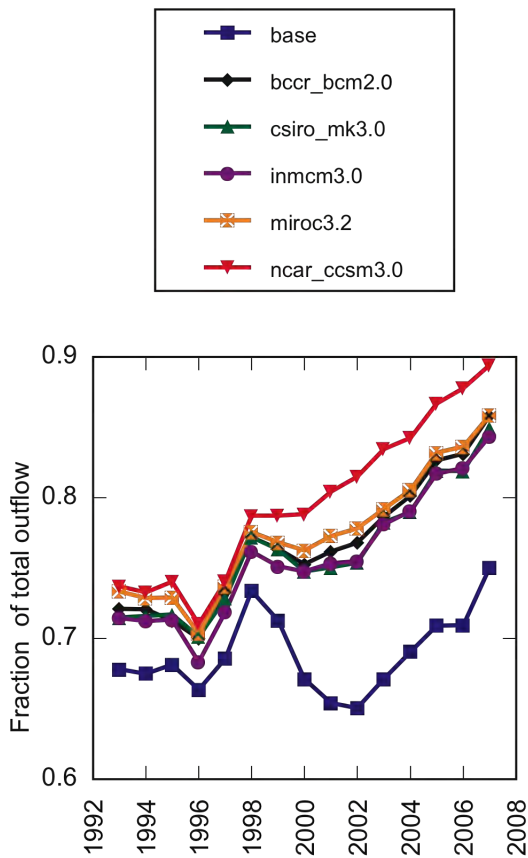

Figure 3. Comparison of annual evaporation from Crystal Lake across the 5 climate models. The base scenario is for the 1993–2007 period.

Climate Change Scenarios

Several climate models and one emission scenario were selected from the Intergovernmental Panel on Climate Change (Solomon et al. 2007) to illustrate the potential effects of climate change on the lake systems. The A2 emissions scenario (A2) was chosen, along with five climate models (bccr_bcm2.0–Bjerknes Centre for Climate Research, Norway; csiro_mk3.0–Commonwealth Scientific and Industrial Research Organization Atmospheric research, Australia; inmcm3.0–Institute for Numerical Mathematics, Russia; miroc3.2–Center for Climate System Research, Japan, medium resolution model; and ncar_ccsm3.0–National Center for Atmospheric Research, United States). There was a fair amount of variability in the results across the climate models; Figure 3 reports

results for annual evaporation from Crystal Lake from the various simulations.

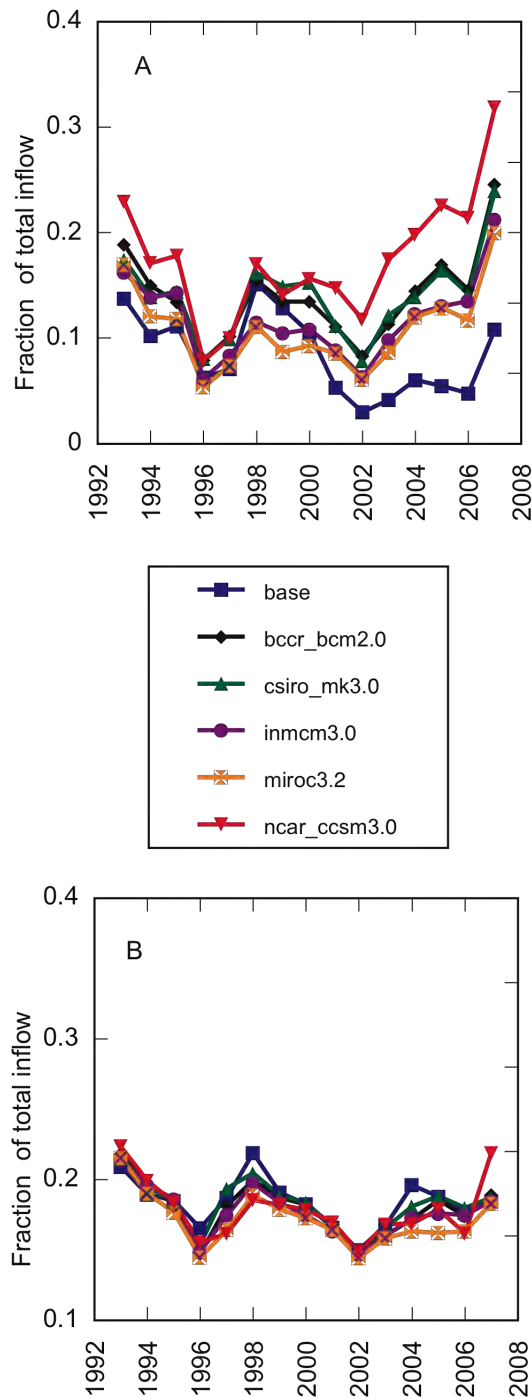

Figure 4. Simulated annual groundwater inflow to Crystal Lake (A) and Allequash Lake (B) for the five climate models. The base scenario is for the 1993–2007 period.

Values for the fraction of groundwater inflow to two lakes in the study area are depicted in Figure 4. Crystal Lake is a seepage lake located near the upper portion of the flow system, and Allequash Lake is a drainage Lake further down in the flow system. Note that the differences between current conditions and projected climate change conditions are more pronounced in the seepage lake than in the drainage lake. In fact, there appears to be little impact of climate change on groundwater inflow to the drainage lake, likely because its hydrologic budget is dominated by streamflow. An example of the potential changes to lake levels in Crystal Lake is depicted in Figure 5. The bulk of the models predict a substantial decrease in lake levels compared to current conditions (2–2.5 meter drop), and one model predicts decreases in excess of 3.5 meters. Note that even after 12 years of model simulation the predicted lake levels have not approached steady-state conditions.

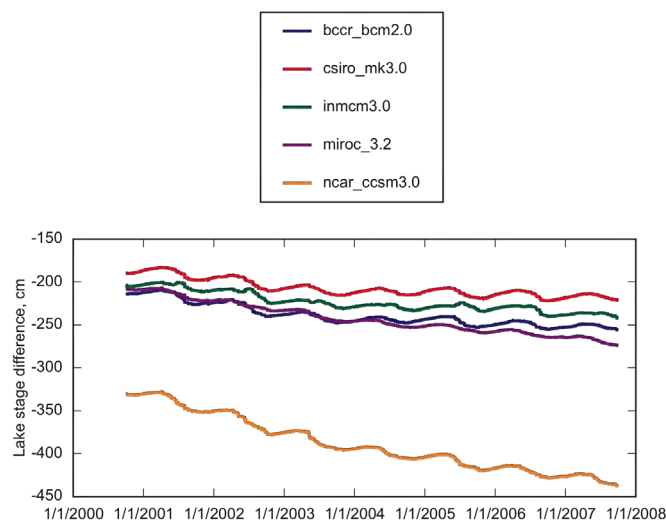

Figure 5. Simulated differences in lake stage between current conditions and simulated conditions from the five climate models.

Discussion and Conclusions

The results for potential lake-level changes as a result of climate change are dramatic and have obvious implications for the individual lakes. The results for groundwater inflow into the seepage lake are more subtle; however, for a soft-water lake such as Crystal, a potential threefold increase in groundwater inflow could have significant impact on the chemistry of the lake. In this paper, GSFLOW provided a simple and transparent way to simulate the effects of climate

change on the coupled hydrologic system. In addition, the ability to use physically based algorithms to extrapolate the system's processes as they move beyond the range of historic conditions is often lacking in other nondeterministic modeling approaches. Finally, its MODFLOW roots provides GSFLOW with a powerful foundation for simulating the groundwater portion of coupled systems, which is critical for realistic simulations of groundwater dependent ecosystems. The results presented here demonstrate the potential utility of GSFLOW modeling for today's resource management decisions.

Acknowledgments

This work was supported by the U.S. Geological Survey's Office of Ground Water and Trout Lake Water, Energy, and Biogeochemical Budgets (WEBB) program, in cooperation with the National Science Foundation's North Temperate Lakes Long-Term Ecological Research program (DEB-9632853). R. Steve Regan, Steve Westenbroek, Dave Prudic, Rich Niswonger, and Roland Viger are thanked for their extensive help during model construction and calibration. Tim Kratz and Mike Fienen are thanked for their thoughtful reviews of the manuscript.

References

- Beven, K.J., and J. Freer. 2001. Equifinality, data assimilation, and uncertainty estimation in mechanistic modelling of complex environmental systems. *Journal of Hydrology* 249:11–29.
- Doherty, J. 2003. TSPROC: A Time-Series Processor Utility. Watermark Numerical Computing, Brisbane, Australia.
- Doherty, J. 2007. Manual for PEST: Model Independent Parameter Estimation. Watermark Numerical Computing, Brisbane, Australia.
- Doherty, J., and R.J. Hunt. In press. Two easily calculated statistics for evaluating parameter identifiability and error reduction. *Journal of Hydrology*.
- Harbaugh, A.W. 2005. MODFLOW-2005, the U.S. Geological Survey modular ground-water model: The ground-water flow process: U.S. Geological Survey Techniques and Methods 6-A16, variously paginated.

- Hay, L.E., G.H. Leavesley, M.P. Clark, S.L. Markstrom, R.J. Viger, and M. Umemoto. 2006. Step wise, multiple objective calibration of a hydrologic model for a snowmelt dominated basin. *Journal of the American Water Resources Association* 42(4):877–890.
- Hill, M.C. 2006. The practical use of simplicity in developing ground water models. *Ground Water* 44(6): 775–781.
- Hunt, R.J., M.P. Anderson, and V.A. Kelson. 1998. Improving a complex finite-difference ground water flow model through the use of an analytic element screening model. *Ground Water* 36(6):1,011–1,017.
- Hunt, R.J., D.T. Feinstein, C.D. Pint, and M.P. Anderson. 2005. The importance of diverse data types to calibrate a watershed model of the Trout Lake Basin, northern Wisconsin. *Journal of Hydrology* 321(1–4):286–296.
- Hunt, R.J., and J.J. Steuer. 2000. Simulation of the recharge area for Frederick Springs, Dane County, Wisconsin. U.S. Geological Survey Water-Resources Investigations Report 00-4172, 33 p.
- Leavesley G.H., R.W. Lichty, B.M. Troutman, and L.G. Saindon. 1983. Precipitation-runoff modeling system: User's manual. U.S. Geological Survey Water-Resources Investigations Report 83-4238, 207 p.
- Leavesley G.H., S.L. Markstrom, R.J. Viger, and L.E. Hay. 2005. USGS Modular Modeling System (MMS): Precipitation-Runoff Modeling System (PRMS) MMS-PRMS. In V.P. Singh and D.K. Frevert, eds., *Watershed Models*, pp. 159–177. CRC Press, Boca Raton, FL.
- Markstrom S.L., R.G. Niswonger, R.S. Regan, D.E. Prudic, and P.M. Barlow. 2008. GSFLOW: Coupled ground-water and surface-water flow model based on the integration of the Precipitation-Runoff Modeling System (PRMS) and the Modular Ground-Water Flow Model (MODFLOW-2005). U.S. Geological Survey Techniques and Methods 6–D1. [online] URL: <http://pubs.usgs.gov/tm/tm6d1/>.
- Muffels, C. 2008. Application of the LSQR Algorithm to the Calibration of a Regional Groundwater Flow Model: Trout Lake Basin, Vilas County, WI.
- University of Wisconsin–Madison, Department of Geology and Geophysics. M.S. thesis. Madison, WI.
- Niswonger, R.G., D.E. Prudic, and R.S. Regan. 2006. Documentation of the Unsaturated-Zone Flow (UZFI) Package for modeling unsaturated flow between the land surface and the water table with MODFLOW-2005. U.S. Geological Survey Techniques and Methods 6-A19.
- Pint, C.D. 2002. A Groundwater Flow Model of the Trout Lake Basin, Wisconsin: Calibration and Lake Capture Zone Analysis. University of Wisconsin–Madison, Department of Geology and Geophysics. M.S. thesis. Madison, WI.
- Solomon, S., D. Qin, M. Manning, M. Marquis, K. Averyt, M.M.B. Tignor, H.L. Miller, Jr., and Z. Chen, eds. 2007. *Climate Change 2007: The Physical Science Basis. Contribution of Working Group I to the Fourth Assessment Report of the Intergovernmental Panel on Climate Change*. Cambridge University Press, New York.
- Steuer, J.J., and R.J. Hunt. 2001. Use of a watershed-modeling approach to assess hydrologic effects of urbanization, North Fork Pheasant Branch Basin near Middleton, Wisconsin. U.S. Geological Survey Water-Resources Investigations Report 01-4113, 49 p.
- Walker, J.F., and T.D. Bullen, 2000. Trout Lake, Wisconsin: A water, energy, and biogeochemical budgets program site. U.S. Geological Survey Fact Sheet 161-99, 4 p.

Using Passive Capillary Samplers to Collect Soil-Meltwater Endmembers for Stable Isotope Analysis

Marty D. Frisbee, Fred M. Phillips, Andrew R. Campbell, Jan M.H. Hendrickx

Abstract

Snowmelt is the primary source of streamflow generation and recharge in much of the southwestern United States, so the stable isotopic composition of snowmelt recharge is a critical endmember in the hydrograph separation of streamflow generation. However, the methodologies available to collect meltwater for stable isotope analysis are limited due to the remote and often seasonally inaccessible nature of the terrain where snowpacks develop. To address this problem, a robust methodology using passive capillary samplers (PCAPS) was developed. Lab results indicated that (1) the wicking process associated with PCAPS does not fractionate water, but precautions are necessary to prevent exchange between the wick and atmosphere, and (2) PCAPS effectively tracked the changing isotopic composition of a soil reservoir undergoing evaporation. To test this methodology in the field, twelve PCAPS were installed at remote sites within the Saguache Creek watershed, a large subwatershed of the Rio Grande in the San Juan Mountains of southern Colorado, during October 2007 prior to the onset of snow accumulation. Bulk and modified-bulk snow collectors were installed at each PCAPS installation site to quantify the isotopic evolution of the snow and snowmelt. Field results indicate that the stable isotopic composition of infiltrating meltwater collected via PCAPS had evolved relative to the isotopic compositions obtained via modified-bulk snow collectors. This outcome may be

the result of mixing of evaporated soil-water present before snow accumulation with intermittent and (or) late season pulses of isotopically depleted snowmelt water within the soil matrix. The information on the stable isotopic evolution of infiltrating meltwaters cannot be obtained from bulk and modified-bulk snow collectors. For example, this PCAPS design can be deployed at multiple depths within the same soil profile, thus providing greater insight into the processes controlling the isotopic evolution of deep percolation. Therefore, the PCAPS methodology is particularly useful in collecting soil-meltwater endmembers in remote, seasonally inaccessible watersheds and can provide much needed information on the processes that affect subsurface runoff and the consequent geochemical evolution of the infiltrating waters. This design may also be useful in remote, snowbound areas such as the Sierra Nevada where base cation loss and acidification are concerns during the snowmelt season.

Keywords: snowmelt, soil-water, PCAPS, wick sampler, stable isotope

Introduction

Many of the river basins in the southwestern United States depend upon snowmelt for streamflow generation (Winograd et al. 1998, Rango 2006), so an understanding of the processes which control streamflow generation in the headwaters of these basins is critical for the sustainability of future agricultural, domestic, and municipal water demands. Research into these processes has historically employed a variety of techniques including isotopic hydrograph separation. However, quantification of the snowmelt-infiltration endmember is problematic due to the rugged, remote, and seasonally inaccessible nature of these mountainous watersheds. These conditions often preclude frequent sampling intervals and as a

Frisbee is a Ph.D. Candidate in Hydrology at New Mexico Tech, Socorro, NM, 87801. Phillips and Hendrickx are Professors of Hydrology and Campbell is a Professor of Geology at the Department of Earth and Environmental Science, New Mexico Tech, Socorro, NM 87801. Emails: mfrisbee@nmt.edu; phillips@nmt.edu; campbell@nmt.edu; hendrick@nmt.edu.

consequence, eliminate certain vadose-zone sampling techniques. Nonetheless, it is critical that the snowmelt-infiltration endmember be correctly identified. The isotopic composition of snowpacks can be altered by vapor exchange processes occurring between the snowpack and atmosphere and by exchange between meltwater infiltrating through the snowpack and the remnant snowpack (Clark and Fritz 1997). Previous work has shown that for these reasons the isotopic composition of fresh snow and (or) remnant snowpack can differ greatly from the isotopic composition of the snowmelt runoff (Herrmann et al. 1981, Hooper and Shoemaker 1986, Taylor et al. 2001). Therefore, assuming that the isotopic composition of fresh snow and (or) surface runoff from snowmelt is the same as that of the end-season snowpack can result in errors in the hydrograph separation and (or) in estimation of recharge contributions—most commonly the overestimation of pre-event water sources and underestimation of event water (Feng et al. 2002, Taylor et al. 2002, Liu et al. 2004, Earman et al. 2006). In order to increase the accuracy of isotopic separations, Earman et al. (2006) suggested that the isotopic composition of water collected via modified-bulk collectors may be more representative of actual snowmelt recharge. They used the isotopic compositions of fresh snow and that from the modified-bulk collector to calculate the contribution of snowmelt to recharge. The fresh snow endmember resulted in a contribution of 32 percent while the modified-bulk collector endmember resulted in 53 percent. This outcome illustrates the discrepancy between these two endmembers. Therefore, a robust method requiring little maintenance or monitoring is needed to sample the isotopic signature(s) of snowmelt infiltration in these watersheds and further refine our predictions of the contribution of snowmelt to recharge and streamflow generation.

Passive capillary samplers (PCAPS) may be useful in collecting snowmelt infiltration in these remote, seasonally snowbound watersheds. The PCAPS concept was developed by Brown et al. (1986) and was subsequently evaluated by Holder et al. (1991) and Knutson and Selker (1994). The samplers are constructed from fiberglass wicks, with the length and diameter chosen to match the matric potential of the soil to be sampled. The wicks behave essentially like hanging water columns, thus allowing water to be drawn from the surrounding soil with little or no maintenance, no application of external suction, and, unlike the zero-tension lysimeter, no dependency upon

positive pressure (Boll et al. 1992). They have since been used quite extensively in vadose-zone studies.

Passive capillary samplers have also been deployed to collect soil water for stable isotope analysis in agricultural settings (Landon et al. 1999, Landon et al. 2000, Delin and Landon 2002). These studies used a standard PCAPS design described in the work of Brown et al. (1986) that may not be feasible in mountainous, subalpine settings where soils are often thin and rocky. Therefore, a modification of the standard design was necessary to accommodate the soils encountered in mountainous watersheds, and a simple laboratory experiment was conducted to ascertain the suitability of using PCAPS in these studies (Frisbee et al., in press). The experimental results indicated that the wicking process associated with PCAPS does not fractionate water but that certain precautions are necessary to prevent exchange between the wick and atmosphere. Also, the modified PCAPS design effectively tracked the changing isotopic composition of a soil reservoir undergoing evaporation (Frisbee et al., in press). In order to thoroughly field test this design modification, twelve PCAPS were installed in remote locations of the Saguache Creek watershed in the San Juan Mountains of southern Colorado prior to the onset of snow accumulation in October 2007. This field evaluation was designed to answer important questions regarding the deployment of modified PCAPS to collect snowmelt for stable isotopic analyses: (1) Is the isotopic composition of water collected via modified-bulk snow collectors similar to that of the actual infiltrating snowmelt? (2) Does the modified PCAPS design preserve the stable isotopic composition of actual infiltrating meltwater or is it affected by kinetic processes?

Methods

A 50-ft coil of fiberglass wick having a diameter of 9.5 mm (3/8 inch, Pepperell Braiding Company SKU # 1380) was used in this study. The wicks were thoroughly pretreated by soaking and rinsing the wicks in deionized water several times daily for a duration of 3 weeks to ensure that manufacturing residues were removed. The degree of cleanliness was ascertained by measuring the electrical conductivity of the rinse water after each soak. Samples of the final rinse water were also subjected to standard chemical analyses to provide chemical benchmarks for the field application. The wicks were cut 60.9 cm (2 ft) long resulting in a wick

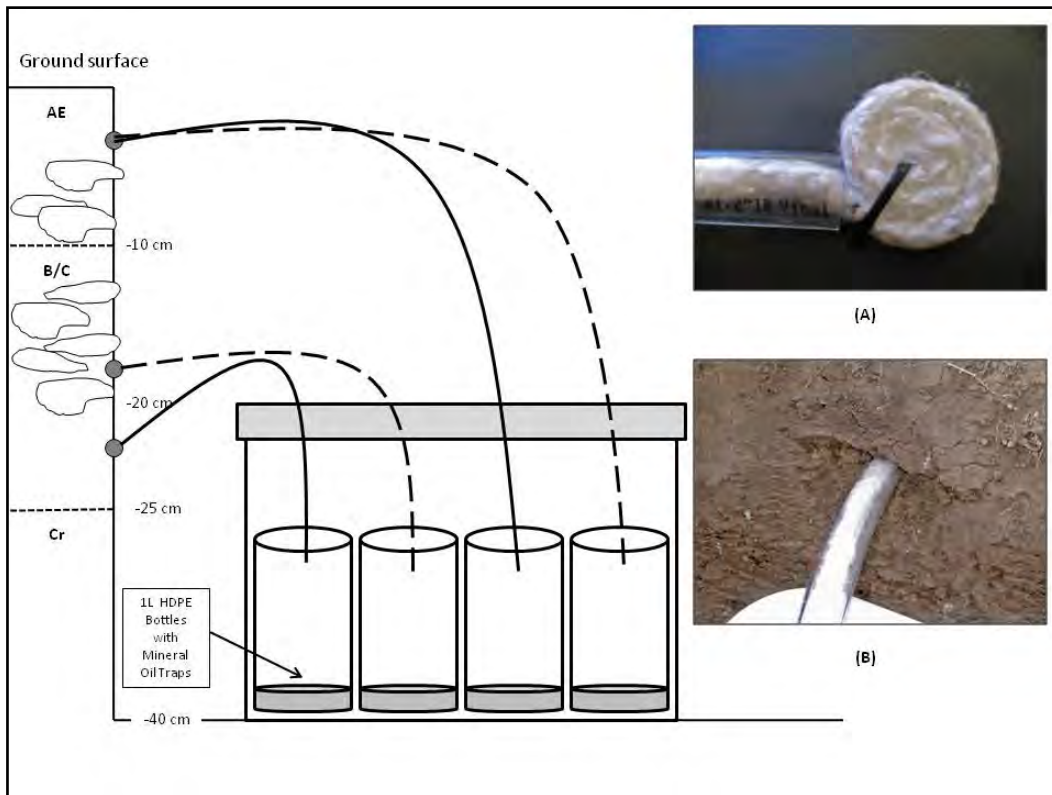

Figure 1. Diagram of typical PCAPS installation. Two PCAPS were installed at shallow depths and two were installed deeper in the soil profile. Dashed and solid lines represent paired PCAPS. Inset A is a close-up photo of “fiddlehead” and tubing assembly. Inset B is a close-up photo of an actual installation in a soil profile.

matric potential (ψ_{wick}) of -60.9 cm at soil fluxes equal to 0 (Knutson and Selker 1994). One end of each wick was coiled into a “fiddlehead” shape and then securely yet loosely fastened in place using zip-ties (Figure 1, Inset A). Typically a straight length of 7 inches (17.8 cm) could be coiled tightly to produce a collection surface of approximately 3 to 4 cm in diameter. Soil pits were dug in three remote locations in the watershed. All pits were installed to a depth of approximately 40 cm. A weathered bedrock layer (Cr) was encountered at 15 to 25 cm below the surface. Most soils have little organic development, thin AE horizons, and are broadly classified as stony to cobbly or gravelly loams. The locations of these pits were based on the aspect of the slopes, elevation, and typical snowpack accumulation (Figure 2). For example, all sites were located in high elevation meadows, which should have been conducive to snowpack accumulation and persistence. The elevations of these sites ranged from 9,370 ft (2,857 m) to 10,250 ft (3,124 m). Four lateral, horizontal holes were then dug into the walls of each soil pit using gardening spades and pocket knives to a lateral depth of approximately 5 to 7 inches (12.7

to 17.8 cm). The wick assembly was pulled through flexible PVC tubing with an outer diameter of 1.59 cm (5/8 inch) and an inner diameter of 1.27 cm (1/2 inch). The “fiddlehead” was then inserted into the hole and the hole was backfilled with native soil in an attempt to maintain soil hydraulic properties. Thus, the “fiddlehead” was placed in direct contact with the soil while the remainder of the wick was entirely enclosed within flexible PVC tubing (Figure 1, Inset B). Passive capillary samplers typically comprise a water collection plate that has wick fibers glued to the top of it and a wick draining from the center of the plate down to a collection bottle, resulting in overall assembly lengths up to 100 cm (Brown et al. 1986). Our design modification was necessary because the shallow, rocky soils common in this mountainous watershed cannot accommodate the assembly length associated with the standard PCAPS design. Each soil pit contained two shallow PCAPS located at depths less than 10 cm and two deep PCAPS located at depths of approximately 20 cm (Figure 1).

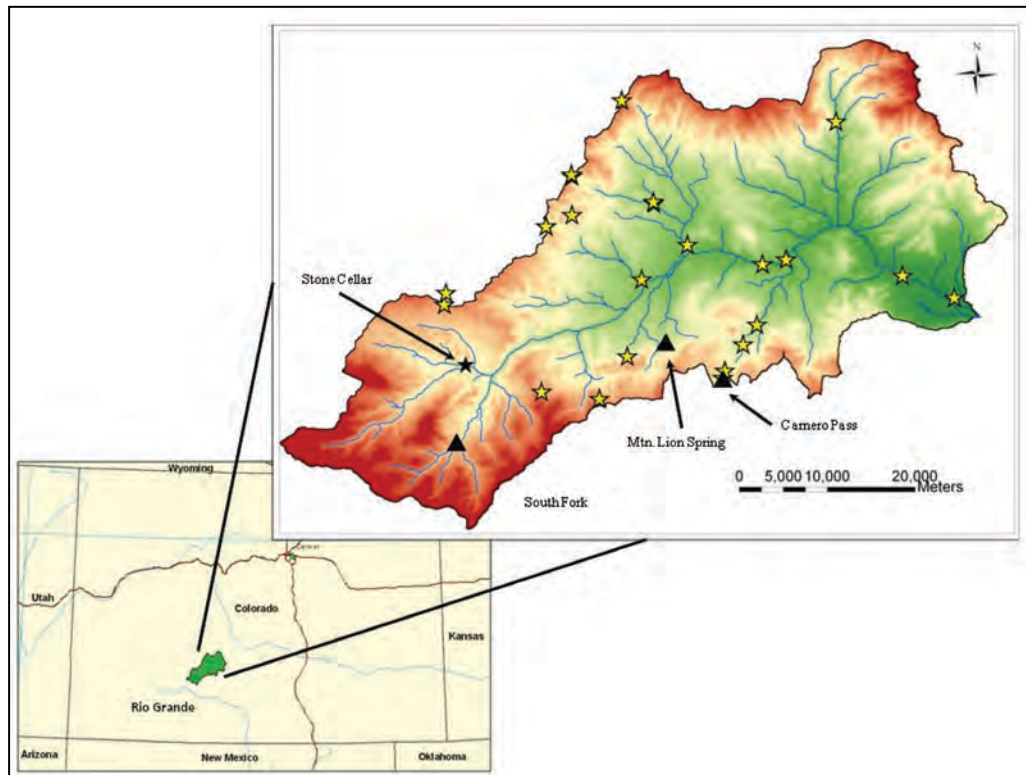

Figure 2. Map of Saguache Creek watershed. Yellow stars indicate locations of snow and (or) snowmelt runoff sampling sites, black triangles indicate locations of PCAPS installations and snow collectors, and the black star indicates the location of a stand-alone snow collector site.

A plastic collection box was then assembled which contained four 1-L LDPE bottles. Each bottle contained a small reservoir of mineral oil to prevent evaporation and atmospheric exchange. The mouth of each bottle was covered with a Ziploc[®] sandwich bag that was securely wrapped around the bottle using zip-ties. Each tubing/wick assembly was pushed through an access hole in the lid of the plastic collection box and the open end of the wick assembly was pushed through the Ziploc[®] and into the mouth of the bottle (Figure 1). Silicon sealant was applied at the juncture of the tubing and the box to prevent leaking and flow along the outside of the tubing. Each pit was then covered with a heavy duty plastic drop cloth and wooden covers were placed over the drop cloth to prevent overburden failure.

The PCAPS were installed prior to the onset of snowpack accumulation during October 2007. Each soil pit location was accompanied by the installation of a bulk and modified-bulk snow collector. Bulk collectors preserve the integrated isotopic composition of fresh snow. Modified-bulk collectors delay the

snow from falling into the mineral oil trap and consequently, allow atmospheric exchange processes to occur. This collector is thought to preserve an integrated composition similar to actual recharge. The bulk collector was constructed from a 6-ft (1.83-m) length of 4-inch (10.2-cm) PVC pipe. A flat cap was cemented to the bottom of the pipe and a small reservoir of mineral oil was poured into the pipe. The modified-bulk snow collector was constructed from two 3-ft (0.92-m) lengths of 4-inch (10.2-cm) PVC pipe. Two 4-inch circular sections of fine mesh, 10 grids per inch, were cut and placed inside a PVC coupling fitting. The two lengths of PVC were then affixed to the coupling fitting, a flat termination cap was cemented to the lower PVC, and a mineral oil reservoir was poured inside the pipe assembly. These large-scale modifications to the designs used in the work of Earman et al. (2006) were necessary due to the possibility of snowpacks exceeding 4–5 ft (1.22–1.52 m) in the backcountry. The snow collectors were also installed prior to the onset of snowpack accumulation during October 2007.

All water samples captured by the snow collectors and the water samples obtained from the PCAPS were removed during the first week of June 2008. Each water sample was analyzed for $\delta^{18}\text{O}$ and δD . The $\delta^{18}\text{O}$ composition was measured on 1 mL samples of water using the $\text{CO}_2/\text{H}_2\text{O}$ equilibration method described in Clark and Fritz (1997) using a Thermo Finnigan Gasbench operated in continuous flow mode. The δD composition was measured by metal reduction with powdered chromium at 850°C in an H-Device (Nelson and Dettman 2001) and analyzed in dual inlet mode. Both CO_2 and H_2 were analyzed on a Thermo Finnigan Delta^{PLUS} XP Stable Isotope Ratio Mass Spectrometer. At the time of sample retrieval, two soil samples, one shallow and one deep, were removed from the Carnero Pass installation. Water was vacuum distilled from the soil samples using the vacuum distillation method described in the work of Araguás-Araguás et al. (1995) and later analyzed for $\delta^{18}\text{O}$ and δD . The variability in $\delta^{18}\text{O}$ and δD was ascertained by analyzing 21 duplicates. Variability in $\delta^{18}\text{O}$ ranged from 0.0 to 0.5 ‰ (only one duplicate varied by 0.5 ‰). The duplicates of δD varied from 0 to 2 ‰ (only one duplicate varied by 2 ‰).

Results

Samples of early season and late season (fresh) snow, late season remnant snowpack, and late season surface runoff were collected during the winters and snowmelt seasons of 2006, 2007, and 2008. These samples were fit with a linear trendline resulting in the equation $\delta\text{D} = 7.7\delta^{18}\text{O} + 5$ ($R^2 = 0.97$). In Figure 3, that snow evolution line (SEL) is compared with the local meteoric water line (LMWL) for all precipitation samples in the watershed and the global meteoric water line (Craig 1961). The LMWL is given by the equation $\delta\text{D} = 8.3\delta^{18}\text{O} + 19$ ($R^2 = 0.99$). As can be seen in Figure 3, evaporation (sublimation) does not appear to be the primary process controlling isotopic fractionation as the slope of the SEL is close to 8. Shallow and deep PCAPS samples from the South Fork and Carnero Pass installations are also plotted in Figure 3. As expected, the PCAPS samples plot within the area separating early season snow from late season snowpack and surface runoff. The PCAPS samples do not exhibit any significant kinetic alteration due to evaporation or sublimation since they plot along the SEL.

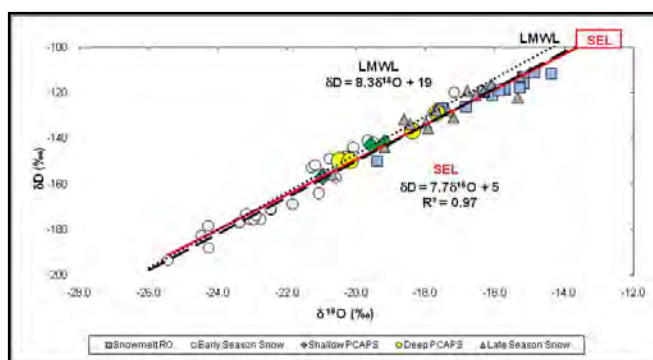

Figure 3. The solid red trendline represents the evolution of early season snow, late season snow, and surface runoff from snowmelt—the snow evolution line (SEL). The dashed line is the global meteoric water line given by Craig (1961). The dotted line is the local meteoric water line fit to all precipitation samples (rainfall and snow) in the Saguache Creek watershed.

Three of the four PCAPS pairs show some degree of isotopic mixing with depth (Figure 4). The isotopic composition of the fourth pair, South Fork–A, is the same, within error. Interestingly, the individual trendlines shown in Figure 4 as arrows effectively bracket the SEL shown in Figure 3. These results are, at first, encouraging since kinetic fractionation within the soil pit between the wick and the atmosphere was an initial concern. However, the wicks are essentially in a closed system as long as there are no leakage points along the length of the tubing that houses the wick between the soil pit wall and the collection bottle (Frisbee et al., in press). It should be noted that a short length of tubing should also be installed inside the lateral holes of the soil pit wall to limit the possibility of wick exposure outside the soil pit wall (see Figure 1, Inset B). It is also encouraging to note that the shallow PCAPS do appear to preserve the isotopic composition of the bulk and modified-bulk snow collectors. However, since little if any isotopic evolution occurred between the bulk and modified-bulk snow collectors, it would seem that answering question 1 would be problematic. We think, on the other hand, that these results clearly illustrate that the isotopic composition of infiltrating meltwater may be significantly different than that which is measured on the soil surface. This evolution takes place within a relatively shallow soil profile and the consequences of this evolution may have serious implications for endmember mixing analyses aimed at quantifying the contributions of snowmelt recharge to streamflow generation in these landscapes.

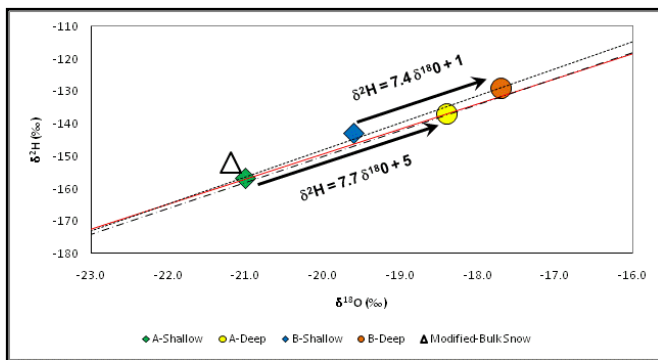

Figure 4. Evolution of PCAPS water samples in Carnero Pass. Open triangle is Modified-Bulk Snow, diamonds represent shallow PCAPS samples and circles represent deep PCAPS samples. Isotopic evolution in each pair is indicated by arrows. The red line is the SEL, the dotted line is the LMWL, and the dash-dot line is the GMWL given by Craig (1961).

It is readily apparent from Figure 4 that the shallow PCAPS samples appear to preserve the isotopic composition of the bulk and modified-bulk snow samples while the isotopic composition of infiltrating meltwater can be significantly different at a relatively shallow depth of 20 cm as compared to the meltwater collected in the shallow subsurface. To further examine this phenomenon, we can focus on the Carnero Pass samples and plot the snow, PCAPS, and soil water samples from that site only (Figure 5). The infiltrating water samples do not appear to be heavily evaporated since the slopes of the trendlines are very near 8. If, for example, evaporation had occurred in the soil or during the wicking process, a slope of between 3 to 5 in the trendlines of the PCAPS samples would be apparent. The soil in the Carnero Pass soil pit was still moist when the samples were retrieved yet the soil samples were taken from the pit face that had likely undergone evaporation. Thus, the two soil samples plot away from the SEL (Figure 5). The shallow soil sample plots on a trendline with a slope of 6.3 relative to the preserved isotopic composition of the shallow PCAPS while the deep soil sample plots on a trendline with a slope of 2.8. All other soil pits were dry at the time of retrieval. It is more plausible that the PCAPS trendlines are the result of mixing in the soil profile whereby persistent diffuse melting from the snowpack and (or) intermittent periods of melt occurring over the course of winter create periods of sporadic infiltration into the soil. Therefore, mixing can occur between newly infiltrating meltwater and soil water that reflects previous infiltration, and which may create conditions

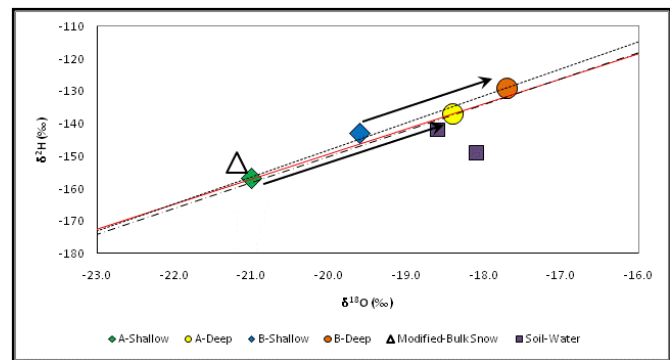

Figure 5. Evolution of Carnero Pass samples. Soil-water samples (purple squares) were obtained only at the Carnero Pass site.

where subsequent meltwater infiltration can mix with soil water that has already undergone isotopic alteration with depth (Merlivat 1978).

Conclusions

We initially designed this field evaluation to test the suitability of a modified passive capillary sampler design for collecting the integrated isotopic composition of snowmelt-infiltration. We were interested in testing the assumption that the isotopic composition of water collected by modified-bulk snow collectors is similar to that of actual infiltration during snowmelt. While the modified-bulk collectors employed during the 2007–2008 winter season did not experience significant isotopic alteration, it is apparent that the assumption may not be valid in all cases. Isotopic evolution of infiltrating meltwater did occur in these shallow, rocky subalpine soils to such an extent that the deep PCAPS samples were not similar to the isotopic composition of the waters retrieved from the snow collectors. In addition, if properly installed in the soil, the wicking process associated with the PCAPS design does not fractionate water. Thus, the isotopic compositions of the infiltrating meltwaters are preserved. Overall, the performance of the modified PCAPS design was encouraging, and we conclude that this design may be particularly useful in collecting snowmelt infiltration endmembers in remote, seasonally inaccessible watersheds. This design can provide much needed information on the processes that affect subsurface runoff and the consequent isotopic evolution of the infiltrating waters. This design may also be useful in remote, snowbound areas such as the Sierra Nevada where base cation loss and acidification are concerns during the snowmelt season.

Acknowledgments

Funding for this research was provided by the SAHRA (Sustainability of semi-Arid Hydrology and Riparian Areas) Science and Technology Center of the National Science Foundation (NSF agreement EAR-9876800). We thank Steve Sanchez of the Bureau of Land Management Saguache Field Office for logistical support in securing sites for field installations in the Saguache Creek watershed. We thank Emily Engle, Andrew Fargo, Jesus Gomez, Andre Ritchie, and Sam Siemens for field assistance. Our manuscript was greatly improved by the reviews provided by Paul D. Brooks (University of Arizona), Glendon Gee (Pacific Northwest National Laboratory) and Brent D. Newman (International Atomic Energy Agency).

References

- Araguás-Araguás, L., K. Rozanski, R. Gonfiantini, and D. Louvat. 1995. Isotope effects accompanying vacuum extraction of soil water for stable isotope analyses. *Journal of Hydrology* 168:159–171.
- Boll, J., T.S. Steenhuis, and J.S. Selker. 1992. Fiberglass wicks for sampling of water and solutes in the vadose zone. *Soil Science Society of America Journal* 56:701–707.
- Brown, K.W., J.C. Thomas, and M.W. Holder. 1986. Development of a capillary wick unsaturated zone water sampler. U.S. Environmental Protection Agency, Environmental Monitoring Systems Laboratory, Las Vegas, NV, Cooperative Agreement CR812316-01-0.
- Clark, I., and P. Fritz. 1997. *Environmental Isotopes in Hydrogeology*. Lewis, Boca Raton, FL.
- Craig, H. 1961. Isotopic variations in meteoric waters. *Science* 133:1,702–1,703.
- Delin, G.N., and M.K. Landon. 2002. Effects of surface run-off on the transport of agricultural chemicals to ground water in a sandplain setting. *The Science of the Total Environment* 295:143–155.
- Earman, S., A.R. Campbell, F.M. Phillips, and B.D. Newman. 2006. Isotopic exchange between snow and atmospheric water vapor: Estimation of the snowmelt component of groundwater recharge in the southwestern United States. *Journal of Geophysical Research* 111:D09302.
- Feng, X., S. Taylor, and C.E. Renshaw. 2002. Isotopic evolution of snowmelt: 1. A physically based one-dimensional model. *Water Resources Research* 38(10):1,217.
- Frisbee, M.D., F.M. Phillips, A.R. Campbell, and J.M.H. Hendrickx. In press. Modified passive capillary samplers for collecting samples of snowmelt infiltration for stable isotope analysis in remote, seasonally inaccessible watersheds: 1. Laboratory Evaluation. *Hydrological Processes*.
- Herrmann, A., M. Lehrer, and W. Stichler. 1981. Isotope input into runoff systems from melting snow covers. *Nordic Hydrology* 12:309–318.
- Holder, M., K.W. Brown, J.C. Thomas, D. Zabcik, and H.E. Murray. 1991. Capillary-wick unsaturated zone soil pore water sampler. *Soil Science Society of America Journal* 55(5):1,195–1,202.
- Hooper, R.P., and C.A. Shoemaker. 1986. A comparison of chemical and isotopic hydrograph separation. *Water Resources Research* 22:1,444–1,454.
- Knutson, J.H., and J.S. Selker. 1994. Unsaturated hydraulic conductivities of fiberglass wicks and designing capillary wick pore-water samplers. *Soil Science Society of America Journal* 58:721–729.
- Landon, M.K., G.N. Delin, S.C. Komor, and C.P. Regan. 1999. Comparison of the stable-isotopic composition of soil water collected from suction lysimeters, wick samplers, and cores in a sandy unsaturated zone. *Journal of Hydrology* 224:45–54.
- Landon, M.K., G.N. Delin, S.C. Komor, and C.P. Regan. 2000. Relation of pathways and transit times of recharge water to nitrate concentrations using stable isotopes. *Ground Water* 38(3):381–395.
- Liu, F., M.W. Williams, and N. Caine. 2004. Source waters and flow paths in an alpine catchment, Colorado Front Range, United States. *Water Resources Research* 40:W09401.
- Merlivat, L. 1978. Molecular diffusivities of H₂¹⁶O, HD¹⁶O, and H₂¹⁸O in gases. *Journal of Chemical Physics* 69:2,864–2,871.

Nelson, S.T., and D. Dettman. 2001. Improving hydrogen isotope ratio measurements for on-line chromium reduction systems. *Rapid Communications in Mass Spectrometry* 15:2,301–2,306.

Rango, A. 2006. Snow: The real water supply for the Rio Grande Basin. *New Mexico Journal of Science* 44:99–118.

Taylor, S., X. Feng, J.W. Kirchner, R. Osterhuber, B. Klauke, and C.E. Renshaw. 2001. Isotopic evolution of a seasonal snowpack and its melt. *Water Resources Research* 37(3):759–769.

Taylor, S., X. Feng, M. Williams, and J. McNamara. 2002. How isotopic fractionation of snowmelt affects hydrograph separation. *Hydrological Processes* 16:3,683–3,690.

Winograd, I.J., A.C. Riggs, and T.B. Coplen. 1998. The relative contributions of summer and cool-season precipitation to groundwater recharge, Spring Mountains, Nevada, USA. *Hydrogeology Journal* 6:77–93.

Using High-Frequency Sampling to Detect Effects of Atmospheric Pollutants on Stream Chemistry

Stephen D. Sebestyen, James B. Shanley, Elizabeth W. Boyer

Abstract

We combined information from long-term (weekly over many years) and short-term (high-frequency during rainfall and snowmelt events) stream water sampling efforts to understand how atmospheric deposition affects stream chemistry. Water samples were collected at the Sleepers River Research Watershed, VT, a temperate upland forest site that receives elevated atmospheric deposition of pollutants such as nitrogen (N) and mercury (Hg). Our use of high-frequency sampling documents responses of nutrients and mercury in streamflow to atmospheric deposition inputs to the watershed.

Keywords: atmospheric deposition, dissolved organic matter, mercury, nitrogen, Sleepers River Research Watershed, stream chemistry

Introduction

Routine surface water sampling schemes provide baseline information to elucidate the effects of ecological disturbance. In the northeastern United States, one disturbance that affects forests is chronic atmospheric deposition of pollutants. Emissions from sources including power plants, vehicles, agriculture, and industry can be transported and dispersed over large areas to blanket even the most pristine forests (Driscoll et al. 2003, Driscoll et al. 2007). Many long-term watershed studies assess trends and the effects of ecological disturbances by measuring stream water

chemistry at fixed intervals (weekly, monthly, or quarterly). Here we demonstrate that additional high-frequency sampling may yield important information that is needed to discern both short- and long-term effects of atmospheric deposition on biogeochemical transformations and solute transport in watersheds.

Surface water chemistry varies over time and space in response to complex biogeochemical and hydrological processes. In temperate forest environments, hydrological flushing of solutes along subsurface and surface flow paths during storm events links source areas of the landscape to stream chemistry (Creed et al. 1996, Boyer et al. 2000, Burns 2005). As such, atmospherically-deposited pollutants that accumulate in surficial soils may be exported from watersheds during stormflow (Sebestyen et al. 2008). This hydrological flushing of solutes is an example that highlights a need to better understand when, where, and how atmospherically-deposited pollutants cascade through biogeochemical cycles to affect solute availability and transport.

We give examples from the Sleepers River Research Watershed that highlight the importance of linking routine weekly sampling with intensive, high-frequency sampling to discern sources, transformations, and transport processes that affect the variation of stream solutes (nitrate, mercury, and dissolved organic matter) that are affected by atmospheric deposition.

Methods

Stream water samples were collected from 2002 to 2005 at watershed 9 (W-9) of the Sleepers River Research Watershed, one of five sites in the U.S. Geological Survey (USGS) Water, Energy, and Biogeochemical Budgets program (Figure 1). The 40.5-ha, steep watershed has a mixed northern forest cover and is typical of upland forests in mountains of the

Sebestyen is a research hydrologist, U.S. Department of Agriculture Forest Service, Grand Rapids, MN 55744. Shanley is a research hydrologist, U.S. Geological Survey, Montpelier, VT 05601. Boyer is an associate professor of Water Resources, Pennsylvania State University, University Park, PA 16802. Email: ssebestyen@fs.fed.us.

northeastern United States. The soils are derived from glacial tills that overlie metamorphic bedrock. The climate is temperate with warm humid summers and cold winters during which snow accumulates in a seasonal snowpack.

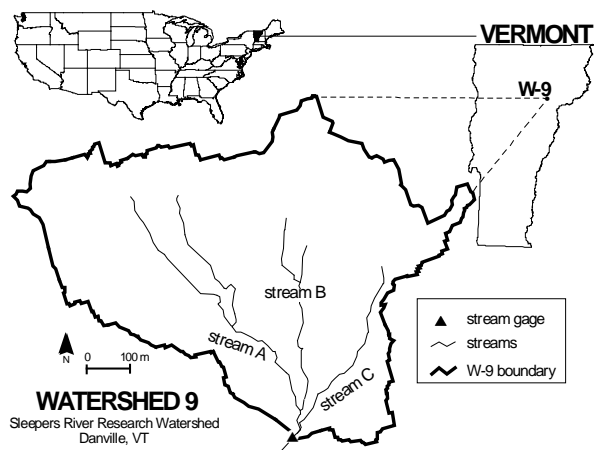

Figure 1. The location of W-9 at the Sleepers River Research Watershed in northeastern Vermont, United States.

Stream stage was measured every five minutes at a 90° V-notch weir and streamflow was calculated from a stage-discharge relationship. Samples of W-9 stream water were collected weekly and more frequently during stormflow, often using an ISCO automatic sampler to collect samples at intervals ranging from minutes to hours to days depending upon the timing and magnitude of streamflow changes. We also measured isotopic and chemical tracers in precipitation, groundwater, and soil water on an event basis. Samples were collected, processed, and analyzed according to standard methods that are detailed elsewhere for nitrate and dissolved organic carbon (DOC) concentrations (Sebestyen et al. 2008) and total and methylmercury (Hg) concentrations (Shanley et al. 2008). We apportioned nitrate sources for a subset of the samples using hydrochemistry, isotopic tracers, and end-member mixing analysis as detailed in Sebestyen et al. (2008).

Results and Discussions

High-frequency sampling generates large numbers of samples and is both labor and resource intensive but yields insights on the effects of atmospheric deposition on ecosystem functions and stream chemistry that are not readily discerned from sparser sampling.

Throughout the northeastern United States, atmospheric N deposition has affected soil N status, biological cycling, and stream nitrate concentrations (Aber et al. 2003). At W-9, the average total N input from 1978 to 1998 of $13.2 \text{ kg ha}^{-1} \text{ y}^{-1}$ (Campbell et al. 2004) is among the highest in the nation. Understanding the direct effects of N deposition on stream chemistry is complex because biological cycling retains N in organic matter and may re-emit N species back to the atmosphere via nitrification and denitrification. Additionally, atmospheric N deposition affects soil N status which has an indirect effect when N from atmospheric sources cascades through organic matter pools is subsequently nitrified in catchment soils and is then transported to streams.

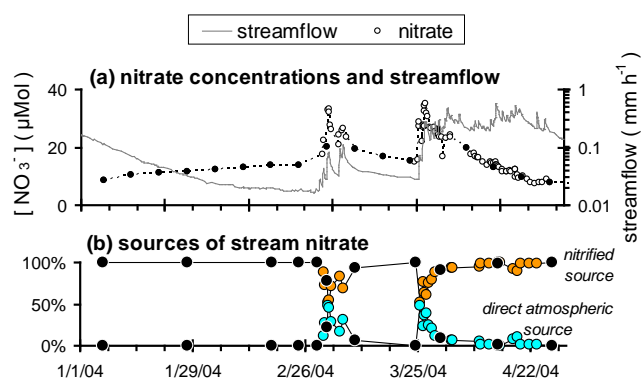

Figure 2. Stream nitrate concentrations at W-9 (A) and source apportionment (B) during winter and spring snowmelt 2004. The weekly-only samples are shown by the solid black symbols.

For atmospheric nitrate to directly affect streams, the atmospheric deposition must have a high concentration and the atmospherically-deposited nitrate must be rapidly transported through a watershed to a stream without being retained or biologically processed. High-frequency hydrochemical and isotopic data are needed to apportion how direct atmospheric sources affect stream nitrate loadings (Kendall et al. 2007). Recently, high-resolution temporal sampling has shown that the direct transport of atmospheric nitrate to the W-9 stream during spring snowmelt events has pronounced effects that were not previously quantified and that a fraction of the atmospheric nitrate inputs may be exported from watersheds without being transformed or retained by biological uptake (Ohte et al. 2004, Sebestyen et al. 2008). For example, direct atmospheric contributions as large as 49 percent at peak concentration during spring snowmelt mixed with a soil nitrified source that was flushed to the W-9 stream during stormflow (Figure 2).

During snowmelt, samples were often collected daily or at shorter intervals ranging from tens of minutes to hours. With only weekly data (solid black circles in Figure 2), the direct contribution of atmospheric nitrate to stream waters may have been missed.

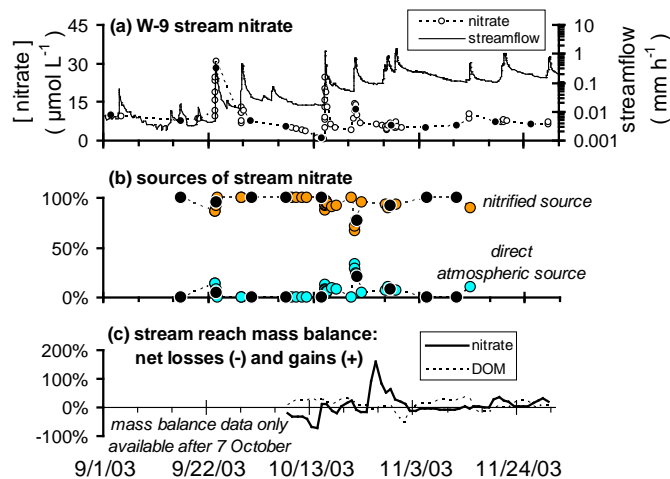

Figure 2. Nitrate concentrations (A), apportioned sources of stream nitrate (B), and nitrate and DOC losses and gains in the stream reach (C) at W-9 during autumn 2003. Weekly samples are indicated with solid black symbols.

High-frequency sampling during autumn revealed direct atmospheric contributions to the stream as large as 30 percent during stormflow (Figure 3)—another example of the effects of atmospheric deposition on stream chemistry that differs from base flow conditions. During base flow, stream nitrate originated from a nitrified source showing that the N had been microbially processed in the ecosystem (Figures 2, 3). Dynamics of nitrogen cycling may also be revealed with high-frequency samples. For example, litter inputs increase dissolved organic matter (DOM) concentrations and bioavailability in streams during autumn (Meyer et al. 1998) and should affect the cycling of stream nitrate. With daily samples, we detected transformations during base flow that were a seasonal response to the changing availability of nutrients during leaf fall. A mass balance shows up to 70 percent net retention of nitrate and the net production of dissolved organic carbon in a stream reach between the W-9 gage and the three upstream tributaries during base flow. The instream losses of nitrate and production of DOC show a “hot moment” of biogeochemical transformations that may not have been detected with weekly-only samples while the transport of atmospheric nitrate to streams shows the importance

of high-frequency sampling during short-duration stormflow events.

Large stormflow events, such as spring snowmelt, significantly contribute to the annual stream nitrate budget and the direct yield of nitrate from an atmospheric source is only a small fraction of the stream nitrate budget (Sebestyen et al. 2008). Between January and April the direct yields from atmospheric sources were 7 percent in both 2003 and 2004 (Figure 4). However, these small quantifiable yields provide an important baseline from which to assess future effects of nitrogen pollution on upland forested watersheds where atmospheric nitrogen deposition is chronic.

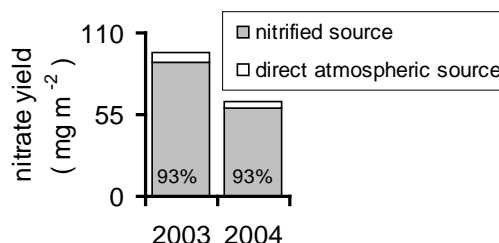

Figure 3. Isotopically apportioned nitrate yields from 1 January to 30 April show that 7 percent of the total stream nitrate originated directly from atmospheric nitrate deposition in both 2003 and 2004.

Like N deposition, the effects of Hg deposition are widespread in the northeastern United States (Driscoll et al. 2007). Mercury inputs accumulate in soils and are transported to surface waters. At Sleepers River, the average annual total Hg deposition is $25.1 \mu\text{g m}^{-2}$ (Shanley et al. 2008). At W-9, Hg concentrations exponentially increase during stormflow (Schuster et al. 2008) and elevated Hg fluxes during stormflow dominate the annual budget (Shanley et al. 2008). For example, after seven weeks of dry conditions, Hg was flushed to the stream during an intense rain storm on 15 September 2002 (Figure 5). Because stream Hg concentrations consistently increase during stormflow, Hg export is highly episodic throughout the year and fluxes of total and methyl Hg would be grossly underestimated if events were ignored (Shanley et al. 2008). Furthermore, Hg export is tightly coupled with DOM export (Shanley et al. 2008) which provides another example of coupled element cycles and pollutant transport to streams.

Linkages between DOM and other solute dynamics highlight a need to quantify DOM flushing from catchment soils to streams. Throughout northern North America and northern Europe, stream DOM

concentrations and loadings have increased in many ecosystems where drivers of environmental change such as pollutant inputs via atmospheric deposition and climate change affect northern forests (Goodale et al. 2005, Monteith et al. 2007).

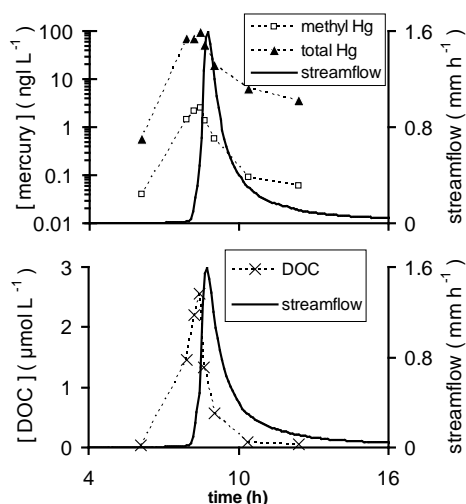

Figure 5. Increased total and methyl Hg concentrations during the 15 September 2002 storm reflect a legacy of atmospheric Hg deposition in watersheds. Note the log scale on the mercury concentrations. Increased Hg concentrations are highly associated with DOC that is flushed to streams during stormflow events.

Annual nutrient budgets show that large amounts of water, nitrate, DOM, and Hg are exported from catchments during infrequent but large stormflow events (Figure 6). This flow-stratified distribution of water and solute fluxes suggests that rapid and large magnitude transport to streams during stormflow is important.

If the climate of the northeastern United States changes consistent with projections (Hayhoe et al. 2007), we hypothesize that DOM transport to streams will increase because the frequency of large magnitude storm events is expected to increase. Because DOM is related to both nitrate and Hg, increased DOM fluxes will affect the hydrological flushing of Hg as well as the cycling, availability, and export of nitrate.

Implications for Watershed Studies

Targeted high-frequency hydrochemical sampling provides basic information that is needed to assess stream solute responses to drivers of environmental change such as atmospheric deposition and climate

change that affect forested watersheds. Examples from the Sleepers River Research Watershed illustrate how high-temporal resolution sampling in small watershed studies can be used to elucidate effects of atmospheric pollutants on stream chemistry while providing valuable information to inform land managers and environmental regulators. This sampling approach may increase our understanding of how atmospheric pollutants accumulate and flow through forested watersheds, especially as new hydrochemical and isotopic tracing techniques become available.

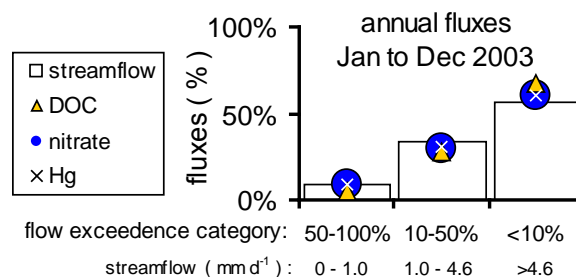

Figure 6. Large magnitude fluxes of water, nitrate, Hg, and DOC occur during short periods of high stormflow (i.e., the flows that are exceeded less than 10 percent of the time).

Acknowledgments

This work was funded by a U.S. Environmental Protection Agency STAR graduate fellowship (U-916154); the American Geophysical Union Hydrology Section Horton Research Grant; the Edna B. Sussman Fund; a U.S. Department of Agriculture Cooperative State Research, Education, and Extension Service Grant; the U.S. Geological Survey Water, Energy, and Biogeochemical Budget program; and the U.S. Geological Survey National Research Program. This article has not been formally reviewed by the EPA.

References

Aber, J.D., C.L. Goodale, S.V. Ollinger, M.-L. Smith, A.H. Magill, M.E. Martin, R.A. Hallett, and J.L. Stoddard. 2003. Is nitrogen deposition altering the nitrogen status of northeastern forests? *BioScience* 53:375–389.

Boyer, E.W., G.M. Hornberger, K.E. Bencala, and D.M. Mcknight. 2000. Effects of asynchronous snowmelt on flushing of dissolved organic carbon: A

- mixing model approach. *Hydrological Processes* 14:3,291–3,308.
- Burns, D.A. 2005. What do hydrologists mean when they use the term flushing? *Hydrological Processes* 19:1,325–1,327.
- Campbell, J.L., J.W. Hornbeck, M.J. Mitchell, M.B. Adams, M.S. Castro, C.T. Driscoll, J.S. Kahl, J.N. Kochenderfer, G.E. Likens, J.A. Lynch, P.S. Murdoch, S.J. Nelson, and J.B. Shanley. 2004. Input-output budgets of inorganic nitrogen for 24 forest watersheds in the northeastern United States: A review. *Water, Air, and Soil Pollution* 151:373–396.
- Creed, I.F., L.E. Band, N.W. Foster, I.K. Morrison, J.A. Nicolson, R.G. Semkin, and D.S. Jeffries. 1996. Regulation of nitrate-N release from temperate forests: A test of the N flushing hypothesis. *Water Resources Research* 32:3,337–3,354.
- Driscoll, C.T., Y.-J. Han, C.Y. Chen, D.C. Evers, K.F. Lambert, T.M. Holsen, N.C. Kamman, and R.K. Munson. 2007. Mercury contamination in forest and freshwater ecosystems in the northeastern United States. *BioScience* 57:1–28.
- Driscoll, C.T., D.R. Whittall, J.D. Aber, E.W. Boyer, M.S. Castro, C.S. Cronan, C.L. Goodale, P.M. Groffman, C.S. Hopkinson, K.F. Lambert, G.B. Lawrence, and S.V. Ollinger. 2003. Nitrogen pollution in the northeastern United States: Sources, effects, and management options. *BioScience* 53:357–374.
- Goodale, C.L., J.D. Aber, P.M. Vitousek, and W.H. McDowell. 2005. Long-term decreases in stream nitrate: Successional causes unlikely—Possible links to DOC? *Ecosystems* 8:334–337.
- Hayhoe, K., C.P. Wake, T.G. Huntington, L. Luo, M.D. Schwartz, J. Sheffield, E. Wood, B. Anderson, J. Bradbury, A. Degaetano, T.J. Troy, and D. Wolfe. 2007. Past and future changes in climate and hydrological indicators in the US Northeast. *Climate Dynamics* 28:381–407.
- Kendall, C., S.D. Wankel, and E.M. Elliott. 2007. Tracing Anthropogenic Inputs of Nitrogen to Ecosystems. In R.H. Michener and K. Lajtha, eds., *Stable Isotopes in Ecology and Environmental Science*, pp. 375–449. Blackwell Scientific, New York.
- Meyer, J.L., J.B. Wallace, and S.L. Eggert. 1998. Leaf litter as a source of dissolved organic carbon in streams. *Ecosystems* 1:240–249.
- Monteith, D.T., J.L. Stoddard, C.D. Evans, H.A. Dewit, M. Forsius, T. Hogasen, A. Wilander, B.L. Skjelkvale, D.S. Jeffries, J. Vuorenmaa, B. Keller, J. Kopacek, and J. Vesely. 2007. Dissolved organic carbon trends resulting from changes in atmospheric deposition chemistry. *Nature* 450:537–540.
- Ohte, N., S.D. Sebestyen, C. Kendall, J.B. Shanley, S.D. Wankel, D.H. Doctor, and E.W. Boyer. 2004. Tracing sources of nitrate in snowmelt runoff using a high-resolution isotopic technique. *Geophysical Research Letters* 31:L21506.
- Schuster, P.F., J.B. Shanley, M. Marvin-Dipasquale, M.M. Reddy, G.R. Aiken, D.A. Roth, H.E. Taylor, D.P. Krabbenhoft, and J.F. Dewild. 2008. Mercury and organic carbon dynamics during runoff episodes from a northeastern USA watershed. *Water, Air, and Soil Pollution* 187:89–108.
- Sebestyen, S.D., E.W. Boyer, J.B. Shanley, C. Kendall, D.H. Doctor, G.R. Aiken, and N. Ohte. 2008. Sources, transformations, and hydrological processes that control stream nitrate and dissolved organic matter concentrations during snowmelt in an upland forest. *Water Resources Research* 44:W12410.
- Shanley, J.B., M.A. Mast, D.H. Campbell, G.R. Aiken, D.P. Krabbenhoft, R.J. Hunt, J.F. Walker, P.F. Schuster, A. Chalmers, B.T. Aulenbach, N.E. Peters, M. Marvin-Dipasquale, D.W. Clow, and M.M. Shafer. 2008. Comparison of total mercury and methylmercury cycling at five sites using the small watershed approach. *Environmental Pollution* 154:143–154.

Flowpath Contributions of Weathering Products to Stream Fluxes at the Panola Mountain Research Watershed, Georgia

Norman E. Peters, Brent T. Aulenbach

Abstract

Short-term weathering rates (chemical denudation) of primary weathering products were derived from an analysis of fluxes in precipitation and streamwater. Rainfall, streamflow (runoff), and related water quality have been monitored at the Panola Mountain Research Watershed (PMRW) since 1985. Regression relations of stream solute concentration of major ions including weathering products [sodium (Na), magnesium (Mg), calcium (Ca) and silica (H_4SiO_4)] were derived from weekly and storm-based sampling from October 1986 through September 1998; runoff, seasonality, and hydrologic state were the primary independent variables. The regression relations explained from 74 to 90 percent of the variations in solute concentration. Chloride (Cl) fluxes for the study period were used to estimate dry atmospheric deposition (DAD) by subtracting the precipitation flux from the stream flux; net Cl flux varied from years of net retention during dry years to >3 times more exported during wet years. On average, DAD was 56 percent of the total atmospheric deposition (also assumed for the other solutes); average annual net cation and H_4SiO_4 fluxes were 50.6 and 85.9 $mmol\ m^{-2}$, respectively. The annual cumulative density functions of solute flux as a function of runoff were evaluated and compared among solutes to evaluate relative changes in solute sources during stormflows. Stream flux of weathering solutes is primarily associated with groundwater discharge. During stormflow, Ca and Mg contributions increase relative to Na and H_4SiO_4 , particularly during wet years when the contribution is 10 percent of the annual flux. The higher Ca and Mg contributions to the stream during stormflow are consistent with increased contribution from shallow soil horizons where these solutes dominate.

Peters and Aulenbach are research hydrologists, both with the U.S. Geological Survey Georgia Water Science Center, 3029 Amwiler Rd., Suite 130 Atlanta, GA 30360. Email: nepeters@usgs.gov; btaulenb@usgs.gov.

Keywords: weathering, hydrologic pathways, biogeochemistry, chemical denudation

Introduction

Chemical denudation and, in some cases, the rates of mineral weathering have been estimated from mass balance for forested small catchments (Johnson et al. 1968; Paces 1985, 1986; Velbel 1985; April et al. 1986; Peters et al. 2006). Weathering rates for some minerals, e.g. feldspar, have been attributed to hydrologic controls (Velbel 1993, White et al. 2001), whereas the weathering rates of other minerals, e.g. biotite, have been attributed to kinetic controls (White et al. 2002). These studies evaluate fluxes, which typically are bounded by atmospheric deposition inputs and streamwater outputs (Bluth and Kump 1994, Oliva et al. 2003), changes in soil solution and mineral and elemental changes in soils and bedrock (White et al. 2001, 2002), or a combination of fluxes and changes in solutions and solid phases (Paces 1985, 1986; April et al. 1986; Velbel 1985, 1993; Huntington et al. 2000). Solid-phase chemical and mineralogical changes reflect long-term weathering, whereas soil solution and input-output fluxes reflect both short and long-term weathering while being sensitive to short-term “readjustments” of exchangeable ions caused by changes in the composition of atmospheric deposition (Paces 1985, 1986; Huntington 2000). Temporal and spatial variations in hydrologic conditions affect fluxes, and therefore the interpretation of short-term chemical denudation rates. Can hydrochemical characteristics and variations in streamwater and soil solutions allude to processes, i.e., solute sources and transport controlling the short-term chemical denudation rates?

A weathering profile at the Panola Mountain Research Watershed (PMRW) shows large changes in mineral and elemental composition with depth to approximately 9.5 m (4.5 m soil and 5 m bedrock), which reflects

long-term weathering of the underlying Panola Granite (White et al. 2001, 2002). The chemistry of surface-horizon soil solutions differs significantly from the solid phase chemistry and reflects typical biogeochemical cycling by the forest and cation exchange in the soil (Peters and Ratcliffe 1998, White et al. 2001). The surface soil solutions are enriched in calcium (Ca), magnesium (Mg), and potassium (K) compared with soil solutions lower in the profile (Hooper et al. 1990, Peters and Ratcliffe 1998). In contrast, dissolved silica (H_4SiO_4) and sodium (Na) are minimally affected by biogeochemical cycling and ion exchange, and their concentrations increase progressively with depth below the land surface and also increase with residence time in groundwater (Peters and Ratcliffe 1998, Burns et al. 2003).

Base cations (Ca, Mg, and Na) and H_4SiO_4 concentrations dilute as runoff increases during rainstorms at PMRW (Peters 1994). Hooper et al. (1990) showed the general dominance of a groundwater source, which was augmented by hillslope water when the watershed was wet and by shallow soil water when the watershed was dry. A follow-up end-member mixing analysis by Hooper (2001) showed a pronounced temporal change in the end-member solute composition. Hooper (2001) concluded that the hillslope end member, which represents approximately 85 percent of the watershed (Freer et al. 2002), is not chemically expressed in the stream and that the stream chemical dynamics largely reflect the relative contribution of different parts of the riparian area and not the workings of the catchment as a whole.

Streamwater sources change during rainstorms. Hydrologic processes at PMRW are nonlinear during rainstorms, but maximum groundwater levels, maximum soil moisture content, and stormflow water yields are linearly related to each other above a wetness threshold (Peters et al. 2003, Tromp-van Meerveld and McDonnell 2006). The general relations among streamflow, soil moisture, and water table response are attributed to variable source areas, particularly the groundwater contribution from a riparian-zone aquifer ≤ 5 m thick that expands as the watershed becomes wetter, and to subsurface translatory flow during rainstorms (Hewlett and Hibbert 1967).

Perturbations to the long-term chemical/weathering evolution of the watershed likely have occurred because of agricultural land abandonment in the early 1900s

(Huntington et al. 2000) and to changes in atmospheric deposition since 1900, such as increases in **acid rain** (rainfall pH at PMRW averages in the low 4s; Peters et al. 2002); SO_4^{2-} mobilization causes leaching of cations from soil exchange sites (Huntington et al. 2000). This process should approach a steady state with respect to inputs and outputs of SO_4^{2-} . For PMRW, the chemical readjustment of the watershed to SO_4^{2-} inputs will be slow because the soils in the Southeast strongly adsorb SO_4^{2-} (Shanley 1992). During the last two decades, sulfate is being mobilized at PMRW during rainstorms despite an annual retention of 80–90 percent of the SO_4^{2-} (Huntington et al. 1994, Peters et al. 2003).

The objective of this paper is to present results of an annual chemical denudation analysis and a preliminary investigation of changes in mobility and hydrologic flow path contributions of base cations and H_4SiO_4 with respect to runoff and general wetness condition. The analysis focuses on stream base cation and H_4SiO_4 concentrations and relative cumulative flux distributions.

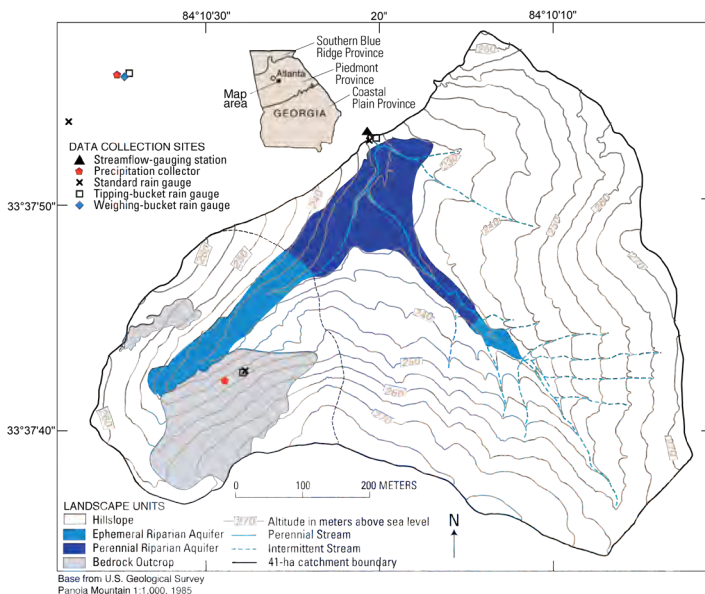

Figure 1. Map of the Panola Mountain Research Watershed, Georgia.

Site description

The PMRW is in the Panola Mountain State Conservation Park, in the Piedmont of Georgia, United States ($84^{\circ}10'W$, $33^{\circ}37'N$) (Figure 1), located 25 km southeast of Atlanta. The climate is humid continental to subtropical. A long growing season, warm temperatures, and many sunny days result in high rates

of evapotranspiration (ET), particularly during summer. Air temperature averages 15.2°C annually, and the average monthly temperatures range from 5.5°C during January to 25.2°C during July. During WY1986–2001 (WY1986: 1 October 1985 through 30 September 1986), annual precipitation averaged 1,220 mm and ranged from approximately 760 to 1,580 mm; less than 1 percent of the precipitation occurred as snow; annual runoff averaged 377 mm and ranged from approximately 150 to 700 mm; and annual water yield averaged 30 percent and ranged from 16 to 50 percent (Peters et al. 2003). Winter frontal systems provide long, typically low-intensity rainstorms in contrast to short intense convective thunderstorms that occur during the spring and summer from April through September.

The PMRW is covered with a mixed deciduous and coniferous forest; the oldest deciduous trees are approximately 130 years old and the oldest coniferous trees are approximately 70 years old (Cappellato 1991).

The dominant bedrock at PMRW is the 320-Myr-old Panola Granite, a biotite-oligoclase-quartz microcline granodiorite, which contains pods of amphibolitic gneiss, particularly at lower elevation (Higgins et al. 1988).

Methods

The results presented herein are from analyses of samples collected at a compound V-notch weir at the basin outlet during WY1986–1998. Discharge at the weir was determined from a stage-discharge rating and stage measurements recorded by a datalogger using a potentiometer and a float-counterweight system. Weekly manual samples (965) were augmented by samples collected during rainstorms (1,922) using a stage-activated automatic sampler (Peters 1994).

Rainfall quality was measured in samples collected weekly using Aerochem Metrics Model 301 wet

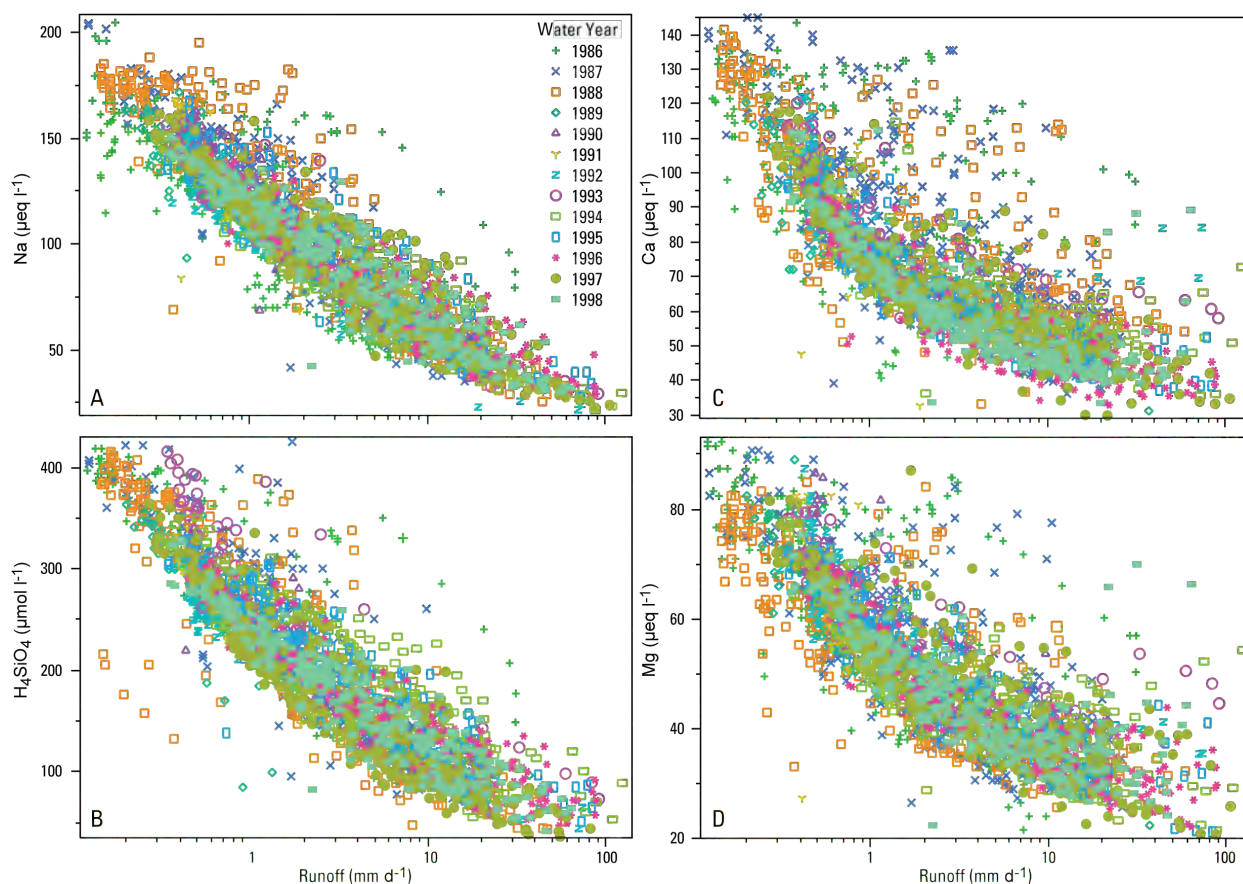

Figure 2. Relation between runoff and (A) sodium, Na; (B) dissolved silica, H_4SiO_4 ; (C) calcium, Ca; and (D) magnesium, Mg, concentration during WY1986–1998.

precipitation collectors following National Atmospheric Deposition Program/National Trends Network protocols (Dossett and Bowersox 1999). In addition to the measured volume of the rainfall sample, 1-min rainfall totals measured to the nearest 0.25 mm were recorded for each of several tipping-bucket rain gauges (Figure 1).

Streamwater and precipitation samples were analyzed in the laboratory for pH, specific conductance, and major solutes. The samples were refrigerated upon receipt in the laboratory until the time of analysis. The major solutes, including sodium (Na), calcium (Ca), magnesium (Mg), and potassium (K), were determined by ion chromatography before 1992 and by direct current plasma during and after 1992; chloride (Cl) and sulfate (SO_4) were determined by ion chromatography.

Flux computation

Solute loadings in precipitation were computed by multiplying the solute concentration by the volume of the sample divided by the collection area. A composite method was used to estimate stream solute fluxes. The composite method combines elements of the regression model method and the period weighting approach (Aulenbach and Hooper 2006). The regression model component estimates short-term variations in solute concentrations between sample observations based on known relations with continuous variables such as discharge and season. The residual flux portion of the flux uses a period weighted approach to correct the regression model to the actual sample concentration by adjusting the model concentration by the residual concentration at the time of sampling and applying the error between sampling times in a piecewise linear fashion. The concentration–discharge relation is modeled using a hyperbolic function (Johnson et al. 1968). This functional form fits the data in this study well. In the hyperbolic model, the best discharge averaging period, i.e., preceding the time of sample collection, was 15 min for Na, Cl, and H_4SiO_4 , 30 min for Mg, and 12 hr for Ca. Seasonal variations in concentration were modeled using sine and cosine functions. One-year and half-year periods were used for sine and cosine terms to fit asymmetrical annual cycles.

Results and Discussion

Streamwater concentrations of Ca, Mg, Na, and H_4SiO_4 are strongly correlated with discharge (or runoff, expressed in mm d^{-1}) and the regression models explain

most of the concentration variation with 74, 78, 89, and 90 percent of the variation explained, respectively. Furthermore, there was no change detected in the relation between concentration and runoff from year to year (Figure 2). Potassium was not included in the detailed analysis: K is very active in forest biogeochemical cycling (Likens et al. 1994), K

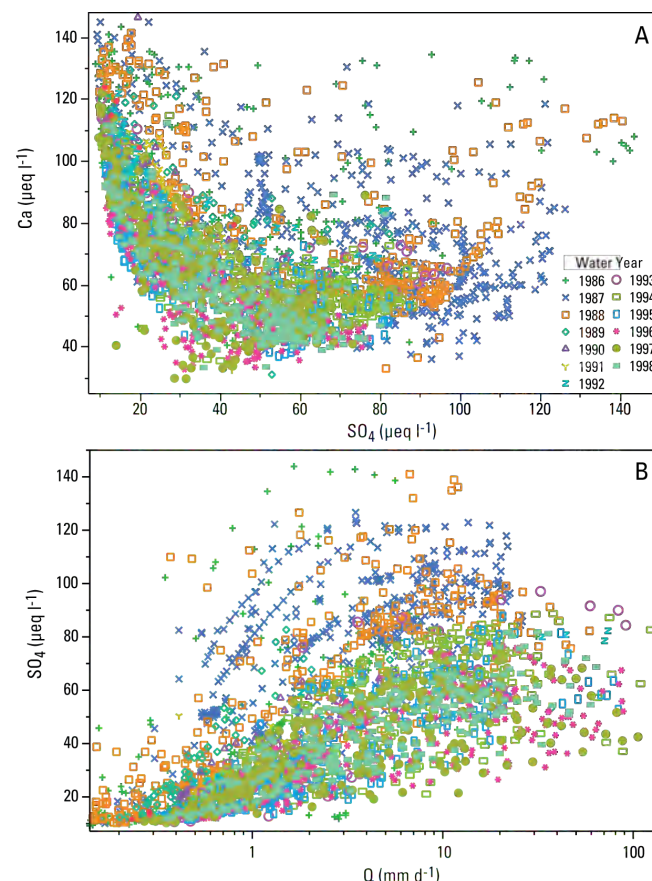

Figure 3. Relations between (A) Ca and SO_4 concentration, and (B) SO_4 concentration and runoff subdivided by water during WY1986–1998.

concentrations were low compared to the other base cations, and were not highly correlated with runoff, nor did the regression model explain much of the concentration variation (32 percent). The concentration–runoff relation is strongest for Na and H_4SiO_4 , and the relation is more curvilinear, i.e., concentration versus base10 logarithm of runoff, for Ca and Mg. Concentrations for Ca and Mg are relatively higher at higher runoff than can be explained by the dilution of groundwater, i.e., the mixing of two components, dilute **new** water with **old** groundwater (Hooper et al 1990). The relative Ca increase with increasing flow suggests that Ca is mobilized from another source. This increase in Ca and Mg can be

explained by the mobility of SO_4 . The relation between Ca and SO_4 is not highly significant, but it shows a general pattern of decreasing Ca with increasing SO_4 through a minimum at SO_4 of approximately $40 \mu\text{eq L}^{-1}$, followed by an increase in Ca and SO_4 (Figure 3A). This result is consistent with the hypothesis that cations are depleted from exchange sites in the upper soil horizons due to the mobility of SO_4 , which occurs during rainstorms (Figure 3B). The highest Ca at the lowest runoff and concurrent lowest SO_4 concentration are consistent with a groundwater source.

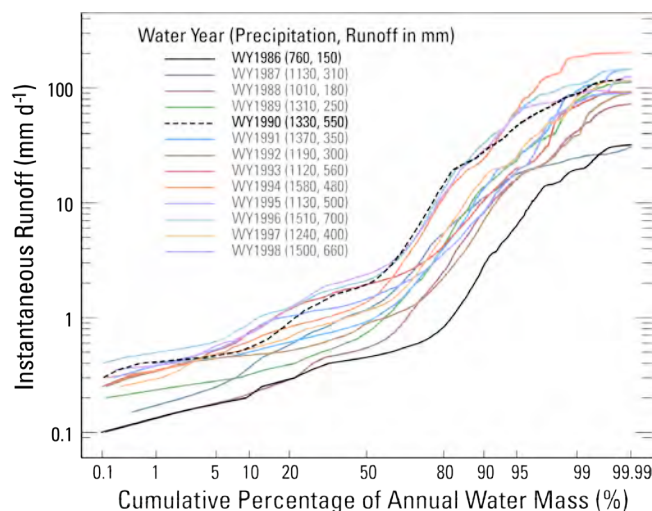

Figure 4. Cumulative distribution of annual water flux with respect to runoff during WY1985–1998.

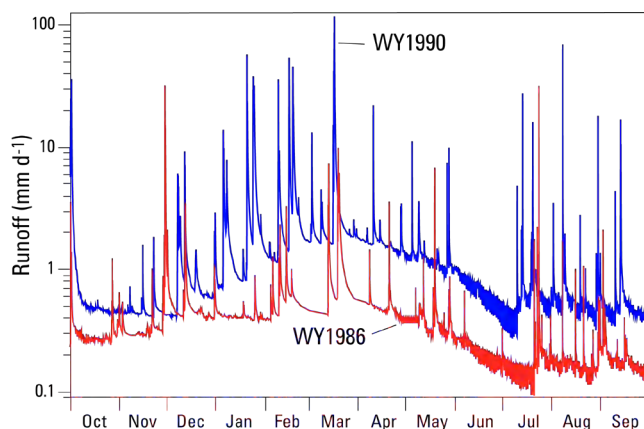

Figure 5. Runoff hydrographs at PMRW during WY1986 and WY1990.

The interannual cumulative probability distribution of water flux varied markedly among years (Figure 4). During a dry year (WY1986), most of the water was transported during base flow periods with only less than 20 percent being transported during rainstorms, i.e., higher runoff; precipitation was 760 mm and runoff was 150 mm. In contrast, during a wet year (WY1990),

approximately 60 percent of the water was transported during base flow; precipitation was 1,330 mm and runoff was 550 mm. Maximum runoff during base flow periods was higher during the wet WY than during the dry WY (approximately 2 compared to 0.4 mm d^{-1}). Also, the maximum base flow, which occurs during the winter dormant season, was much lower during WY1986 ($0.5\text{--}0.6 \text{ mm d}^{-1}$) than WY1990 (approximately 1.8 mm d^{-1}), and fewer major rainstorms occurred during WY1986 (Figure 5).

Cumulative H_4SiO_4 (and Na) and Ca fluxes were markedly different for the two WYs, reflecting the effect of stormflow and associated change in hydrological pathway contributions on solute transport (Figure 6). The similarity and dominance of base flow in water transport during the WY1986 suggests that most of the Ca, Na, and H_4SiO_4 flux was contributed by groundwater. During WY1990, however, there is a noticeable shift in the response at higher runoff.

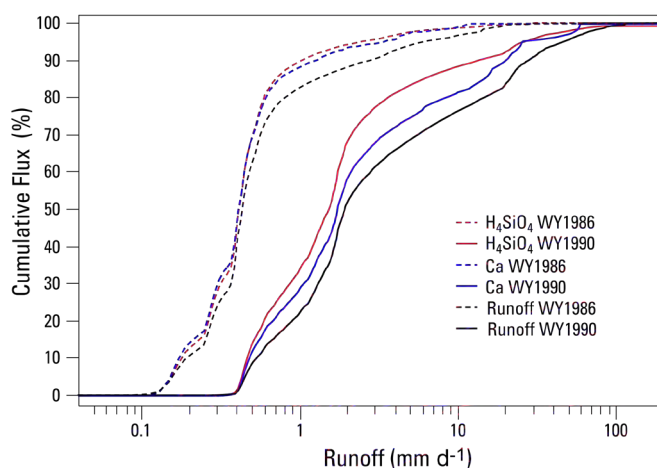

Figure 6. Cumulative density functions of runoff and stream Ca and H_4SiO_4 flux during WY1986 and WY1990.

A comparison of the differences in the constituent flux distributions (subtracting Ca from H_4SiO_4) across runoff alludes to hydrochemical processes. The observed H_4SiO_4 excess indicates that the Ca is derived from a different source than H_4SiO_4 . The maximum difference for the wet year is approximately 10 percent at high runoff (Figure 7). Because H_4SiO_4 is derived from weathering and is highly correlated with residence time, groundwater is the primary and likely the only source. Likewise, in subtracting Na from H_4SiO_4 flux, very small differences are noted in either the wet or dry WYs, consistent with a groundwater source for Na and H_4SiO_4 . The 10-percent H_4SiO_4 –Ca difference is

attributed to the mobilization of Ca during rainstorms from either cation exchange sites in the upper soil horizons or possibly enriched soil solutions as a result of biogeochemical cycling by the forest. In addition, maximum H_4SiO_4 -Ca flux difference varied from year to year, but it was highly correlated with annual runoff (Figure 8). These relations suggest the importance of hydrological processes in solute transport.

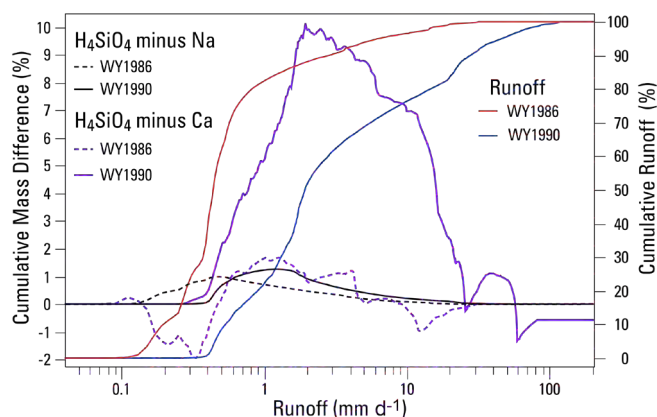

Figure 7. Cumulative density functions of the difference between H_4SiO_4 and Na and H_4SiO_4 and Ca versus runoff during WY1986 and WY1990.

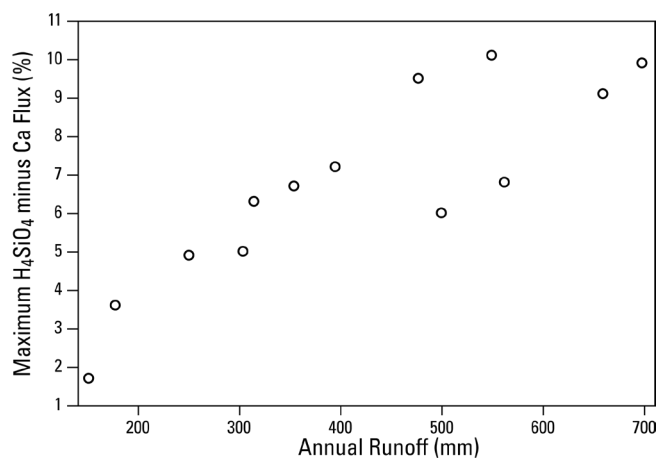

Figure 8. Maximum difference in the annual cumulative density functions between H_4SiO_4 and Ca flux versus runoff during WY1986–1998.

Groundwater discharge is the sole contributor to runoff during base flow, but as the watershed becomes wetter during rainstorms and runoff increases, some of the runoff is hypothesized to be derived from flow through the unsaturated zone, particularly in the riparian zone (Hooper et al. 1990, Hooper 2001, Peters et al. 2003, Burns et al. 2001 and 2003, Tromp van Meerveld and McDonnell 2006).

The solute composition of soil solutions and streamwater support this result (Figure 9). Soil solutions are relatively more enriched in Ca in the upper soil horizons and depleted in H_4SiO_4 (Figure 9A), which is consistent with the relation between H_4SiO_4 and residence time reported for groundwater at PMRW (Burns et al. 2003). Soil solution Na and H_4SiO_4 concentrations increase with increasing depth and presumably residence time. In contrast, streamwater Na and H_4SiO_4 concentrations are highest during base flow, and as observed with the flux estimates, Ca (and Mg) are relatively more enriched at higher runoff (Figure 9B).

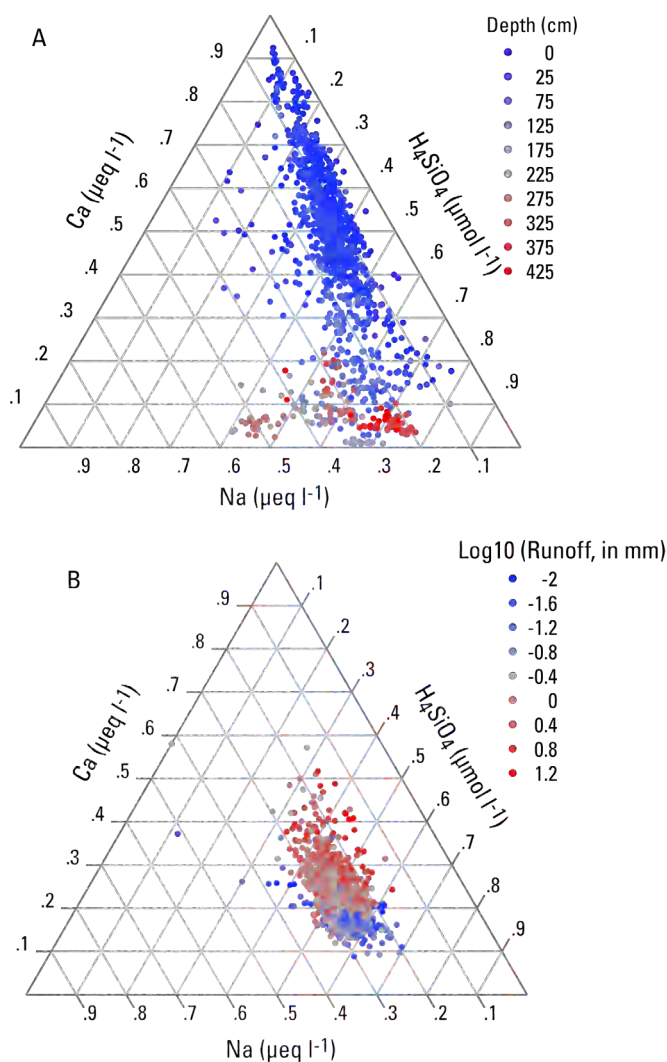

Figure 9. Ternary plot of Ca, Na, and H_4SiO_4 concentrations in (A) soil solution and (B) streamwater. The soil solution analyses are shaded by depth of the sampler below land surface. The streamwater analyses are shaded by the base10 logarithm of the instantaneous runoff.

Annual solute fluxes

The annual stream Cl flux (O, output) varied markedly and, when compared to the annual precipitation Cl flux (I, input), ranged from years with net retention (I/O = 1.13) to years with much higher output than input (I/O = 0.28). These differences are attributed to variations in the mobilization of wet and dry atmospheric Cl deposition, which is the main source of Cl to the watershed (Peters and Ratcliffe 1998). Assuming that the Cl is conservative and mobile with no internal watershed source, dry Cl deposition, on average, was 56 percent of the total deposition during WY1986–1998, i.e., the net flux was zero for the study period. The 56 percent dry deposition estimate was used to compute the dry deposition of cations, SO₄ and H₄SiO₄ (Table 1). Chemical denudation, on average, accounts for net cation and H₄SiO₄ fluxes of 50.6 and 85.9 mmol m⁻², respectively. These solute fluxes are comparable to those reported for other temperate streams underlain by granitoid rocks (Bluth and Kump 1994, Oliva et al. 2003).

Table 1. Average annual solute fluxes during WY1986–1998 at PMRW; atmospheric deposition includes both wet and dry deposition.

Solute	Flux (mmol m ⁻² , kg ha ⁻¹)		
	Atmospheric deposition	Stream	Net
Ca	4.7 (1.9)	14.4 (5.8)	9.7 (3.9)
Mg	1.6 (0.4)	10.5 (2.5)	8.8 (2.1)
Na	15.5 (3.6)	40.7 (9.4)	25.3 (5.8)
K	2.7 (1.0)	9.5 (3.7)	6.8 (2.7)
Cations	24.5 (6.9)	75.1 (21.4)	50.6 (14.5)
H ₄ SiO ₄ (as Si)	0 (0)	85.9 (24.0)	85.9 (24.0)
Cl	16.7 (5.9)	16.7 (5.9)	0 (0)
SO ₄	45.8 (44.0)	8.6 (8.3)	-37.2 (-35.7)

Conclusions

Precipitation and stream fluxes of the primary weathering products (sodium, calcium, magnesium and silica) were evaluated from October 1985 through September 1998 at the relatively undisturbed, small (0.41 km²) forested Panola Mountain Research Watershed (PMRW), GA. Rainfall, streamflow (runoff), and related water quality have been monitored at PMRW since 1985. Regression relations of stream solute concentrations were derived from weekly and storm-based sampling. Runoff, seasonality, and hydrologic state were the primary independent

variables. These relations were statistically significant and explained from 74 to 90 percent of the variations in solute concentration.

Streamwater solute fluxes were evaluated with respect to annual precipitation and runoff characteristics, including water fluxes and water yield. Stream solute fluxes were computed from the concentration predicted by the regression relations and runoff. Precipitation fluxes were computed from the weekly water-quality samples and gauged precipitation. In addition, annual precipitation chloride (Cl) flux was subtracted from the stream Cl flux to estimate dry deposition, assuming that there is no internal source of Cl and that Cl is mobile and conservative. Dry Cl deposition, on average, contributes 56 percent to the total atmospheric deposition, which also was applied to the other solutes. The average net annual cation and silica fluxes were 50.6 and 85.9 mmol m⁻², respectively.

The cumulative density functions (CDF) of solute and runoff flux as a function of runoff varied markedly among years and displayed a decrease in the contribution of base flow to annual flux during wet years. While streamwater flux of weathering solutes is primarily associated with base flow groundwater discharge, calcium and magnesium displayed a contribution during rainstorms particularly during wet years; e.g., 10 percent of the annual flux. Also, the maximum silica-minus-calcium CDF difference was positively correlated with annual runoff. The source is hypothesized to be mobilization from shallow soil horizons where these solutes dominate.

Acknowledgments

The study is part of the U.S. Geological Survey Water, Energy, and Biogeochemical Budgets Program and was conducted in cooperation with the Georgia Department of Natural Resources. The authors are grateful for the support provided by the staff of Panola Mountain State Park.

References

April, R., R. Newton, and L.T. Coles. 1986. Chemical weathering in two Adirondack watersheds: Past and present-day rates. *Geological Society of America Bulletin* 97(10):1,232–1,238.

- Aulenbach, B.T., and R.P. Hooper. 2006. The composite method: An improved method for streamwater solute load estimation. *Hydrological Processes* 20(14):3,028–3,047.
- Bluth, G.J.S., and L.R. Kump. 1994. Lithologic and climatologic controls of river chemistry. *Geochimica et Cosmochimica Acta* 58:2,341–2,359.
- Burns, D.A., J.J. McDonnell, R.P. Hooper, N.E. Peters, J.E. Freer, C. Kendall, and K. Beven. 2001. Quantifying contributions to storm runoff through end-member mixing analysis and hydrologic measurements at the Panola Mountain Research Watershed (Georgia, USA). *Hydrological Processes* 15(10):1,903–1,924.
- Burns, D.A., N. Plummer, J.J. McDonnell, E. Busenberg, G.C. Casile, C. Kendall, R.P. Hooper, J.E. Freer, N.E. Peters, K. Beven, and P. Schlosser. 2003. The geochemical evolution of riparian groundwater in a forested piedmont catchment. *Ground Water* 41(7):913–925.
- Cappellato, R. 1991. Acidic Atmospheric Deposition and Canopy Interactions of Adjacent Deciduous and Coniferous Forests in the Georgia Piedmont. Emory University. Ph.D. thesis. Atlanta, GA.
- Dossett, S.R., and V.C. Bowersox. 1999. National Trends Network site operation manual. National Atmospheric Deposition Program Office, Illinois State Water Survey, Manual 1999–01.
- Freer, J., K.J. Beven, and N. Peters. 2002. Multivariate seasonal and sub-period model rejection within the Generalised Likelihood Uncertainty Estimation procedure. In Q. Duan, S. Sorooshian, H. Gupta, A.N. Rousseau, and R. Turcotte, eds., *Calibration of Watershed Models*, pp. 69–87. American Geophysical Union Monograph, Water Science and Applications Series 6.
- Hewlett, J.D., and A.R. Hibbert. 1967. Factors Affecting the Response of Small Watersheds to Precipitation in Humid Areas. In W.E. Sopper and H.W. Lull, eds., *Forest Hydrology*, pp. 275–290. Pergamon Press, Oxford, UK.
- Higgins, M.W., R.L. Atkins, T.J. Crawford, R.F. Crawford III, R. Brooks, and R. Cook. 1988. The structure, stratigraphy, tectonostratigraphy and evolution of the southernmost part of the Appalachian orogen. U.S. Geological Survey, Professional Paper 1475.
- Hooper, R.P. 2001. Applying the scientific method to small catchment studies: A review of the Panola Mountain experience. *Hydrological Processes* 15(10):2,039–2,050.
- Hooper, R.P., N. Christophersen, and N.E. Peters. 1990. Modelling streamwater chemistry as a mixture of soil-water end members: An application to the Panola Mountain watershed, Georgia, USA. *Journal of Hydrology* 116:321–343.
- Huntington, T.G., R.P. Hooper, and B.T. Aulenbach. 1994. Hydrologic processes controlling sulfate mobility in a small forested watershed. *Water Resources Research* 30:283–295.
- Huntington, T.G., R.P. Hooper, C.E. Johnson, B.T. Aulenbach, R. Cappellato, and A.E. Blum. 2000. Calcium depletion in a southeastern United States Forest Ecosystem. *Soil Science Society of America Journal* 64(5):1,845–1,858.
- Johnson, N.M., G.E. Likens, F.R. Bormann, and R.S. Pierce. 1968. Rate of chemical weathering of silicate minerals in New Hampshire. *Geochimica et Cosmochimica Acta* 32:531–545.
- Likens, G.E., C.T. Driscoll, D.C. Buso, T.G. Siccama, C.E. Johnson, G.M. Lovett, D.F. Ryan, T. Fahey, and W.A. Reiners. 1994. The biogeochemistry of potassium at Hubbard Brook. *Biogeochemistry* 25:61–125.
- Oliva, P., J. Viers, and B. Dupre. 2003. Chemical weathering in granitic environments. *Chemical Geology* 202:225–256.
- Paces, T. 1985. Sources of acidification in Central Europe estimated from elemental budgets in small basins. *Nature* 315(6014):31–36.
- Paces, T. 1986. Weathering rates of gneiss and depletion of exchangeable cations in soils under environmental acidification. *Journal of the Geological Society of London* 143:673–677.

- Peters, N.E. 1994. Water-quality variations in a forested piedmont catchment, Georgia, USA. *Journal of Hydrology* 156:73–90.
- Peters, N.E., J. Freer, and B.T. Aulenbach. 2003. Hydrologic dynamics of the Panola Mountain Research Watershed, Georgia, USA. *Ground Water* 41(7):973–988.
- Peters, N.E., T.P. Meyers, and B.T. Aulenbach. 2002. Status and trends in atmospheric deposition and emissions near Atlanta, Georgia, 1986–99. *Atmospheric Environment* 13(10):1,577–1,588.
- Peters, N.E., and E.B. Ratcliffe. 1998. Tracing hydrologic pathways using chloride at the Panola Mountain Research Watershed, Georgia, USA. *Water, Air and Soil Pollution* 105(1/2):263–275.
- Peters, N.E., J.B. Shanley, B.T. Aulenbach, R.M. Webb, D.H. Campbell, R. Hunt, M.C. Larsen, R.F. Stallard, J.W. Troester, and J.F. Walker. 2006. Water and solute mass balance of five small, relatively undisturbed watersheds in the U.S. *Science of the Total Environment* 358:221–242.
- Shanley, J.B. 1992. Sulfur retention and release in soils at Panola Mountain, Georgia. *Soil Science* 153(6):499–508.
- Tromp-van Meerveld, H.J. and J.J. McDonnell. 2006. Threshold relations in subsurface stormflow: 1. A 147-storm analysis of the Panola hillslope. *Water Resources Research* 42:W02410.
- Velbel, M.A. 1985. Geochemical mass balances and weathering rates in forested watersheds of the southern Blue Ridge. *American Journal of Science* 285:904–930.
- Velbel, M.A. 1993. Constancy of silicate-mineral weathering rate ratios between natural and experimental weathering: Implications for hydrologic control of differences in absolute rates. *Chemical Geology* 105:89–99.
- White, A.F., A.E. Blum, M.S. Schulz, T.G. Huntington, N.E. Peters, and D.A. Stonestrom. 2002. Chemical weathering of the Panola Granite: Solute and regolith elemental fluxes and the weathering rate of biotite. In R. Hellmann and S.A. Wood, eds., *Water-Rock Interactions, Ore Deposits, and Environmental Geochemistry: A Tribute to David A. Crerar*, pp. 37–59. The Geochemical Society, Special Publication No. 7.
- White, A.F., T.D. Bullen, M.S. Schulz, A.E. Blum, T.G. Huntington, and N.E. Peters. 2001. Differential rates of feldspar weathering in granitic regoliths. *Geochimica et Cosmochimica Acta* 65:847–869.

Responses of Benthic Macroinvertebrates to Urbanization in Nine Metropolitan Areas of the Conterminous United States

T.F. Cuffney, G. McMahon, R. Kashuba, J.T. May, I.R. Waite

Abstract

The effects of urbanization on benthic macroinvertebrates were investigated in nine metropolitan areas (Boston, MA; Raleigh, NC; Atlanta, GA; Birmingham, AL; Milwaukee–Green Bay, WI; Denver, CO; Dallas–Fort Worth, TX; Salt Lake City, UT; and Portland, OR) as a part of the U.S. Geological Survey National Water Quality Assessment Program. Several invertebrate metrics showed strong, linear responses to urbanization when forest or shrublands were developed. Responses were difficult to discern in areas where urbanization was occurring on agricultural lands because invertebrate assemblages were already severely degraded. There was no evidence that assemblages showed any initial resistance to urbanization. Ordination scores, EPT taxa richness, and the average tolerance of organisms were the best indicators of changes in assemblage condition at a site. Richness metrics were better indicators than abundance metrics, and qualitative samples were as good as quantitative samples. A common set of landscape variables (population density, housing density, developed landcover, impervious surface, and roads) were strongly correlated with urbanization and invertebrate responses in all non-agricultural areas. The instream environmental variables (hydrology, water chemistry, habitat, and temperature) that were strongly correlated with urbanization and invertebrate responses were influenced by environmental setting (e.g., dominant ecoregion) and varied widely among metropolitan areas. Multilevel hierarchical regression

Cuffney, McMahon, May, and Waite are research scientists, all with the U.S. Geological Survey, Water Resources Discipline. Kashuba is with Duke University, Durham, NC. T.F. Cuffney: 3916 Sunset Ridge Road, Raleigh, NC 27607. Email: tcuffney@usgs.gov.

models were developed that predicted invertebrate responses using only two landcover variables—basin-scale landcover (percentage of basin area in developed land) and regional-scale landcover (antecedent agricultural land).

Keywords: benthic macroinvertebrates, disturbance, landcover, water chemistry, urbanization, water quality

Introduction

Stream ecosystems are increasingly affected by urban development associated with human population growth (Booth and Jackson 1997, Paul and Meyer 2001, Walsh et al. 2001). Changes in landcover, hydrology, and impervious surfaces associated with urbanization alter the physical and chemical environment of streams and degrade invertebrate assemblages (Kennen 1999, Yoder et al. 1999, Huryn et al. 2002, Kennen and Ayers 2002, Morley and Karr 2002, Ourso and Frenzel 2003, Morse et al. 2003, Roy et al. 2003, Brown et al. 2005).

In 1999, the U.S. Geological Survey (USGS) initiated a series of urban stream studies as part of the National Water-Quality Assessment (NAWQA) Program. These studies are based on a common study design (McMahon and Cuffney 2000, Coles et al. 2004, Cuffney et al. 2005, Tate et al. 2005), consistent measures of urban intensity (Cuffney and Falcone 2008), and standard sample-collection and processing methods (Fitzpatrick et al. 1998, Moulton et al. 2002). Nine major metropolitan areas—Boston, MA (BOS); Raleigh, NC (RAL); Atlanta, GA (ATL); Birmingham, AL (BIR); Milwaukee–Green Bay, WI (MGB); Denver, CO (DEN); Dallas–Fort Worth, TX (DFW); Salt Lake City, UT (SLC); and Portland, OR (POR) (Figure 1)—were chosen to represent the effects of urbanization in regions of the country that differ in potential natural vegetation, temperature, precipitation, basin relief, elevation, and basin slope. The objectives of these

studies are to (1) determine the response of benthic macroinvertebrates to urbanization, (2) identify the landscape (census, landcover, and infrastructure) and instream (water chemistry, hydrology, habitat, and temperature) environmental variables that are strongly associated with urbanization and invertebrate responses, and (3) compare the similarities and differences in the process of urbanization and its effects among these nine metropolitan areas.



Figure 1. Locations of the nine metropolitan areas in which urban studies were conducted (shaded areas).

Methods

A population of candidate basins (typically basins drained by 2nd- to 3rd-order streams) was delineated within each of the nine metropolitan areas based on 30-m digital elevation models (U.S. Geological Survey 2003). Landcover, census, and infrastructure variables were summarized using nationally available databases in a geographic information system (GIS) (Falcone et al. 2007).

Urban intensity was defined by combining housing density, percentage of basin area in developed landcover, and road density into an index (metropolitan area national urban-intensity index, MA-NUII) scaled to range from 0 (little or no urban) to 100 (maximum urban) within each metropolitan area (Cuffney and Falcone 2008). Once groups of basins with relatively homogeneous environmental features were defined, 28–30 basins were selected to represent the gradient of urbanization in each metropolitan area. This spatially distributed sampling network represents changes in urbanization through time (i.e., substitute space for time).

The BOS, BIR, and SLC metropolitan areas were studied during 1999–2000; ATL, DEN, and RAL were studied during 2002–2003 and DFW, MGB, and POR in 2003–2004. Details of the study designs can be found in Coles et al. (2004), Tate et al. (2005), and Cuffney et al. (2005).

The NAWQA Program sampling protocols were used to collect benthic macroinvertebrates over a 1- to 4-week period during summer low base flows (Cuffney et al. 1993, Moulton et al. 2002). Quantitative (RTH) and qualitative multihabitat (QMH) samples were collected within each sampling reach. Samples were preserved in 10-percent buffered formalin and sent to the USGS National Water Quality Laboratory in Denver, CO, for taxa identification and enumeration (Moulton et al. 2000). The USGS Invertebrate Data Analysis System (IDAS; Cuffney 2003) was used to resolve taxonomic ambiguities and calculate assemblage metrics and diversity measures (Cuffney et al. 2007).

Water temperature, stream stage, water chemistry (nutrients, major ions, pesticides), dissolved oxygen, pH, and specific conductance were collected for about 1 year prior to the collection of biological samples (Cuffney and Brightbill 2008, Giddings et al. 2009). Water-column chemistry data were collected twice—once during high base flow (typically spring) and once during low base flow (typically summer) periods—using NAWQA Program sampling protocols (Shelton 1994; U.S. Geological Survey, variously dated). Samples were sent to the USGS National Water Quality Laboratory in Denver, CO, for analysis (Fishman and Friedman 1989, Brenton and Arnett 1993, Fishman 1993, Zaugg et al. 1995, U.S. Environmental Protection Agency 1997). Pesticide concentrations were weighted by toxicity to form an aggregate pesticide toxicity index (PTI; Munn and Gilliom 2001). Details on water-chemistry sampling can be found in Sprague et al. (2007) and Giddings et al. (2009). Water column chemistry measurements were supplemented with data from semipermeable membrane devices (SPMDs) that were used to collect hydrophobic organic compounds from water during a 4- to 6-week period in early to midsummer in RAL, ATL, MGB, DEN, DFW, and POR (Bryant et al. 2007).

Physical habitat structure was characterized by using NAWQA Program protocols (Fitzpatrick et al. 1998), generally after invertebrate sampling was completed.

Details on the processing and derivation of habitat metrics can be found in Giddings et al. (2009).

Invertebrate responses to urbanization were evaluated by relating assemblage structure and assemblage metrics to urban intensity. Nonmetric multidimensional scaling (NMDS) was used to derive the ordination axis sample scores after applying a 4th root transformation to the density data and using Bray-Curtis similarity for RTH samples and Jaccard similarity for QMH samples (Clarke and Gorley 2006). NMDS plots were examined for outliers, which were removed prior to analysis. Ordination sample scores were rescaled (Cuffney et al. 2005) to convert all ordination scores to positive values that were consistent with the response of the EPT richness metric to urbanization (i.e., decrease in value as urbanization increases) (Paul and Meyer 2001, Morse et al. 2003). Linear regression was used to determine the relation (slope) between assemblages (ordination sample scores) and urban intensity.

Assemblage metrics were correlated (Spearman rank correlation; SPSS 2007) with urban intensity to determine how strongly metrics were associated with urban intensity. Correlation analyses emphasized similarities among metropolitan areas by focusing on correlations that were statistically significant and indicative of strong correlation ($|\rho| \geq 0.65$) in at least three of the nine metropolitan areas.

Infrastructure, hydrology, water chemistry, habitat, and water temperature were correlated (Spearman rank correlation; SPSS 2007) with urban intensity (MA-NUII) and invertebrate responses (rescaled NMDS axis-1 sample scores) to identify environmental factors that may be important in characterizing and managing urbanization locally and at the national scale. Strong correlations were identified using the same criteria that identified strong correlations between NMDS sample scores and urban intensity ($|\rho| \geq 0.65$ in three or more metropolitan areas).

Results

The rates at which indicators of urbanization (landcover, census, and infrastructure) change in response to changes in population density differed among metropolitan areas (e.g. developed land, Figure 2). Consequently, the MA-NUII index was modified to form the national urban intensity index (NUII) that accounted for these regional differences in response

rates (Cuffney and Falcone 2008). The MA-NUII index is scaled to range from 0 to 100 in each metropolitan area (Figure 3A), whereas the NUII is scaled to range from 0 to 100 over all nine metropolitan areas (Figure 3B). Rescaling to account for regional differences among metropolitan areas showed that the maximum level of urbanization that occurred in the eastern United States was substantially less than in the central and western United States (Figure 3). This difference is thought to be associated with stream burial in the inner cities of the east (Elmore and Kaushal 2008) that effectively eliminated these streams from the studies.

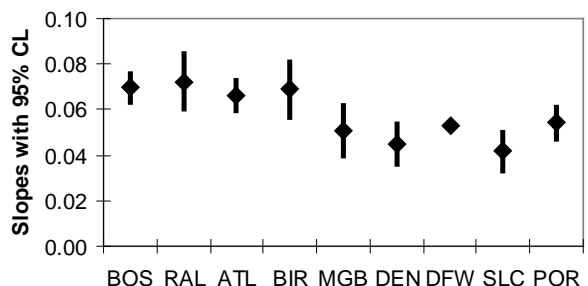

Figure 2. The rates at which the percentage of basin area in developed land change as population density changes differ among the nine metropolitan areas. [CL, confidence limit]

The biological responses to urbanization showed statistically significant responses between ordination site scores (NMDS axis 1) and MA-NUII in 6 of the 9 metropolitan areas for RTH and 8 of 9 for QMH samples. The metropolitan areas that did not show responses to urbanization for invertebrates (MGB, DEN, DFW) were those where urbanization progressed by the conversion of agricultural lands (row crop, pasture, and grazing lands). In these areas the effects of urbanization were masked by the effects of agriculture on invertebrate assemblages.

Invertebrate responses to urbanization were generally linear with no evidence for an initial threshold. That is, degradation of the invertebrate assemblages began as soon as the background landcover was disturbed (Figure 4). Proposed criteria for biological protection based on 5 and 10 percent impervious surface were not protective. For example, 10 percent impervious surface in Boston corresponded to an MA-NUII score of 33 and represented one-third of the change that occurred over the entire urban gradient (Figure 4).

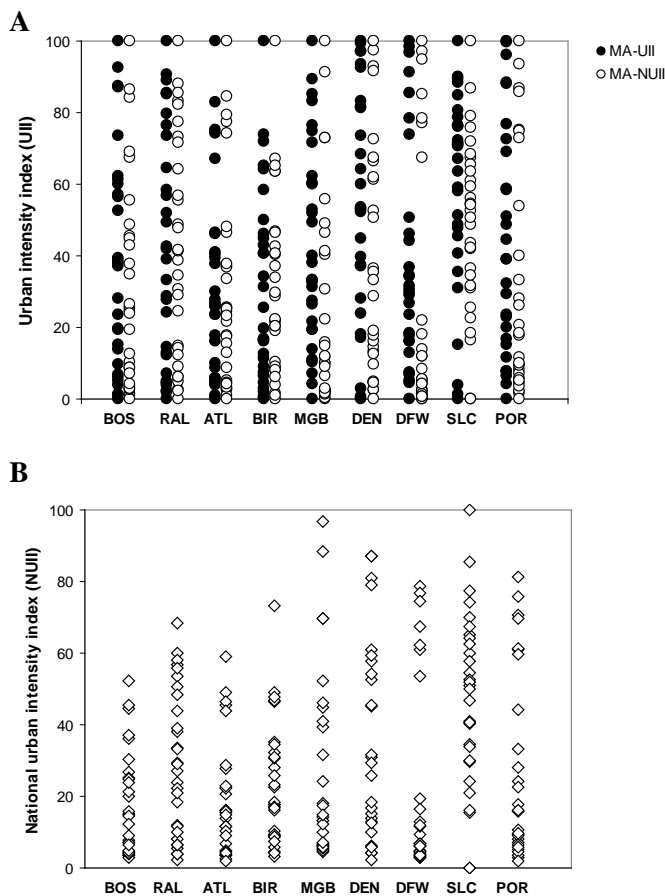

Figure 3. Distribution of sites in each metropolitan area based on the (A) MA-UUI and MA-NUUI indices or the (B) NUUI index.

The environmental variables that were most strongly correlated with invertebrate responses (NMDS axis 1 site scores) showed considerable variation among metropolitan areas (Table 1). Census, landcover, and infrastructure variables were associated with changes in invertebrate assemblages in 5 of the 9 metropolitan areas. Chemistry, hydrology, water temperature, and habitat were less frequently associated with changes in invertebrates. In part, this reflects the difficulty in measuring these highly variable parameters in an ecologically meaningful way.

The relations between invertebrate responses and environmental variables were more fully developed using multilevel hierarchical linear regression models (Gelman and Hill 2007). This type of regression model can incorporate predictor variables at multiple scales. We used the percentage of basin area in developed land as the site level predictor and antecedent agricultural landcover (mean row crop, pasture, and grazing land at

sites with MA-NUUI ≤ 10) and mean annual air temperature for each metropolitan area as regional predictors. The multilevel hierarchical linear regression model predicts the intercept (a) and slope (b) of the regression relating invertebrate responses to percentage of developed land ($y_{ij} = a_j + b_j X_{ij}$) on the basis of regional variables ($a_j = \alpha_{0j} + \beta_{0j} R_j$ and $b_j = \alpha_{1j} + \beta_{1j} R_j$). The mean tolerance value for invertebrates at a site (Cuffney 2003) was used as the invertebrate response variable, y , that varied by site (i) and region (j).

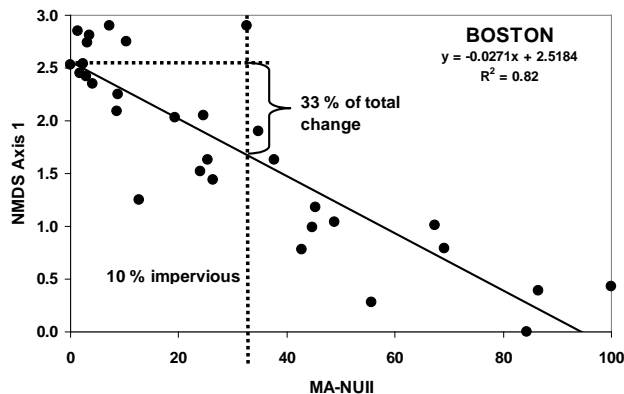

Figure 4. A criterion of 10 % impervious surface (equivalent to a MA-NUUI of 32.6) corresponds to a 33 % change in the invertebrate assemblage and is not protective.

Table 1. Environmental variables that are strongly correlated with changes in invertebrate assemblages. [Number of metropolitan areas with strong correlations are listed in parentheses. Pop., population; TEQ, toxicity equivalents]

Environmental variable	Environmental variable
Census	Chemistry
Pop. density (5)	Conductivity (3)
Housing density (5)	Sulfate (3)
% pop. in urban (5)	Pesticides detected (4)
Landcover	Toxicity: TEQ (4)
% developed (5)	Hydrology
% impervious (5)	Flashiness: rise/fall (2)
Infrastructure	Water temperature
Roads (5)	Mean summer (3)
	Habitat (1)

Multilevel regression showed that antecedent agriculture had a strong effect on the value of the slope and intercept that relates invertebrate tolerance to

percentage developed land (Figure 5). The higher average tolerance value of the intercept in metropolitan areas with high antecedent agriculture shows that high agriculture results in tolerant assemblages even in the absence of urbanization. The higher slopes associated with metropolitan areas with low antecedent agriculture indicates that these areas undergo more degradation as a result of urbanization than those areas that are already heavily affected by agriculture. These results indicate that the efforts to mitigate effects of urbanization in areas with high levels of antecedent agriculture must take into account the negative effects of the agriculture when determining the levels of recovery that can be achieved. These results also establish why statistically significant responses were not observed for MGB, DEN, and DFW, which have high levels of antecedent agriculture.

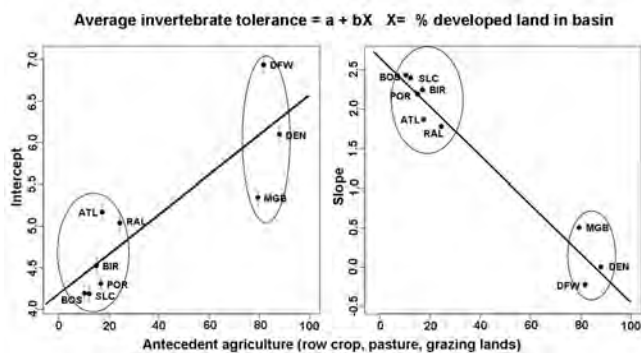

Figure 5. Multilevel hierarchical regression relating average invertebrate tolerance to percentage developed land using antecedent agriculture as a regional variable.

A cursory examination of Figure 5 shows that the 9 metropolitan areas group into high (≥ 70) and low (< 30) classes based on antecedent agriculture. Consequently, the effects of antecedent agriculture can be expressed as a categorical variable (high and low), and regional effects can be examined within each of these categories (Figure 6). This combined analysis shows both the effects of antecedent agriculture and average annual temperature on the response of invertebrates to changes in landcover.

The intercepts in Figure 6 indicate that in the absence of urbanization the average tolerance of invertebrates are higher (conditions are worse) in regions with high levels of antecedent agriculture than in regions with low levels. In addition, this figure shows that average tolerance is affected by temperature regardless of the degree of antecedent agriculture. This has significance for climate change models because it shows that rising

temperatures will result in degradation of invertebrate assemblages in both agricultural and non-agricultural regions as tolerant taxa are lost due to rising temperatures.

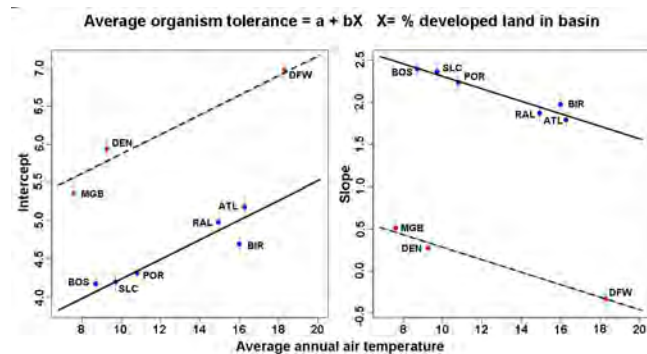

Figure 6. Multilevel hierarchical regression relating average invertebrate tolerance to percentage developed land using antecedent agriculture as a categorical variable regional variable and average annual air temperature as a continuous regional variable.

The slopes shown in Figure 6 indicate that the rates at which average invertebrate tolerance changes are affected by temperature in both agricultural and non-agricultural regions, though the rates of change are higher in the non-agricultural regions. Consequently, climate changes can be expected to affect non-agricultural areas to a greater extent than agricultural areas that are already degraded.

The distribution of regional antecedent agriculture shown in Figure 5 has implications for an understanding of national patterns in urban development. That is, is the gap in regional antecedent agriculture between 30 and 70 percent of basin area real or is it an artifact of the 9 metropolitan areas chosen for study? The NAWQA Program has data from 3 other metropolitan areas (Anchorage, AK; Chicago, IL; and Seattle, WA) that will be used to assess model performance; however, each of these areas falls into the existing categories of high (Chicago) and low (Anchorage and Seattle) agriculture. We are currently working toward compiling statistics on antecedent agriculture for the Nation to determine the representativeness of the 9 metropolitan areas.

Conclusions

The rates at which census, landcover, and infrastructure characteristics change relative to population density are not constant across the country, and the characterization

of urbanization should take this regional variability into account. Invertebrate responses are generally linear and did not display any threshold responses. The environmental variables associated with invertebrate responses varied regionally. Multilevel hierarchical regression models revealed that antecedent agriculture had a strong influence on invertebrate responses because of the degradation associated with agriculture. Multilevel modeling also showed a strong influence of temperature on the initial condition of invertebrate assemblages and the rates at which they respond to urbanization. This result has important implications for assessing the effects of climate change on invertebrate assemblages and water quality.

Acknowledgments

We gratefully acknowledge the many colleagues who have worked tirelessly to collect samples, analyze data, and write the reports that support this summary paper. We also thank the many property owners and municipalities for granting us permission to access and sample these streams. Without their generous support, none of this work would have been possible. We also thank Larry Brown and Jim Coles of the USGS for providing critical comments on previous versions of this paper.

References

- Booth, D.B., and C.J. Jackson. 1997. Urbanization of aquatic systems: Degradation thresholds, stormwater detention and the limits of mitigations. *Water Resources Bulletin* 33:1,077–1,090.
- Brenton, R.W., and T.L. Arnett. 1993. Methods of analysis by the U.S. Geological Survey National Water Quality Laboratory: Determination of dissolved organic carbon by UV-promoted persulfate oxidation and infrared spectrometry. U.S. Geological Survey Open-File Report 92-480.
- Brown, L.R., R.H. Gray, R.M. Hughes, and M.R. Meador. 2005. Introduction to Effects of Urbanization on Stream Ecosystems. In L.R. Brown, R.M. Hughes, R. Gray, and M.R. Meador, eds., *Effects of Urbanization on Stream Ecosystems*, pp. 1–8. American Fisheries Society, Symposium 47, Bethesda, MD.
- Bryant, W.B., S.L. Goodbred, T.L. Leiker, L. Inouye, and B.T. Thomas. 2007. Use of chemical analysis and assays of semipermeable membrane devices extracts to assess the response of bioavailable organic pollutants in streams to urbanization in six metropolitan areas of the United States. U.S. Geological Survey, Scientific Investigations Report 2007-5113.
- Clarke, K.R., and R.N. Gorley. 2006. *PRIMER (Plymouth Routines in Multivariate Ecological Research)*, ver. 6: User manual/tutorial. PRIMER-E, Ltd., Plymouth, UK.
- Coles, J.F., T.F. Cuffney, and G. McMahon. 2004. The effects of urbanization on the biological, physical, and chemical characteristics of coastal New England streams. U.S. Geological Survey, Professional Paper 1695.
- Cuffney, T.F. 2003. User's manual for the National Water-Quality Assessment Program Invertebrate Data Analysis System (IDAS) software, ver. 3. U.S. Geological Survey, Open-File Report 03-172.
- Cuffney, T.F., M.D. Bilger, and A.M. Haigler. 2007. Ambiguous taxa: Effects on the characterization and interpretation of invertebrate assemblages. *Journal of the North American Benthological Society* 26:286–307.
- Cuffney, T.F., and R.A. Brightbill. 2008. Methods for processing and summarizing time-series temperature data collected as a part of the National Water-Quality Assessment Program studies on the effects of urbanization on stream ecosystems. U.S. Geological Survey, Data Series 330.
- Cuffney, T.F., and J.F. Falcone. 2008. Derivation of nationally consistent indices representing urban intensity within and across nine metropolitan areas of the conterminous United States. U.S. Geological Survey, Scientific Investigations Report 2008-5095.
- Cuffney, T.F., M.E. Gurtz, and M.R. Meador. 1993. Methods for collecting benthic invertebrate samples as part of the National Water-Quality Assessment Program. U.S. Geological Survey, Open-File Report 93-406.
- Cuffney, T.F., H. Zappia, E.M.P. Giddings, and J.F. Coles. 2005. Effects of urbanization on benthic macroinvertebrate assemblages in contrasting environmental settings: Boston, Massachusetts; Birmingham, Alabama; and Salt Lake City, Utah. In

- L.R. Brown, R.M. Hughes, R. Gray, and M.R. Meador, eds., *Effects of Urbanization on Stream Ecosystems*, pp. 361–407. American Fisheries Society, Symposium 47, Bethesda, MD.
- Elmore, A.J., and S.S. Kaushal. 2008. Disappearing headwaters: Patterns of stream burial due to urbanization. *Frontiers in Ecology and the Environment* 6(6):308–312.
- Falcone, J.F., J. Stewart, S. Sobieszcyk, J. Dupree, G. McMahon, and G. Buell. 2007. A comparison of natural and urban characteristics and the development of urban intensity indices across six geographic settings. U.S. Geological Survey, Scientific Investigations Report 2007-5123.
- Fishman, M.J. 1993. Methods of analysis by the U.S. Geological Survey National Water-Quality Laboratory: Determination of inorganic and organic constituents in water and fluvial sediment. U.S. Geological Survey, Open File Report 93-125.
- Fishman, M.J., and L.C. Friedman. 1989. Methods for determination of inorganic substances in water and fluvial sediments. U.S. Geological Survey, Techniques of Water-Resources Investigations, Book 5, Chapter A1.
- Fitzpatrick, F.A., I.R. Waite, P.J. D'Arconte, M.R. Meador, M.A. Maupin, and M.E. Gurtz. 1998. Revised methods for characterizing stream habitat in the National Water-Quality Assessment Program. U.S. Geological Survey, Water-Resources Investigations Report 98-4052.
- Gelman, A., and J. Hill. 2007. *Data Analysis Using Regression and Multilevel/Hierarchical Models*. Cambridge University Press, New York.
- Giddings, E.M.P., A.H. Bell, K.M. Beaulieu, T.F. Cuffney, J.F. Coles, L.R. Brown, F.A. Fitzpatrick, J. Falcone, L.A. Sprague, W.L. Bryant, M.C. Peeper, C. Stephens, and G. McMahon. 2009. Selected physical, chemical, and biological data used to study urbanizing streams in nine metropolitan areas of the United States, 1999–2004. U.S. Geological Survey Data Series 423.
- Huryn, A.D., V.M.B. Huryn, C.J. Arbuckle, and L. Tsomides. 2002. Catchment land-use, macroinvertebrates and detritus processing in headwater streams: Taxonomic richness versus function. *Freshwater Biology* 47:401–415.
- Kennen, J.G. 1999. Relation of macroinvertebrate community impairment to catchment characteristics in New Jersey streams. *Journal of the American Water Resources Association* 36:939–955.
- Kennen, J.G., and M.A. Ayers. 2002. Relation of environmental characteristics to the composition of aquatic assemblages along a gradient of urban land use in New Jersey, 1996–98. U.S. Geological Survey, Water-Resources Investigations Report 02-4069.
- McMahon, G., and T.F. Cuffney. 2000. Quantifying urban intensity in drainage basins for assessing stream ecological conditions. *Journal of the American Water Resources Association* 36:1,247–1,261.
- Morley, S.A., and J.R. Karr. 2002. Assessing and restoring the health of urban streams in the Puget Sound basin. *Conservation Biology* 16:1,448–1,509.
- Morse, C.C., A.D. Huryn, and C. Cronan. 2003. Impervious surface area as a predictor of the effects of urbanization on stream insect communities in Maine, U.S.A. *Environmental Monitoring and Assessment* 89:95–127.
- Moulton, S.R., J.L. Carter, S.A. Grotheer, T.F. Cuffney, and T.M. Short. 2000. Methods for analysis by the U.S. Geological Survey National Water Quality Laboratory: Processing, taxonomy, and quality control of benthic macroinvertebrate samples. U.S. Geological Survey, Open-File Report 00-212.
- Moulton, S.R., II, J.G. Kennen, R.M. Goldstein, and J.A. Hambrook. 2002. Revised protocols for sampling algal, invertebrate and fish communities as part of the National Water-Quality Assessment Program. U.S. Geological Survey, Open-File Report 02-150.
- Munn, M.D., and R.J. Gilliom. 2001. Pesticide toxicity index for freshwater aquatic organisms. U.S. Geological Survey, Water-Resources Investigation Report 01-4077.
- Ourso, R.T., and S.A. Frenzel. 2003. Identification of linear and threshold responses in streams along a gradient of urbanization in Anchorage, Alaska. *Hydrobiologia* 501:117–131.

- Paul, M.J., and J.L. Meyer. 2001. Streams in the urban landscape. *Annual Review of Ecology and Systematics* 32:333–365.
- Roy, A.H., A.D. Rosemond, M.J. Paul, D.S. Leigh, and J.B. Wallace. 2003. Stream macroinvertebrate response to catchment urbanization (Georgia, U.S.A). *Freshwater Biology* 48:329–346.
- Shelton, L.R.. 1994. Field guide for collecting and processing stream-water samples for the National Water-Quality Assessment Program. U.S. Geological Survey, Open-File Report 94-455.
- Sprague, L.A., D.A. Harned, D.W. Hall, L.H. Nowell, N.J. Bauch, and K.D. Richards. 2007. Response of stream chemistry during base flow to gradients of urbanization in selected locations across the conterminous United States, 2002–04. U.S. Geological Survey, Scientific Investigations Report 2007–5083.
- SPSS. 2007. SYSTAT 12 Statistics I & II. SPSS, Inc., Chicago, IL.
- Tate, C.M., T.F. Cuffney, G. McMahon, E.M.P. Giddings, J.F. Coles, and H. Zappia. 2005. Use of an urban intensity index to assess urban effects on streams in three contrasting environmental settings. In L.R. Brown, R.M. Hughes, R. Gray, and M.R. Meador, eds., *Effects of Urbanization on Stream Ecosystems*, pp. 291–315. American Fisheries Society, Symposium 47, Bethesda, MD.
- U.S. Environmental Protection Agency. 1997. Determination of carbon and nitrogen in sediments and particulates of estuarine/coastal waters using elemental analysis, rev. 1.4. U.S. Environmental Protection Agency, Office of Research and Development, National Exposure Research Laboratory, Washington DC.
- U.S. Geological Survey. Various dated. National field manual for the collection of water-quality data. U.S. Geological Survey, Techniques of Water-Resources Investigations, Book 9, Chapters A1–A9, ver. 2. [online] URL: <http://pubs.water.usgs.gov/twri9a>. Accessed 18 June 2009.
- U.S. Geological Survey. 2003. National elevation data set. U.S. Geological Survey, Earth Resources Observation and Science Data Center, Sioux Falls, SD. [online] URL: <http://ned.usgs.gov/>.
- Walsh, C.J., A.K. Sharpe, P.F. Breen, and J.A. Sonneman. 2001. Effects of urbanization on streams of the Melbourne region, Victoria, Australia: I. Benthic macroinvertebrate communities: *Freshwater Biology* 46:535–551.
- Yoder, C.O., R.J. Miltner, and D.White. 1999. Assessing the status of aquatic life designated uses in urban and suburban watershed. In National Conference on Retrofit Opportunities for Water Resource Protection in Urban Environments, Proceedings, Chicago, IL, 9–12 February 1998, pp. 16–28.. U.S. Environmental Protection Agency, Office of Research and Development, EPA/625/R-99/002.
- Zaugg, S.D., M.W. Sandstrom, S.C. Smith, and K.M. Fehlberg. 1995. Methods of analysis by the U.S. Geological Survey National Water-Quality Laboratory: Determination of pesticides in water by C-18 solid-phase extraction and capillary-column gas chromatography/mass spectrometry with selected-ion monitoring. U.S. Geological Survey, Open-File Report 95-181.

Aquatic Ecosystems in Central Colorado Are Influenced by Mineral Forming Processes and Historical Mining

T.S. Schmidt, S.E. Church, W.H. Clements, K.A. Mitchell, D.L. Fey, R.B. Wanty, P.L. Verplanck, C.A. San Juan, T.L. Klein, E.H. DeWitt, B.W. Rockwell

Abstract

Stream water and sediment toxicity to aquatic insects were quantified from central Colorado catchments to distinguish the effect of geologic processes which result in high background metals concentrations from historical mining. Our sampling design targeted small catchments underlain by rocks of a single lithology, which allowed the development of biological and geochemical baselines without the complication of multiple rock types exposed in the catchment. By accounting for geologic sources of metals to the environment, we were able to distinguish between the environmental effects caused by mining and the weathering of different mineralized areas. Elevated metal concentrations in water and sediment were not restricted to mined catchments. Impairment of aquatic communities also occurred in unmined catchments influenced by

hydrothermal alteration. Hydrothermal alteration style, deposit type, and mining were important determinants of water and sediment quality and aquatic community structure. Weathering of unmined porphyry Cu-Mo occurrences resulted in water (median toxic unit (TU) = 108) and sediment quality (TU = 1.9) that exceeded concentrations thought to be safe for aquatic ecosystems (TU = 1). Metal-sensitive aquatic insects were virtually absent from streams draining catchments with porphyry Cu-Mo occurrences (1.1 individuals/0.1 m²). However, water and sediment quality (TU = 0.1, 0.5 water and sediment, respectively) and presence of metal-sensitive aquatic insects (204 individuals/0.1 m²) for unmined polymetallic vein occurrences were indistinguishable from that for unmined and unaltered streams (TU = 0.1, 0.5 water and sediment, respectively; 201 individuals/0.1 m²). In catchments with mined quartz-sericite-pyrite altered polymetallic vein deposits, water (TU = 8.4) and sediment quality (TU = 3.1) were degraded and more toxic to aquatic insects (36 individuals/0.1 m²) than water (TU = 0.4) and sediment quality (TU = 1.7) from mined propylitically altered polymetallic vein deposits. The sampling approach taken in this study distinguishes the effects of different mineral deposits on ecosystems and can be used to more accurately quantify the effect of mining on the environment.

Keywords: aquatic insects, ecotoxicology, toxic units, metals, geology, mining

Introduction

Lithology, geologic processes, and time control the geochemistry and morphology of the Earth's surface and thus profoundly affect ecosystems (Hynes 1975,

Schmidt is a Mendenhall post doctoral fellow and research ecologist, U.S. Geologic Survey, Mineral Resource Science Center, Denver, CO 80225; Fort Collins Science Center, Fort Collins, CO 80521. Church, Fey, Wanty, Verplanck, San Juan, DeWitt, Rockwell, and Klein are geologists, geochemists, and geospatial scientists, all with the U.S. Geological Survey, P.O Box 25046, MS 973, Denver, CO 80225. Clements and Mitchell ecotoxicologists, both with Colorado State University—Fish, Wildlife, and Conservation Biology Department, Fort Collins, CO 80521. Email: tschmidt@usgs.gov; schurch@usgs.gov; defy@usgs.gov; rwanty@usgs.gov; pverplanck@usgs.gov; csanjuan@usgs.gov; edewitt@usgs.gov; barnabyr@usgs.gov; tklein@usgs.gov; wille@cnr.colostate.edu; kmitchel@warnercnr.colostate.edu.

Vitousek et al. 1997, Cary et al. 2005). In combination with climate (i.e., precipitation and temperature) and vegetation (i.e., organic acids and anions), these processes determine the rate of mechanical and chemical weathering of bedrock, which influences the structure and function of terrestrial ecosystems (Drever 1994, Vitousek and Farmington 1997, Vitousek et al. 1997) and aquatic ecosystems (Wanty et al. 2002, Schmidt 2007).

In mineralized areas containing pyrite, degradation in water quality occurs when sulfide minerals are oxidized upon exposure to water and O₂ (Wanty et al. 2002), producing hydrogen ions. The acidic waters react with metal sulfides, forming metal hydroxides and locally high concentrations of dissolved metals, depending on the composition of rocks surrounding the mineral deposits (Plumlee et al. 1995). This natural redox cycle is enhanced by historical mining, which has exposed large volumes of unweathered, often pyritic rock with reactive surface areas enhanced in finely crushed rock.

Central Colorado was heavily mineralized during the Larimide orogeny by emplacement of plutons and associated sulfide mineral deposits of various types (Tweto and Simms 1963). Recent surveys of mountain streams in Colorado suggest that up to 25 percent are degraded by elevated metal concentrations (Clements et al. 2000). Generally, this degradation is assumed to result from the mineral extraction economy that began in central Colorado in 1859 (Chronic and Chronic 1972). It is largely unknown to what extent weathering has released metals that affect aquatic ecosystems in this region.

Hydrothermal alteration and ore deposit formation are complex enough that we must be precise about how we use terms describing these processes.

Hydrothermal alteration is a geologic process that results from rock/fluid interactions causing cation/anion exchanges that fundamentally change the geochemistry of host rocks (Robb 2005). The type and extent of hydrothermal alteration is controlled by five factors: temperature, pressure, host rock composition, fluid composition, and the volume of fluid/rock interactions (Reed 1997). Hydrothermal alteration is a part of the ore-forming process such that one will rarely find a mineral deposit that has not been influenced by hydrothermal fluids (Robb 2005).

There is a continuum of hydrothermal alteration styles ranging from propylitic to quartz-sericite-pyrite alteration. Propylitic alteration results from low temperature fluids/rock interactions at low pore water/rock volumes and forms epidote, chlorite, and other minerals with acid neutralizing capacity. This is the most widespread form of alteration in the study area. Quartz-sericite-pyrite alteration occurs under higher temperature and pressure and transforms feldspars into other minerals such as quartz, sericite, and pyrite, which is the major acid generating sulfide mineral.

A **mineral deposit** is a mineral occurrence of sufficient size and concentration and is accessible such that under favorable circumstances it would be considered to have economic potential (Cox and Singer 1986). An **ore deposit** is a mineral deposit which has been tested and is known to be of sufficient size, concentration, and accessibility, and is deemed beneficial for economic reasons to exploit. The term **mined** is reserved here for areas that were exploited such that publically available data indicated that a commodity from the mine site was produced. As a result, there are many catchments where ore-forming processes have elevated concentrations of metals in catchment rocks, which likely influence water and sediment quality despite prior mining (Tooker 1963, Tweto 1968, Wanty et al. 2002, Bove et al. 2007, Mast et al. 2007).

The expected water quality due to weathering of specific minerals associated with these hydrothermal alteration and deposit types have implications for the understanding of the changes in metal toxicity across the landscape. The bioavailability of a dissolved free-ion metal is affected by a suite of constituents (e.g., HCO₃⁻, CO₃²⁻, Cl⁻, Ca²⁺, Mg²⁺) found in surface water (Meyer 2002). By applying geoenvironmental models (Cox and Singer 1986) descriptive of the distribution of minerals that affect water quality and toxicity of metals, we can improve our ability to understand the effects of mining on aquatic ecosystems.

We evaluate the extent to which mining exacerbates the influence of ore-forming processes on the toxicity of metals to aquatic insect communities in streams of central Colorado. Two hypotheses are tested: (1) that elevated metals in water and sediment that may impair aquatic insect communities are restricted to

mined catchments (a presumption made in many ecological risk assessments of historical and abandoned mines), and (2) that ore-forming processes influence the effect of mining on water and sediment toxicity to aquatic insect communities. To test the first hypothesis, comparisons are made between catchments which were unmined and unaltered (referred to as reference), unmined and influenced by ore-forming processes identified as hydrothermal alteration (referred to as background), and mined catchments. To test the second hypothesis, it was necessary to reclassify our catchments (Church et al., this volume). Reference catchments were split into two mineral occurrence types: polymetallic vein (referred to as deposit type A) and porphyry Cu-Mo (copper-molybdenum) occurrences (deposit type B). Mined deposit type A catchments were broken down by the style of hydrothermal alteration associated with their formation: propylitic or quartz-sericite-pyrite alteration.

Methods

Study design

Stream water and sediment were collected from 198 catchments during base-flow conditions during the summers (July through August) of 2003–2007 (Figure 1) (Church et al., in press). In a subset of these catchments, aquatic insect communities were collected upstream from the site where water and sediment samples were collected (Church et al., in press). Aquatic insects were collected either simultaneous with or within a few days immediately following the collection of stream water and sediment. Digital elevation models (DEM, 30-m resolution) were used to define catchment boundaries using geographic information systems (ArcGIS 9.2). Small catchments (1st- and 2nd-order streams) predominantly underlain by a single lithology (rocks of similar geochemistry and mode of formation) were sampled. Catchments were characterized as unaltered, influenced by different styles of hydrothermal alteration, or historically mined (Figure 1). Field parameters, geochemical results, and quality assurance/quality control (QA/QC) data are reported in Church et al. (in press).

Hydrothermal alteration was mapped (Figure 1) and characterized across the study area primarily using mineral maps derived from analysis of advanced spaceborne thermal emission and reflection radiometer (ASTER) remote-sensing data. Such ASTER maps were supplemented and verified by published hydrothermal alteration data at local scales (generally from dissertations and wilderness studies) and more detailed mineral maps generated from airborne visible/infrared imaging spectrometer (AVIRIS) data. Hydrothermal alteration identified using the ASTER data was classified as advanced argillic, argillic \pm ferric iron, quartz-pyrite-sericite (QSP), and propylitic on the basis of spectrally identified mineral assemblages. For example, the QSP alteration type was characterized by the occurrence of ferric iron + sericite \pm kaolinite. Several minerals that are associated with alteration may also occur in unaltered sedimentary and metamorphic rocks. Hydrothermally altered areas were differentiated from unaltered areas by applying a 3-km buffer around intrusions and by excluding specific lithochemical units (Church et al. 2008) that contain abundant muscovite (e.g., shale and metapelite) and (or) carbonate minerals (limestone and dolomite). This process allowed for the inclusion of areas which were hydrothermally altered and the exclusion of areas that have mineral assemblages that formed under other geologic processes. The mapping of alteration using remote sensing data is possible only where the ground is not covered by vegetation, thus adding a degree of uncertainty to this level of catchment classification. It is unknown how much of the area is hydrothermally altered but so obscured by vegetation that we could not map it. Some catchments that have no evidence of historical mining activity are, nevertheless, hydrothermally altered.

Databases from the State of Colorado (M.A. Sares, 2008, U.S. Forest Service Abandoned Mine Land Inventory, Colorado, Colorado Geological Survey, unpub. report) and the Federal Government (Mineral Resource Data System, U.S. Geological Survey) were used to determine disturbance by mining (Figure 1). Catchments were characterized as mined if publically available data indicated that a commodity from the mine site was produced. For all

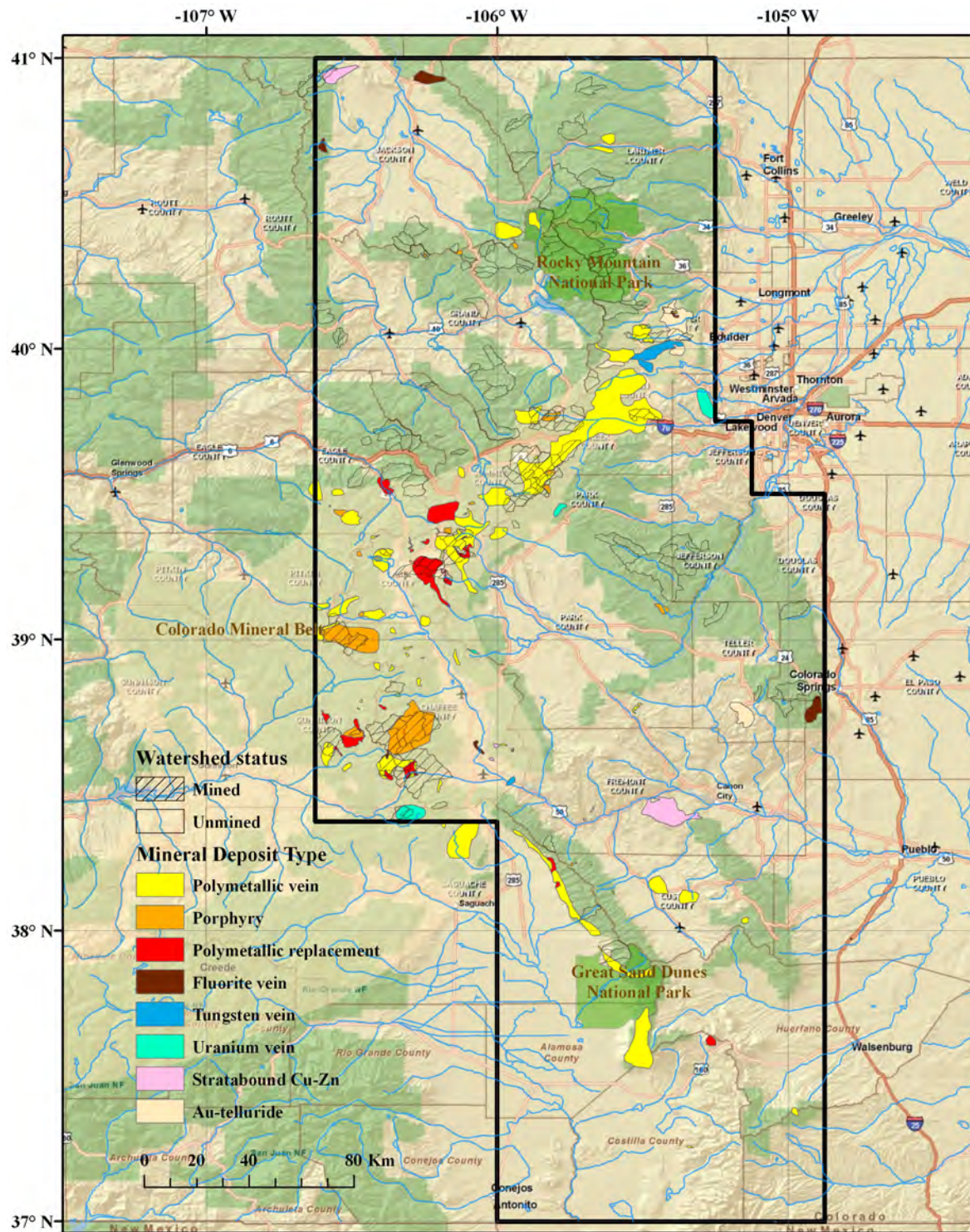

Figure 1. Map of central Colorado study area showing sampled catchments. In this figure, catchments are classified on the basis of disturbance by historical mining and deposit type.

other disturbances (such as adits, shafts, and prospect pits), for the deposit types considered here, we found few cases in which these disturbances were observed to increase sulfide mineral weathering to a degree we could distinguish from reference. As a result we lumped catchments influenced by adits, shafts, and prospect pits into the unmined group.

Geochemical analysis

Filtered (0.45 μm) and unfiltered water samples were analyzed using both inductively coupled plasma–atomic emission spectrometry (ICP-AES) and inductively coupled plasma–mass spectrometry (ICP-MS). Sediment samples were prepared using total digestion and EPA 3050B leach procedures. Analyses were done using both ICP-AES and ICP-MS. Detailed analytical methods; QA/QC data on duplicates, replicates, and standard reference materials; and analytical results are described in Church et al. (in press).

Previous work has shown that sediment geochemistry is dominated by colloids, which vary in proportion seasonally and with storm events (Fey et al. 2002, Church et al. 2007a). Thus, each sample was treated as a separate observation to determine a range of element concentrations from these disturbed catchments. Both filtered and unfiltered water and fine sediment samples (sieved to 177 μm) collected from 198 catchments over a 4-yr period (2003–2007) constitute the data set discussed in this paper. No duplicate samples were included in this evaluation.

Benthic macroinvertebrate sampling

Five replicate benthic samples ($n = 5$) were collected using a 0.1- m^2 Hess sampler (minus 350- μm mesh net) from shallow riffle areas (<0.5 m). Representative sample localities were selected on the basis of the following criteria: location was a riffle or run habitat unit, depth was 0.10–0.25 (m), and substrate was representative of the stream reach. Overlying substrate was scrubbed of all algae and diatoms and inorganic debris was removed. Underlying substrate was disturbed to a depth of approximately 10 cm and the remaining material was sieved using a 350- μm mesh sieve. All organisms

retained were preserved in 80 percent ethanol in the field.

In the laboratory, samples were processed to remove debris and sub-sampled until 300 organisms (± 10 percent) were removed from the sample following methods described by Moulton et al. (2000). Invertebrates were identified to the lowest practical taxonomic level (genus or species for most taxa; subfamily for chironomids) (Merritt and Cummings 1996, Ward et al. 2002). Means of the five replicate benthic samples were used to calculate the density (number of individuals per 0.1 m^2) of taxa known to be sensitive to metals (i.e., mayflies, stoneflies + caddisflies) (Clements et al. 2000).

Determination of toxic units

Streams are often impaired by a mixture of trace metals at chronic concentrations that act additively to cause toxicity to aquatic organisms (Clements et al. 2000, Playle 2004). Toxic units (TUs) are the ratio of measured metal concentration for a given site (water or sediment) normalized by a benchmark protective of freshwater organisms. Toxicity due to multiple metals is accounted for by summing the toxic unit value for each metal observed at a site as follows:

$$\Sigma TU = \sum_i \frac{m_i}{c_i}$$

where m_i is the metal concentration and c_i is a benchmark value for the i^{th} metal (Table 1). Because cadmium, copper, and zinc (Cd, Cu, and Zn) are the primary metals of concern in the central Colorado Rocky Mountain region, all toxic units reported are the sum of all three metals.

The benchmark values for metals in water are derived from the U.S. Environmental Protection Agency Criterion Continuous Concentration (CCC) (National Academies of Sciences and Engineering 1973). The CCC is an estimate of the highest concentration of a material in surface water to which an aquatic community can be exposed indefinitely without resulting in an unacceptable effect.

Table 1. List of benchmarks used to derive toxic units (TU) for water and sediment.

	Water (nmol/g of gill tissue wet weight) ¹	Sediment (mg/kg dry weight) ²
Cd	0.341	4.98
Cu	0.106	49
Zn	1.356	459

¹Major cations, anions, and organic ligands influence the toxicity of aqueous metals to aquatic organisms, and the Biotic Ligand Model is capable of predicating toxicity to aquatic organisms (HydroQual 2007). Benchmarks for water calculated using the Biotic Ligand Model to determine the amount of metal available to bind at the biotic ligand at U.S. EPA continuous chronic criteria metal concentrations using methods described in Schmidt (2007).

²Benchmarks for sediment are the probable effect concentration consensus-based sediment quality guideline derived from MacDonald et al. (2000).

However, these are values applied to water regardless of other characteristics of the water body. Dissolved organic carbon, major cations, anions, pH, and alkalinity are known to modify the toxicity of dissolved metals to aquatic organisms (Tipping 1994, Santore and Driscoll 1995). The Biotic Ligand Model is a computer model that, for a single metal, predicts acute toxicity to aquatic organisms while accounting for the influences of water quality on metal toxicity to aquatic organisms (HydroQual 2007). Schmidt (2007) developed a method which modifies the Biotic Ligand Model to derive m_i and c_i for water, while accounting for difference in water quality between sample locations and predicting the toxicity of multiple metals to aquatic insect communities. Here we used the method developed by Schmidt to derive the benchmark values for metals in water found in Table 1.

The benchmark values for sediment were derived from the consensus-based sediment quality guidelines Probable effect concentrations (PECs) (CBSQG; MacDonald et al. 2000). The PECs are those metal concentrations above which adverse effects on aquatic ecosystems are expected to occur more often than not. Because much less is known as to how sediment quality influences the availability of metals to aquatic organisms, no modifying factors are accounted for in determining the toxicity of sediment metal to aquatic organisms. Sediment benchmark values are in Table 1.

Data analysis

For simplicity and ease of interpretation, all data are presented as box-plots. The sample population is depicted as boxes where the tops and bottoms

represent the 75th and 25th percentiles, respectively, and the dividing line is the 50th percentile or the median value. The whiskers extend to the 5th percentile (bottom) and 95th percentile (top) of the data distribution. The dots report the largest outlier. Differences in samples are easily determined by comparing locations (medians) and data distributions between different sample populations.

Results

All water and sediment samples collected from reference catchments were found to be well below the toxic threshold of 1 TU (median TU = 0.1 for water and 0.5 for sediment; Figure 2). In contrast, water and sediment from background catchments often exceeded TU = 1 with median values for water (0.2) and for sediment (0.9). Fourteen of the 39 water samples (36 percent of the samples) in the background category exceeded a TU = 1, whereas 19 of 39 sediment samples (48 percent) exceeded this threshold. Most water (median TU = 1.4) and sediment (median TU = 2.3) samples from mined catchments exceed the toxic threshold with 51 percent of the water and 68 percent of the sediment samples exceeding a TU = 1.

Responses of metal-sensitive aquatic insects mirrored the finding that background catchments and mined catchments can produce both water and sediment that are toxic to aquatic insect communities (Figure 2). Reference catchments produced a community of metal-sensitive aquatic insects with a median value of 201 individuals/0.1 m², as

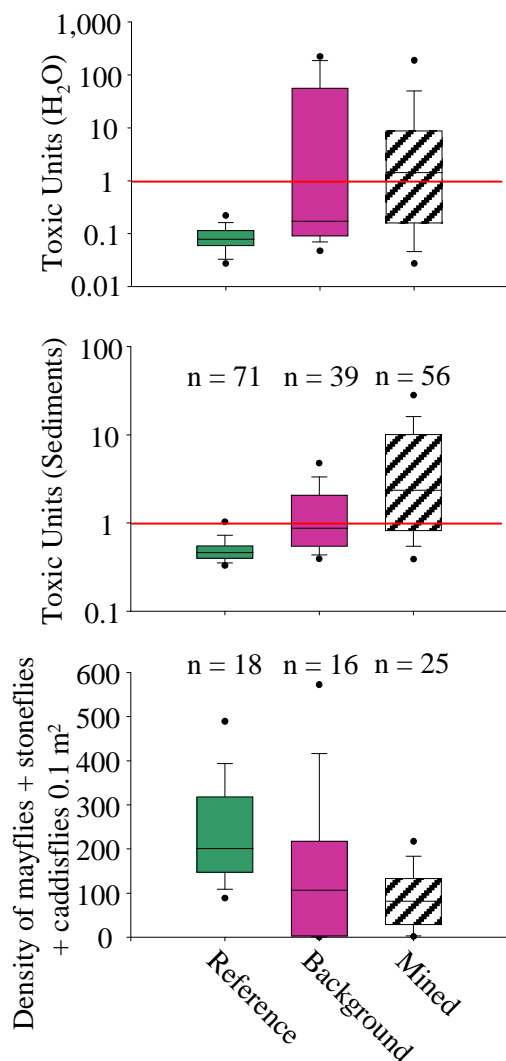

Figure 2. Effect of hydrothermal alteration and mining on water and sediment toxicity to metal sensitive aquatic insect communities. Sample size for water and sediment are identical. Solid colored box plots are unmined. Striped box plots are mined. Green colored (reference) box plots are data from unmined and not hydrothermally altered catchments. Purple colored (background) box plots are data from hydrothermally altered but unmined catchments. Green (reference) box plot is found in Figure 3, while the purple (background) box plot is split into two groups in Figure 3, based on deposit type.

compared to altered and mined catchments (107 individuals/0.1 m²) with 63 percent of the samples falling below the median value for referenced catchments. Mined catchments were found to have a median value of 90 individuals/0.1 m², with 95 percent of the samples falling below the reference median.

The effect of mining, hydrothermal alteration, and mineral deposit type on water and sediment toxicity to aquatic insects is depicted in Figure 3. The effect of hydrothermal alteration (propylitic vs QSP) on background type A deposits was indistinguishable, so both styles of hydrothermal alteration were lumped together to compose this category. The median values for water (0.1 TU) and sediment (0.52 TU) from background type A deposits were not different from reference. In contrast, catchments containing background type B deposits (all of which are QSP altered) produced toxic water (median TU = 108) and sediment (median TU = 1.9). All the water sampled from background type B deposits exceeded the toxic threshold of 1, whereas 2 of the 14 sediment samples did not.

The effect of mining and hydrothermal alteration was distinguishable for type A deposits (Figure 3). Water from streams draining mined propylitically altered type A deposits were less toxic (median water = 0.4 TU, sediment = 1.7 TU) than those from mined QSP altered type A deposits (water = 8.4 TU, sediment = 3.1 TU). Only 1 water sample from the mined QSP altered type A deposits was found to be less than TU = 1. Only 1 sediment sample from a mined and propylitically altered type A deposit was found to be less than the median background value for type A deposits.

Metal-sensitive aquatic insect communities from background type A deposits (median 204 individuals/0.1m²) were indistinguishable from those from reference sites. However, background type B deposits were so toxic that aquatic insects were nearly absent from these streams (median value of only 1.1 individuals/0.1 m²). Mining in catchments containing type A deposits resulted in lower densities of metal-sensitive taxa, but the effect was also dependent on the type of hydrothermal alteration present in the catchment. Mined QSP altered type A deposits only averaged 36 individuals/0.1 m², as compared to mined propylitically altered type A deposits, which had an average population density of 128 individuals/0.1 m².

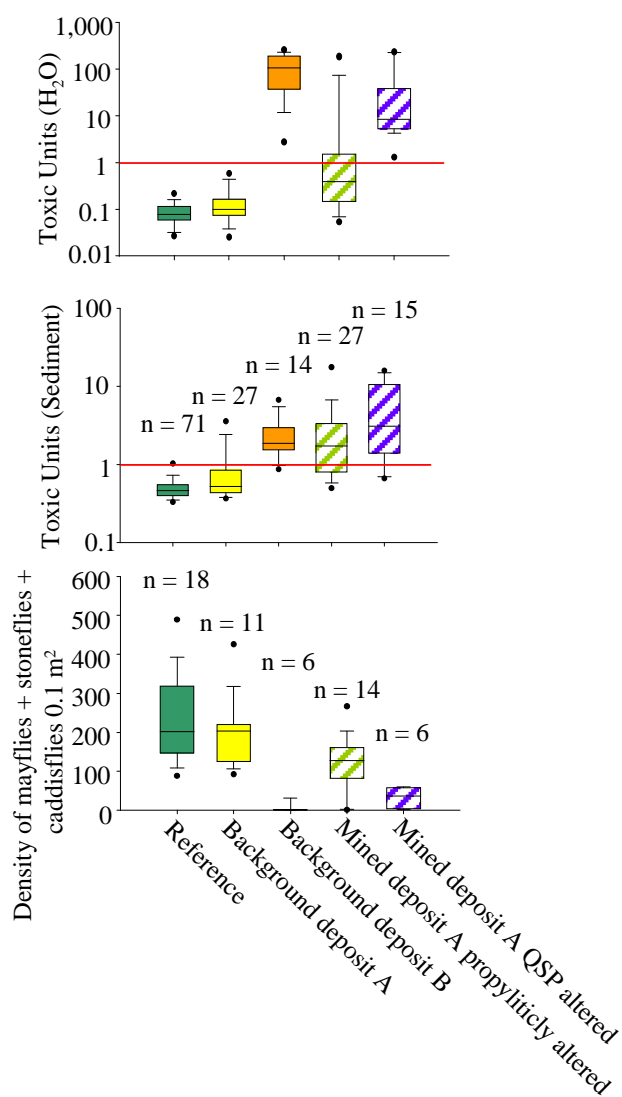

Figure 3. Effects of hydrothermal alteration (background sites), mining, and deposit type (A or B) on water and sediment toxicity to metal sensitive aquatic insect communities. Solid color box plots are unmined, and striped box plots are mined. Deposit A—polymetallic vein occurrences and deposits. Deposit B—porphyry Cu-Mo occurrences and deposits. QSP—quartz-sericite-pyrite.

Conclusions

We evaluated the extent to which mining versus ore-forming processes influenced the toxicity of water and sediment to metal sensitive aquatic insects. We found that elevated metals in water and sediment are not restricted to mined catchments. Impairment of aquatic communities also occurred in catchments that were unmined but had rocks that were

hydrothermally altered (background). The effect of mining on the toxicity of water and sediment is dependent on the style of hydrothermal alteration. Some streams draining catchments influenced by ore-forming processes likely never supported a robust aquatic community (e.g., Church et al. 2007b).

Historically, ecological risk assessments of abandoned mine lands have presumed that the presence of historical mining in a catchment caused elevated concentrations of metals in water and sediment that impaired aquatic communities. We demonstrated that this presumption in many cases is incorrect. Hydrothermally altered rock also causes elevated concentrations of metals in water and sediment that impaired aquatic communities prior to or in the absence of mining. Ecological communities in these catchments are impaired by metals released during weathering of the hydrothermally altered rock. Because historical mines are located in catchments that have been hydrothermally altered, not all the elevated metal concentrations in water and sediment from streams draining mined catchments can be attributed to increased weathering of mineral sulfides extracted during the mining process. However, mining was found to increase the toxicity of water and sediment to aquatic insects from catchments influenced by ore-forming processes.

The effect of hydrothermal alteration on the toxicity of water and sediment is not the same for all deposit types. Water and sediment from catchments that have background type A deposits were indistinguishable from reference catchments, suggesting no significant release of metals by weathering of mineral sulfides emplaced through the alteration process. In contrast, water and sediment from catchments containing background type B deposits were toxic, so much so that aquatic insects are essentially absent from these catchments. As a result, hydrothermal alteration and mineral deposit type must be considered in the evaluation of background sites when conducting environmental assessments of mined sites.

The influence of mining on the same deposit type is dependent on the style of hydrothermal alteration. Mining of propylitically altered type A deposits resulted in elevated water and sediment toxicity and a modest reduction of metal-sensitive aquatic insects as compared to reference sites. However, mining of a QSP type A deposits resulted in an 80 percent

reduction of the metal-sensitive aquatic insects. Previous assessments would not have distinguished these differences. Had we compared the median number of metal-sensitive aquatic insects found at reference catchments (201 individuals/0.1 m²) to that observed at mined sites (90 individuals/0.1 m²), we would estimate that mining had caused a 55 percent decrease in the aquatic insect community. However, mined propylitically altered type A deposits were found to only decrease metal-sensitive aquatic insects by 36 percent. An even greater overestimation of the effect of mining on aquatic communities may occur if comparisons between reference sites and type B deposits are made without considering the fact that background type B deposits are so toxic that they nearly exclude aquatic insects.

Not quantifying the amount of weathered metals in streams from ore-forming processes may result in the overestimation of the number of streams impaired by historical mining. Our study determined that less than 5 percent of the study area is influenced by hydrothermally altered mineral occurrences and deposits (Church et al., this volume). As a result, it is likely that much of the streams thought to be impaired by metals are in fact influenced by drainage from hydrothermally altered rocks. A better understanding of the spatial distribution and ecological effects of mineral deposits in Colorado and the United States would greatly increase our ability to prioritize remediation of abandoned mines. Through the application of the principles learned here, the likelihood of successful mined land restoration can be greatly improved.

References

Bove, D.J., M.A. Mast, J.B. Dalton, and W.G. Wright. 2007. Major styles of mineralization and hydrothermal alteration and related solid- and aqueous-phase geochemical signatures. In S.E. Church, Paul von Guerard, and S.E. Finger, eds., *Integrated Investigations of Environmental Effects of Historical Mining in the Animas River Watershed*, San Juan County, Colorado, pp. 161–230. U.S. Geological Survey, Professional Paper 1651. [online] URL: <http://pubs.usgs.gov/pp/1651/>.

Cary, A.E., W.B. Lyons, and J.S. Owen. 2005. Significance of landscape age, uplift, and weathering rates to ecosystem development. *Aquatic Geochemistry* 11:215–239.

Chronic, J., and H. Chronic. 1972. *Prairie Peak and Plateau: A guide to the geology of Colorado*. Colorado Geological Survey, Bulletin 32.

Church, S.E., D.L. Fey, and D.M. Unruh. 2007a. Trace elements and lead isotopes in modern streambed and terrace sediment: Determination of current and premining geochemical baselines. In S.E. Church, Paul von Guerard, and S.E. Finger, eds., *Integrated Investigations of Environmental Effects of Historical Mining in the Animas River Watershed*, San Juan County, Colorado, pp. 571–642. U.S. Geological Survey, Professional Paper 1651. [online] URL: <http://pubs.usgs.gov/pp/1651/>.

Church, S.E., Paul von Guerard, and S.E. Finger, eds. 2007b. *Integrated investigations of environmental effects of historical mining in the Animas River watershed*, San Juan County, Colorado. U.S. Geological Survey, Professional Paper 1651. [online] URL: <http://pubs.usgs.gov/pp/1651/>.

Church, S.E., C.A. San Juan, E.H. DeWitt, T.L. Klein, R.B. Wanty, T.S. Schmidt, P.L. Verplanck, D.L. Fey, and L. McEachron. In press. Sample design, water, sediment, and benthic macroinvertebrate sampling strategy, and geologic data used for the regional environmental assessment of central Colorado. U.S. Geological Survey, Digital Data Series.

Clements, W.H., D.M. Carlisle, J.M. Lazorchak, and P.C. Johnson. 2000. Heavy metals structure benthic communities in Colorado mountain streams. *Ecological Applications* 10:626–638.

Cox, D.P., and D.A. Singer, eds. 1986. *Mineral deposit models*. U.S. Geological Survey, Bulletin 1693. [online] URL: <http://pubs.usgs.gov/bul/b1693/html/titlpage.htm>.

Di Toro, D.M., H.E. Allen, H.L. Bergman, J.S. Meyer, P.R. Paquin, and R.C. Santore. 2001. Biotic ligand model of the acute toxicity of metals: 1. Technical basis. *Environmental Toxicology and Chemistry* 20:2,383–2,396.

Drever, J.I. 1994. The effect of land plants on weathering rates of silicate minerals. *Geochimica et Cosmochimica Acta* 58(10):2,325–2,332.

- Fey, D.L., L. Wirt, J.M Besser, and W.G. Wright. 2002. Water quality and aquatic toxicity data of 2002 spring thaw conditions in the upper Animas River watershed, Silverton, Colorado. U.S. Geological Survey, Open-File Report 02-488.
- HydroQual. 2007. Biotic ligand model Windows interface user's guide and reference manual, ver. 2.2.3. HydroQual, Mahwah, NJ.
- Hynes, H.B.N. 1975. The stream and its valley: Verhandlungern Internationale Vereinigung Limnologie. *Limnologie* 19:1–15.
- MacDonald, D.D., C.G. Ingersoll, and T.A. Berger. 2000. Development and evaluation of consensus-based sediment quality guidelines for freshwater ecosystems. *Archives of Environmental Contamination and Toxicology* 39:20–31.
- Mast, M.A., P.L. Verplanck, W.G. Wright, and D.J. Bove. 2007. Characterization of background water quality. In S.E. Church, Paul von Guerard, and S.E. Finger, eds., *Integrated Investigations of Environmental Effects of Historical Mining in the Animas River Watershed, San Juan County, Colorado*, pp. 347–386. U.S. Geological Survey, Professional Paper 1651. [online] URL: <http://pubs.usgs.gov/pp/1651/>.
- Merritt, R.W., and K.W. Cummings. 1996. *An Introduction to the Aquatic Insects of North America* (3rd ed.). Kendall and Hunt Publishing Company, Dubuque, IA.
- Meyer, J.S. 2002. The utility of the terms "bioavailability" and "bioavailable fraction" for metals. *Marine Environmental Research* 53:417–423.
- Moulton, S.R., II, J.L. Carter, S.A. Grotheer, T.F. Cuffney, and T.M. Short. 2000. Methods of analysis by the U.S. Geological Survey national water quality laboratory: Processing, taxonomy, and quality control of benthic macroinvertebrate samples. U.S. Geological Survey, Open-File Report 00-212.
- National Academies of Sciences and Engineering. 1973. *Water quality criteria, 1972*. National Academy of Sciences and the National Academy of Engineering, for the U.S. Environmental Protection Agency, EPA-R3-73-033.
- Playle, R.C. 2004. Using multiple metal-gill binding models and the toxic unit concept to help reconcile multiple-metal toxicity results. *Aquatic Toxicology* 67:359–370.
- Plumlee, G.S., R.K. Streufert, K.S. Smith, S.M. Smith, A.R. Wallace, M.I. Toth, J.T. Nash, R.A. Robinson, W.H. Ficklin, and G.K. Lee. 1995. Map showing potential metal-mine drainage hazards in Colorado, based on mineral-deposit geology, ver. 1.0. U.S. Geological Survey, Open-File Report 95-26. [online] URL: <http://pubs.usgs.gov/of/1995/ofr-95-26/>.
- Reed, M.H. 1997. Hydrothermal Alteration and Its Relationship to Ore Fluid Composition. In H.L. Barnes, ed., *Geochemistry of Hydrothermal Ore Deposits*, pp. 303–366. John Wiley and Sons, New York.
- Robb, L. 2005. *Introduction to Ore-Forming Processes*. Blackwell Publishing, Malden, MA.
- Santore, R.C., and C.T. Driscoll. 1995. The CHES Model for Calculating Chemical Equilibria in Soils and Solutions. In R. Loeppert, A.P. Schwab, and S. Goldberg, eds., *Chemical Equilibrium and Reaction Models*, pp. 357–375. Soil Science Society of America Special Publication 42, American Society of Agronomy, Madison, WI.
- Schmidt, T.S. 2007. *Landscape Ecotoxicology: Linking Catchment Scale Geology to Trace-Metal Bioavailability and Benthic Macroinvertebrate Population and Community Responses*. Colorado State University, Department of Fish, Wildlife, and Conservation Biology. Ph.D. dissertation. Fort Collins, CO. 182 p.
- Sokal, R.R., and F.J. Rohlf. 2003. *Biometry* (3rd ed.). W.H. Freeman and Company, New York.
- Tipping, E. 1994. WHAM: A chemical equilibrium model and computer code for waters, sediments, and soils incorporating a discrete site/electrostatic model of ion-binding by humic substances. *Computers Geosciences* 20:973–1023.
- Tooker, E.W. 1963. Altered wallrocks in the central part of the Front Range mineral belt, Gilpin and

Clear Creek Counties, Colorado. U.S. Geological Survey, Professional Paper 439.

Tweto, O. 1968. Geologic Setting and Interrelationships of Mineral Deposits in the Mountain Province of Colorado and South-Central Wyoming. In J.D. Ridge, ed., *Ore Deposits of the United States 1933/1967*, pp. 551–588. The American Institute of Mining, Metallurgical, and Petroleum Engineers, New York.

Tweto, O., and P.K. Simms. 1963. Precambrian ancestry of the Colorado mineral belt. *Geological Society of America Bulletin* 74:991–1,014.

Vitousek, P.M., O.A. Chadwick, T.E. Crews, J.H. Fownes, D.M. Hendricks, and D. Herbert. 1997. Soil and ecosystem development across the Hawaiian Islands. *Geologic Society of America Today* 7:1–8.
Vitousek, P.M., and H. Farrington. 1997. Nutrient limitation and soil development: Experimental test of a biogeochemical theory. *Biogeochemistry* 37:63–75.

Wanty, R.B., B.R. Berger, G.S. Plumlee, and T.V.V. King. 2002. Geoenvironmental Models. In A.G. Fabbri, G. Gaal, and R.B. McCammon, eds., *Deposit and Geoenvironmental Models for Resource Exploitation and Environmental Security*, pp. 3–42. NATO Science Series 2: Environmental Security, v. 80. Springer, Boston, MA.

Ward, J.V., B.C. Kondratieff, and R. Zuellig. 2002. *An Illustrated Guide to the Mountain Stream Insects of Colorado* (2nd ed.). University of Colorado Press, Niwot, CO.

Timber Harvest and Turbidity in North Coastal California Watersheds

Randy D. Klein

Abstract

Turbidity regimes vary dramatically among small streams in north coastal California. In an analysis of turbidity data from 27 small streams in the region, turbidity at the 10-percent exceedence level ranged from 3 to 116 formazin nephelometric units (FNU) for the 2005 wet season, translating to 1.7 to 65 days above an oft-cited biological threshold of 25 FNU. Watersheds draining to the streams spanned disturbance categories from zero (pristine redwood forest) to intense commercial timber harvest. Grouping the sites by average annual timber harvest rate showed that the zero harvest (background) group averaged 13 FNU at the 10-percent exceedence level, while the low harvest group averaged 20 FNU and the high harvest group averaged 61 FNU, 58 percent and 369 percent, respectively—well above the “20 percent above background” regulatory limit for northern California streams.

Regression analyses of turbidity on watershed natural physiographic characteristics and land use histories (timber harvest and roads) showed the rate of recent timber harvest (average annual percent of watershed area) explained the greatest amount of variability in 10-percent turbidity exceedence. Drainage area was also significant but was secondary to harvest rate. None of the other watershed variables was found to improve the regression models. Despite much improved best management practices, contemporary timber harvest can trigger serious cumulative watershed effects when too much of a watershed is harvested over too short a time period.

Klein is a hydrologist, Redwood National and State Parks, Arcata, CA 95521. Email: randy_klein@nps.gov.

Keywords: turbidity, timber harvest, cumulative watershed effects

Introduction

It is widely acknowledged that historically intense timber harvest increased erosion and sediment delivery rates to extreme levels in the 1950s through the 1970s across the north coast of California (see Nolan and Janda 1995). Residual water quality effects from historical harvest certainly continue today to some degree. What is less certain, and more relevant to present-day management, is the extent to which contemporary timber harvest contributes to erosion, sediment delivery, and turbidity leading to cumulative watershed effects that can imperil the health and sustainability of aquatic ecosystems.

The term “chronic turbidity” has been used to describe the long-duration turbidity regime that includes levels below those that occur during peak stormflows, yet are high enough to cause biological impacts. Evaluating the role of contemporary timber harvest in chronic turbidity was accomplished by assembling stream turbidity datasets from regional watersheds and relating turbidity regimes to both natural and anthropogenic watershed attributes that likely affect turbidity. Recent technological advances allow automated collection of virtually continuous turbidity data, a relatively new means of stream turbidity monitoring that yields datasets of unprecedented detail. Using continuous turbidity data from 27 stations, turbidity at the 10-percent exceedence level was used as a metric for chronic turbidity. This paper presents a portion of a larger analysis by Klein et al. (2008) that evaluated causes of chronic turbidity and effects on anadromous salmonids.

The concept of determining “threshold” rates of timber harvest (i.e., rates above which environmental impacts become excessive) is not

new. Reeves et al. (1993) found harvest rate to be inversely associated with salmonid assemblage diversity. The California Department of Forestry and Fire Protection, in drafting harvest guidelines for the California Board of Forestry, suggests timber harvest exceeding 20 percent of a watershed within a 10-year period (equating to an average annual harvest rate of 2 percent) could result in consideration of a watershed as “sensitive” (Munn and Cafferata 1992). Tuttle (1992) recommends that harvesting 15 percent of a watershed’s area with even-aged management (clearcut) within a decade (equating to an annual harvest rate of 1.5 percent) be used as a threshold for triggering examination of impacts on beneficial uses of water, including fish.

Those working on developing timber harvest rate guidelines in California generally converge on an annual average timber harvest rate of about 1.5 to 2 percent of watershed area as an upper limit or a trigger for more detailed analysis, but efforts to implement harvest rate limits have thus far failed with one exception. In 2006, the North Coast Regional Water Quality Control Board ordered that harvest rates in Elk River and Freshwater Creek (two Humboldt County streams included in this analysis) be limited to approximately 2 pct/yr to minimize harvest-related landslide sediment discharges and reduce nuisance flooding of downstream landowners caused by channel aggradation (North Coast Regional Water Quality Control Board 2006).

Study Area

The 27 north coastal California watersheds for which turbidity data were assembled range in drainage area from 2.9 to 72.8 km², with several smaller watersheds nested within larger ones. All are located in coastal California mountain ranges from about 240 to 500 km north of San Francisco. Because these are small coastal watersheds, snow accumulation and melt are seldom hydrologically significant. Turbidity levels in the region are largely a function of suspended sediment concentrations, and the two are typically well-correlated (Lewis 2002). The largest proportion of stream suspended loads consists of inorganic particles generated from erosion of mineral soils and rock via surface erosion from bared areas, gullies, and mass erosion processes.

The region is subject to high rates of tectonic uplift and strong earthquakes. Slopes are typically steep and soils highly erodible. Rainfall occurs almost exclusively in the winter months, often as multiday intense rainfall events that produce large floods. The combination of these factors results in some of the highest sediment loads in the United States (although there is considerable variability within the region), and while much can be attributed to natural processes, human disturbance can greatly accelerate erosion and sediment delivery to streams.

The study watersheds included several that are virtually pristine redwood forests and several harvested 40+ years ago residing in Redwood National and State Parks. Others are located on private timberlands and subject to varying levels of past and ongoing timber harvest along with minor influences from ranching and residential development. Two of the streams (North and South Forks Caspar Creek) are located within an experimental forest that is the site of long-term watershed research (Lisle 2005).

Methods

To prepare for the analysis, continuous (10- or 15-min sampling interval) turbidity data sets were assembled from a variety of sources, including Federal agencies, a nonprofit group, a private timber company, and individuals (see Klein et al., 2008, for a detailed listing of data contributors). In addition to turbidity, datasets also included continuous stream stage and often discharge data.

Automated turbidity data were collected by deploying sensors in the water column using an articulating boom secured above the stream (see Eads and Lewis, 2002, for a description). An onshore data logger controls sensor operation and records stage and turbidity data. It is rare for an automated turbidity dataset to be free from spurious observations upon retrieval from the field. Raw data must be reviewed and corrected as needed prior to being considered representative of field conditions and thus ready for analysis. Most data contributors provided corrected turbidity data, but some data were provided in raw form and needed corrections.

To make corrections, data were imported to a common spreadsheet and plotted along with stage and (or) discharge data. Such plots are essential for

revealing suspect data, which usually consist of short duration spikes reflecting a leaf or some other object obscuring the sensor optics, or gradually ascending values that reflect algal growth on the sensor's optics. Corrections consisted of reducing suspect values to match valid observations bounding the suspect data. Corrected observations typically composed very small percentages of the full datasets used.

Another important issue in comparative turbidity studies is compatibility (or lack thereof) of data collected using different sensor types or makes. In laboratory testing, Lewis et al. (2007) found that different sensors returned sometimes very different turbidity values when immersed in the same sediment type and concentration. The greatest differences occurred at high turbidities. The present study included data from two sensor types commonly used for stream studies in the region: the OBS-3 sensor (formerly made by D&A Instruments Company, presently made by Campbell Scientific, Inc.) and the DTS-12 sensor (made by Forest Technology Systems, Inc.). A set of equations was developed using the results of Lewis et al. (2007) to convert the data from the OBS-3 to equivalent values for the DTS-12 before conducting turbidity exceedence analyses, as detailed in Klein et al. (2008). Data for the 2005 winter runoff season (WY2005) were assembled and prepared for analysis.

Before performing exceedence analyses, datasets were truncated to only include data from December 2004 through May 2005, the period each season that typically encompasses almost all turbidity events. Although this period excluded several small, early-season storms, several of the datasets assembled had irreparable or no data prior to December. The 10-percent exceedence probability (the turbidity level exceeded 10 percent of the time being considered, or "10% TU") was derived from the continuous data to represent chronic turbidity.

Geographical information system data were obtained for the study watersheds to characterize both the naturally and human-affected propensity for watershed erosion and stream turbidity. Data categories included watershed physiographical characteristics (hypsometry, slope steepness, stream density), slope stability modeling results, history of timber harvest and associated activities (yarding,

road building), attributes of the road network, and rainfall intensities.

Different types of timber harvest impose different disturbance levels per unit area of harvest, with clearcut harvesting and tractor yarding (still widely used) creating the greatest disturbance. Consequently, harvest areas were weighted by silvicultural method according to state guidelines (North Coast Regional Water Quality Control Board 2006) to account for varying levels of ground disturbance and potential water quality impacts. Weighting of the silvicultural methods reduced the actual areas of lower disturbance types, and resultant harvest rate variables were expressed as "clearcut equivalent area." Harvesting, yarding and road building data going back 15 years (1990–2004) before the turbidity data set (WY2005) were assembled from timber harvest plan records kept by the California Department of Forestry and Fire Protection. This period was also broken into three 5-yr periods (1990–1994, 1995–1999, and 2000–2004) to explore the relative importance of harvest age. Clearcut equivalent harvest rate was expressed as the annual average percent of watershed area for individual time periods used.

Multiple regression analyses were performed to determine which watershed variables best explained differences in chronic turbidity among the watersheds. Regressions were performed on two groups: all 27 streams and just the subset of the northernmost 19 streams loosely clustered in Humboldt County, CA. Regressions began by using only the highest correlate with the Y-variable (10% TU) from each watershed variable category, and additional variables were subsequently added if they significantly improved the model (J. Lewis, 2007, U.S. Forest Service, Redwood Sciences Laboratory, personal commun.). The primary diagnostic for evaluating model improvement was Akaike's Information Criterion (AIC) (Sakamoto et al. 1986). The best model was considered to be the one that minimized the AIC.

Results

Rainfall for WY2005 was near normal at about 90 percent of average in the northern portion of the study area, and slightly above normal in the southern portion. Annual average harvest rate (expressed as clearcut equivalent area averaged over the 15 years

prior to the turbidity data record used) ranged from 0 to 3.7 percent. Turbidities at the 10-percent exceedence probability ranged from 3 to 116 formazin nephelometric units (FNU) among the 27 streams. Perhaps more tangible for many readers, the cumulative time above 25 FNU spanned a factor of 100, ranging from 15 to 1,566 hrs. Water in the most turbid streams rarely (and only briefly) fell below 25 FNU (threshold for biological effects) the entire wet season. In contrast, some streams were exceptionally clear, with five located in Federally protected areas only exceeding 100 FNU for 0–2 hrs total in WY2005, and only exceeding 25 FNU for 34–71 hrs total. Table 1 summarizes turbidity results for the study streams grouped by annual average harvest rate.

Table 1. Means (and ranges) of 10-percent exceedence probability turbidities (“10% TU”) and cumulative hours above threshold (25 FNU) for three harvest rate groups.

1990–2004 Harvest rate group	10% TU (range)	Hours >25 FNU
Zero harvest (0%/yr)	13 (3–22)	198
Lower (0.1–1.5%/yr)	20 (4–37)	448
Higher (>1.5%/yr)	61 (26–116)	1,116

Of the variables used for explaining turbidity differences among the watersheds, timber harvest rate averaged over the 15 preceding years was the strongest correlate ($r = 0.71$) with chronic turbidity among the full set of 27 streams. Of the other harvest rate periods investigated (0–5, 0–10, 5–10, and 10–15 yrs prior to the turbidity record), the period 10–15 yrs prior was the next highest correlate ($r = 0.69$). Drainage area was the highest correlate among the natural variables ($r = 0.62$). Each of these variables was directly related to turbidity; i.e., when harvest rate and (or) drainage area goes up, so does turbidity.

The best fit from multiple regression analyses using both the full set of streams ($n = 27$) and the Humboldt County subset ($n = 19$) included just two explanatory variables: clearcut equivalent area for the period 10–15 yrs before the WY2005 turbidity record and drainage area. The full set model resulted in an AIC of 236 and an adjusted multiple r -squared of 0.63. Other models using just harvest rate (including annual harvest rate averaged 0–15 yrs prior to the turbidity record) also performed well.

Regressions using the Humboldt County stream subset ($n = 19$) had a superior fit over that for the full set with an AIC of 158 and an adjusted multiple r -squared of 0.82 (J. Lewis, 2007, U.S. Forest Service, Redwood Sciences Laboratory, personal commun.).

Conclusions

The rate of timber harvest, expressed as annual average clearcut equivalent area for the 15 years preceding the turbidity data record, explained much of the large differences in chronic turbidity among the study watersheds, with drainage area playing a subordinate but still significant role. These findings demonstrate the importance of recent timber harvest and were consistent with the earlier results of Klein (2003) in a similar study.

Basin geomorphic characteristics reflect basin-shaping processes and susceptibility to erosion-accelerating disturbances. To account for this, several variables were derived for the study watersheds to serve as surrogates for natural erosion susceptibility. However, their contribution in explaining turbidity variations was insufficient to be included in the best fit regression models. Certainly, natural factors that determine the inherent erosional susceptibility of hillslopes exert strong control on stream water quality, but with the exception of drainage area, they were overshadowed by human disturbance in this study. By narrowing the geographical range of streams to just the Humboldt County subset, natural variability was reduced and regression results were improved. Further research may ultimately result in more robust variables for characterizing natural erosion susceptibility.

Forest roads are widely recognized as culprits in elevated erosion and sediment delivery in forested steeplands. Reid (1998) modeled effects of fine sediment production from roads using cumulative stream turbidity duration curves. Her results suggested that road-related erosion would cause large increases in chronic turbidity, elevating the duration of turbidities above 100 NTU by a factor of 73.

Contrary to expectations and conventional wisdom, road variables used here had little added statistical value beyond harvest rate and drainage area in explaining turbidity variations, possibly resulting

from incomplete and (or) inaccurate road data. For example, road lengths are probably under-represented in “off-the-shelf” datasets. Perhaps more accurate road data would have elevated the importance of road variables in explaining turbidity. But roads were indirectly accounted for in that they are closely linked to harvest rate: the density of the road network and the intensity of road use rise with increasing harvest rate.

Comparison of turbidity exceedences among watershed harvest class groupings (zero-, low-, and high-harvest rates) showed the low-harvest group to be 58 percent and the high-harvest group to be 369 percent, respectively, above the regulatory limit for northern California streams (20 percent above background). All but two actively harvested watersheds would have been out of compliance with this standard in WY2005. It is important to note that most zero-harvest watersheds included here were not pristine; they had been harvested prior to the period from which harvest data were considered (1990–2004). Although legacy erosion features were no doubt still active in these watersheds, turbidities were far lower than in actively-harvested watersheds.

Although the rate of timber harvest has been acknowledged among California scientists, regulatory agencies, and legislators as a factor in declining water quality and aquatic habitat for some time, little has been accomplished toward enacting regulatory controls. Instead, the regulatory community has largely relied on site-specific best management practices (BMPs) in attempting to prevent degradation of water quality. While BMPs have helped reduce site-specific erosion and resultant turbidity effects from timber harvest, they are neither perfectly conceived nor perfectly implemented, and severe degradation of water quality can still arise in watersheds where too much of the land base is harvested over too short a time period.

Acknowledgments

The author appreciates turbidity data contributions from the U.S. Forest Service Redwood Sciences Laboratory in Arcata, CA, the nonprofit group Salmon Forever, hydrologists Peter Manka and Terry Jo Barber (and her client, Mendocino County Resource Conservation District), Campbell Timber

Company, and support from Redwood National and State Parks in operating turbidity stations in the Prairie Creek watershed. Adona White of the California North Coast Regional Water Quality Control Board secured and provided funding for this project. Jack Lewis, formerly with Redwood Sciences Laboratory, performed the multiple regression analyses that formed a primary basis for my conclusions.

References

- Eads, R., and J. Lewis. 2003. Continuous turbidity monitoring in streams of northwestern California. In J.R. Gray and G.D. Glysson, eds., *Proceedings of the Federal Interagency Workshop on Turbidity and Other Sediment Surrogates*, Reno, NV, 30 April–2 May 2002, unnumbered pages. U.S. Geological Survey, Circular 1250.
- Janda, R.J., K.M. Nolan, D.R. Harden, and S.M. Colman. 1975. *Watershed conditions in the drainage basin of Redwood Creek, Humboldt County, California*. U.S. Geological Survey, Open File Report 75-568.
- Klein, R.D. 2003. *Duration of turbidity and suspended sediment transport in salmonid-bearing streams, north coastal California*. Report to U.S. Environmental Protection Agency, San Francisco, CA.
- Klein, R.D., W.J. Trush, and M. Buffleben. 2008. *Watershed condition, turbidity, and implications for anadromous salmonids in north coastal California streams*. Report to North Coast Regional Water Quality Control Board, Santa Rosa, CA.
- Lewis, J. 2002. *Estimation of suspended sediment flux in streams using continuous turbidity and flow data coupled with laboratory concentrations*. In J.R. Gray and G.D. Glysson, eds., *Proceedings of the Federal Interagency Workshop on Turbidity and Other Sediment Surrogates*, Reno, NV, 30 April–2 May 2002, unnumbered pages. U.S. Geological Survey, Circular 1250.
- Lewis, J., R. Eads, and R.D. Klein. 2007. *Comparisons of turbidity data collected with different instruments*. Report to California Department of Forestry and Fire Protection and the

North Coast Regional Water Quality Control Board,
Santa Rosa, CA.

Lisle, T.E. 2005. Caspar Creek Experimental
Watersheds: Cumulative effects of forest practices
on downstream resources. U.S. Forest Service,
Pacific Southwest Research Station, Science
Perspectives—September 2005 (PSW-SP-005).

Munn, J., and P. Cafferata. 1992. Draft Sensitive
Watershed Criteria. California Department of
Forestry and Fire Protection, Sacramento, CA.

Nolan, K.M., and R.J. Janda. 1995. Impacts of
logging on stream-sediment discharge in the
Redwood Creek basin, northwestern California. In
K.M. Nolan, H.M. Kelsey, and D.C. Marron, eds.,
Geomorphic Processes and Aquatic Habitat in the
Redwood Creek Basin, Northwestern California, pp.
L1–L8. U.S. Geological Survey, Professional Paper
1454.

North Coast Regional Water Quality Control Board.
2006. Watershed-wide waste discharge
requirements for timber harvesting plan activities,
Salmon Creek Corporation, and the Pacific Lumber
Corporation in the Elk River watershed. North Coast
Regional Water Quality Control Board, Order No.
R1-2006-0039.

Reeves, G.H., F. Everest, and J. Sedell. 1993.
Diversity of juvenile anadromous salmonid
assemblages in Coastal Oregon basins with different
levels of timber harvest. *Transactions American
Fisheries Society* 122(3):309–317.

Reid, L.M. 1998. Forest roads, chronic turbidity, and
salmon. In *Abstracts of the American Geophysical
Union 1998 Fall Meeting, San Francisco, CA, 6–10
December 1998*, Abstract no. H11F-05. American
Geophysical Union.

Sakamoto, Y., M. Ishiguro, and G. Kitagawa. 1986.
Akaike Information Criterion Statistics. D. Reidel
Publishing Company, Dordrecht, Netherlands.

Tuttle, A. 1992. Sensitive Watershed Rule Package.
California State Board of Forestry, staff paper.

Facilitating Adaptive Management in the Chesapeake Bay Watershed through the Use of Online Decision Support Tools

Cassandra Mullinix, Scott Phillips, Kelly Shenk, Paul Hearn, Olivia Devereux

Abstract

The Chesapeake Bay Program (CBP) is attempting to more strategically implement management actions to improve the health of the Nation's largest estuary. In 2007 the U.S. Geological Survey (USGS) and U.S. Environmental Protection Agency (USEPA) CBP office began a joint effort to develop a suite of Internet-accessible decision-support tools and to help meet the needs of CBP partners to improve water quality and habitat conditions in the Chesapeake Bay and its watersheds. An adaptive management framework is being used to provide a structured decision process for information and individual tools needed to implement and assess practices to improve the condition of the Chesapeake Bay ecosystem. The Chesapeake Online Adaptive Support Toolkit (COAST) is a collection of web-based analytical tools and information, organized in an adaptive management framework, intended to aid decisionmakers in protecting and restoring the integrity of the Bay ecosystem. The initial version of COAST is focused on water quality issues. During early and mid-2008, initial ideas for COAST were shared and discussed with various CBP partners and other potential user groups. At these meetings, test cases were selected

to help improve understanding of the types of information and analytical functionality that would be most useful for specific partners' needs. These discussions added considerable knowledge about the nature of decisionmaking for Federal, State, local and nongovernmental partners. Version 1.0 of COAST, released in early winter of 2008, will be further reviewed to determine improvements needed to address implementation and assessment of water quality practices. Future versions of COAST may address other aspects of ecosystem restoration, including restoration of habitat and living resources and maintaining watershed health.

Keywords: Chesapeake Bay, adaptive management, online decision support tools, nutrients

Introduction

The Chesapeake Bay is designated as an impaired water body under the Clean Water Act because of poor water quality conditions for fisheries and submerged aquatic vegetation. The Bay is impaired largely because of low dissolved oxygen conditions and poor water clarity conditions due to excess nutrients and sediments. Unless water quality standards are met by 2010, the Chesapeake Bay Program (CBP) partners must prepare a total maximum daily load for the entire Chesapeake Bay. In an effort to meet standards, CBP partners—which include Federal, State, and local governments, and nongovernmental organizations (NGOs)—are implementing voluntary plans to reduce nutrients and sediments in the watershed to improve water quality in the Chesapeake Bay. Additionally, the CBP partners are working to meet Government Accountability Office and Congressional recommendations to develop a comprehensive, coordinated implementation strategy to better utilize existing resources. The CBP partners have developed the Chesapeake Action Plan (CAP), which

Mullinix is a physical scientist, U.S. Geological Survey (USGS) Eastern Geographic Science Center, USGS National Center, Reston, VA 20192, MS 521. Phillips is the USGS Chesapeake Bay Coordinator, USGS MD-DE-DC Water Science Center, 5522 Research Park Drive, Baltimore, MD 21228. Shenk is an environmental scientist, U.S. Environmental Protection Agency Chesapeake Bay Program Office, Annapolis, MD. Hearn is a physical scientist, USGS Eastern Geographic Science Center, USGS National Center, Reston, VA 20192, MS 521. Devereux is a non-point source data analyst, University of Maryland, College Park, MD. Email: ccladino@usgs.gov; swphilli@usgs.gov; shenk.kelly@epa.gov; phearn@usgs.gov; odevereu@chesapeakebay.net.

the application of adaptive management principles to improve the implementation and assessment of management actions (U.S. Environmental Protection Agency 2008). In 2007, a joint collaboration between the U.S. Geological Survey (USGS) and the U.S. Environmental Protection Agency (USEPA) CBP was initiated to develop the Chesapeake Online Adaptive Support Toolkit (COAST), a web-based framework of tools and information to help CBP partners utilize an adaptive management approach to decisionmaking. COAST provides improved access to web-based analytical tools, data, and interpretive science products to help improve the management of the Bay ecosystem.

COAST was designed to enable CPB partners to:

1. understand the CBP restoration goals and the strategies to achieve these goals;
2. select areas in greatest need of mitigation and provide benefit to the Bay;
3. identify partner activities and resources;
4. conduct scenarios using watershed models to identify the optimal combination of management actions;
5. utilize monitoring results to document water quality changes and assess progress; and
6. understand the factors affecting water quality to adapt the mitigation strategies accordingly.

These six components are designed to be both sequential and cyclical and to constitute the structural framework of an active adaptive management strategy for the Chesapeake Bay watershed (Figure 1).

Approach

Before the project began there were several factors to consider in designing the COAST framework. From the beginning the main priority of COAST was to support the major restoration goals described under the CAP. The CAP goals include restoration and protection of fisheries, habitat, water quality, and watersheds, and enhancement of stewardship. Of these goals, water quality was chosen for the initial version of COAST. The CAP also promotes the use of adaptive management in the management process, therefore design. Several approaches to adaptive management, including the U.S. Department of the Interior technical guidance document (Williams et al. 2007), were used to adaptive management became another priority in develop the organizational structure for COAST. Finally, the audience of the initial version of COAST was defined as CBP partners (Federal,

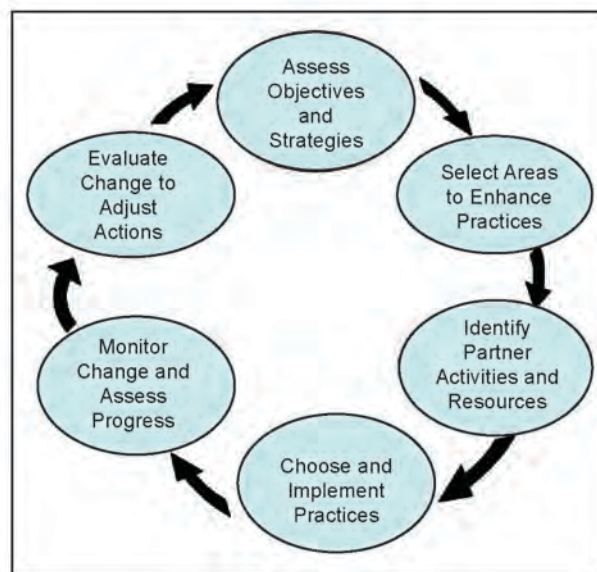

Figure 1. Steps in the Chesapeake Online Adaptive Support Toolkit adaptive management cycle.

State, and local governments and NGOs) who implement water quality management actions to meet the goals of CBP tributary strategies and improve local water quality. To accommodate such a large and diverse group of users, COAST and its decision support tools were chosen to be delivered in a publicly accessible online format.

Selecting data

The COAST was not intended to be a data warehouse, in that storing and serving data would not be a task under the project. Rather, the goal was to use publicly available information to develop selected decision support tools for the steps of the adaptive management cycle in COAST. Preliminary meetings with potential user groups helped define the technical level of information that would be appropriate to highlight in COAST. Instead of gathering many data products for each adaptive management step, key products including results from models, monitoring networks, and CBP Health and Restoration Assessment reports were chosen to support different aspects of COAST. Results from the CBP Health and Restoration Assessments (Chesapeake Bay Program 2008), based on environmental indicators, were used to define restoration goals and determine progress toward aspects of the CBP water quality goal. Results from the USGS SPARROW (SPAtially Referenced Regressions On Watersheds attributes watershed

Watersheds attributes watershed modeling application) (Brakebill et al. 2004) and the CBP watershed models (Chesapeake Bay Program Nutrient Subcommittee 1998) were used to help users select areas for mitigation actions and to choose the suite of actions to be implemented. Results from the CBP nontidal and estuary monitoring networks (Langland et al. 2006) were provided to help assess water quality change to factors affecting water quality, including management practices.

Developing decision support tools

Decision support tools (DSTs) are an interactive way of providing information on a topic for users who need to make specific decisions. DSTs can integrate tabular and static datasets with each other or with spatial data, or can provide analytical functionality to compute derivative data products. DSTs are essential to COAST in providing a way to integrate many types of data needed within the adaptive management process. The first DST developed for COAST, the Nutrient Yields Mapper (NYM), was designed to support restoration management in step 2 of the COAST adaptive management cycle: *Locate areas in greatest need of mitigation*.

The NYM uses Mapbuilder, an open source geographic information systems interface, and Geoserver, a data serving application for hosting web-map services. The tool utilizes output from the USGS Chesapeake Bay, Version 3.0 SPARROW model (Brakebill et al. 2004) to display the spatial distribution of nitrogen and phosphorous yields in subwatersheds within the Chesapeake Bay drainage basin. The SPARROW data are aggregated into quartiles to show relative high and low nutrient yields to major tributary basins and also to the Chesapeake Bay in a map viewer, which can be overlaid with additional information on water quality characteristics. These maps help managers identify the watersheds where actions to reduce nutrient runoff would have the greatest benefit to the Chesapeake Bay and also improve local water quality (Figure 2).

Another DST under development will address step 4 in the COAST adaptive management cycle: *...optimize management actions by developing scenarios using watershed models to choose the optimal combination of*

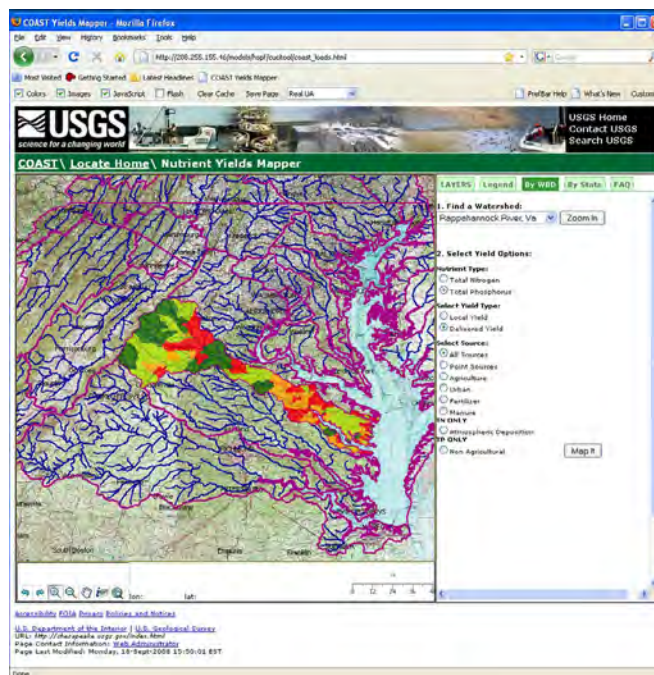

Figure 2. Output from the Chesapeake Online Adaptive Support Toolkit Nutrient Yields Mapper depicting the variation in total phosphorous delivered to the Chesapeake Bay from SPARROW (spatially referenced regressions on watersheds) modeling segments, subwatersheds, within the Rappahannock River watershed.

management actions. An interface to the CBP watershed model is being developed by the University of Maryland and the USEPA-CBP, which will allow local managers to test alternative mitigation strategies for selected watersheds. The tool will compute mass balances for nitrogen and phosphorus, utilizing sources from farm animals, chemical fertilizer, manure, atmospheric deposition, and septic and sewer systems. The tool is designed to provide rapid scenario development for managers to understand factors that reduce loading to the land and contamination by understanding the effect of forecasted land use change, best management practices (BMPs), geographic location, crop production practices, and animal populations. Output will include graphed and tabular reports of manure and fertilizer loading to the land by segment in pounds per acre, BMPs implemented along with their associated nutrient reduction, and bare soil area. A prototype version of the tool will be available in midsummer 2009 with a full version release anticipated in fall 2009.

Test cases

Test cases are being conducted to assess the types of information and methods of presentation that will be most useful to decisionmakers. The test case moves the theory of adaptive management into a real-world application by interacting with small groups of decisionmakers at each management level (Federal, State, county, and NGO) to determine the best mix of existing information and models to improve their management process. In 2008 the COAST team started with agriculturally focused test cases because it would address a large audience of CBP partners.

The objectives of the agricultural test cases are to demonstrate:

- at a Bay-wide and state scale how COAST can be used to prioritize where to direct resources, identify the optimal agricultural nutrient conservation activities, and determine how to assess their effectiveness; and
- to States and counties how COAST can be used as a springboard from which to engage in locally driven analysis to identify opportunities for achieving further nutrient reductions in priority agricultural areas.

These test cases explore several components of the COAST tool associated with water quality and nutrients at regional, State, and county scales. They do not focus on testing the web-based application of the tool, but rather focus on the logic used, the questions asked, and the data layers employed to guide managers in their decisionmaking.

The questions the COAST teams are exploring during these test cases are:

- What are the right questions to ask for the associated decision process?
- What is the most useful information to use in answering those questions?
- How important is additional local data?
- How should the local data be factored into COAST?
- How should we structure the web interface of COAST to maximize utility of the tool to multiple users for multiple purposes?

The COAST team is setting up similar test cases for urban and developed lands to be conducted in the year

2009. Version 1.0 of COAST will be updated based on the outcomes of these test cases.

Results

The development of the COAST tool kit is still at an early stage; however, a number of preliminary findings can be reported. Perhaps the most significant of these is that the decision processes and supporting data for implementing water quality management actions vary greatly at different levels of government and between agencies within levels of government. It is also significant, while the adaptive management process is promoted by the CBP office, that many implementing agencies are focused on the initial steps of the adaptive management cycle (identifying the types and locations of actions) and need to improve the use of monitoring and assessment to make more informed decisions in the future. Most groups we interviewed agreed that information is needed at several geographic scales: the entire watershed, state units (ideally not just the portion in the Chesapeake Bay watershed), and counties. Political boundaries were the most common decisionmaking units, but there was open-mindedness toward providing information on a watershed basis varying from 10-digit hydrologic unit code (HUC) to 12-digit HUC approximately 16 to 391 mi² in size (Natural Resources Conservation Service 2004). Lastly, in deciding the location and type of on-ground mitigation, county managers tend to consider cost sharing and (or) cooperative opportunities more than environmental impact.

Conclusions

While there is progress in use of adaptive management by the CBP partners, the type and scale of information will have to be greatly improved to enhance implementation and assessment of water quality and other ecosystem restoration practices. While watershed-wide information is needed, it is clear that we need to provide information at least at the State scale that can compliment county-scale decisionmaking. Invariably, local knowledge of nutrient sources and local conditions is superior to data that can currently be provided by COAST. However, COAST can provide supplementary information at the Statewide or Chesapeake Bay-wide perspective to help verify county priorities and more closely link county to State and regional priorities. There is also a need for additional datasets such as state information on stream impairments based on the

USEPA Clean Water Act section 303d water quality standards and section 305b integrated assessment reports (U.S. Environmental Protection Agency 1972) to be integrated into COAST, as well as higher spatial resolution datasets such as 10-digit HUC or 12-digit HUC level that extend beyond the Chesapeake Bay watershed boundary to cover the entire multistate region. The data that make up the basis of COAST information also need to be timelier to reflect current conditions. Some ability for local users to upload finer-scale data into COAST has obvious advantages and will be considered as a new functionality is added to the tool kit in the future. Although COAST emphasizes the adaptive management cycle in its structure, there is a need to make it clear that users can utilize any component of the adaptive management process depending on their current status of implementation of management actions. This year's test cases were very successful in defining a product for Chesapeake Bay managers. It was also useful for selecting priority watersheds based on environmental data and not just local opportunity. Future test cases in other subwatersheds where multiple types of information exist will need to be conducted to enhance COAST's effectiveness at local scales.

Acknowledgments

The authors appreciate the reviews of Andrew LaMotte and Susan Price.

References

- Brakebill J.W., and S.D. Preston. 2004. Digital data used to relate nutrient inputs to water quality in the Chesapeake Bay Watershed, Version 3.0. U.S. Geological Survey, Open-File Report 2004-1433.
- Chesapeake Bay Program. 2008. Chesapeake Bay Health and Restoration Assessment. Chesapeake Bay Program partners, (CBP/TRS-291-08; EPA-903-R-08-002), Annapolis, MD.
- Chesapeake Bay Program Nutrient Subcommittee. 1998. Chesapeake Bay Watershed Model Application and Calculation of Nutrient and Sediment Loadings. U.S. Environmental Protection Agency, Chesapeake Bay Program, Annapolis, MD.
- Langland M.J., J.P. Raffensperger, D.L. Moyer, J.M. Landwehr, and G.E. Schwarz. 2006. Changes in

streamflow and water quality in selected nontidal basins in the Chesapeake Bay watershed, 1985–2004. U.S. Geological Survey, Scientific Investigations Report 2006-5178.

Natural Resources Conservation Service. 2004. Federal Standards For Delineation Of Hydrologic Unit Boundaries, ver. 2.0. U.S. Department of Agriculture, Natural Resources Conservation Service.

Williams, B.K., R.C. Szaro, and C.D. Shapiro. 2007. Adaptive Management: The U.S. Department of the Interior Technical Guide. U.S. Department of the Interior, Adaptive Management Working Group, Washington DC.

U.S. Environmental Protection Agency. 1972. Clean Water Act (33 U.S.C. 1251 et seq.). [online] URL: <http://www.epa.gov/lawsregs/laws/cwa.html>. Accessed 23 September 2008.

U.S. Environmental Protection Agency. 2008. Strengthening the Management, Coordination, and Accountability of the Chesapeake Bay Program: Report to Congress. U.S. Environmental Protection Agency Chesapeake Bay Program Office, (CBP/TRS-292-08), with Chesapeake Bay Program partners, Annapolis, MD.

Poster Session and Field Trip Orientation—Abstracts

Reflections on the July 31, 1976, Big Thompson Flood, Colorado Front Range, USA

R.D. Jarrett, J.E. Costa

Abstract

In the early evening of Saturday, July 31, 1976, a large stationary thunderstorm released as much as about 305 mm of water in a few hours that produced extraordinary flash flooding, primarily in the Big Thompson River Basin. The flood caught residents and tourists by surprise. The sudden flood that churned down the narrow Big Thompson Canyon scoured the river channel that night and caused over \$116 million (2006 dollars) in damages. The tragedy claimed the lives of 144 people, including two law enforcement officers trying to evacuate people in danger, and there were 250 reported injuries. Hundreds of other people narrowly escaped with their lives.

This poster presents a summary of the hydrologic conditions of the 1976 flood, describes some of the advances in U.S. Geological Survey flood science as a consequence of this disaster, and provides a reminder that such floods will occur again. Important contributions to flood science as a result of the 1976 flood include the development of paleoflood methods to document the number, magnitude, and age of floods that occurred prior to streamflow monitoring, which are used to improve flood frequency estimates, help improve flood warning systems, and validate the critical-depth method for improving estimates of extreme flood discharges in higher-gradient rivers. The poster also provides background information for the associated Wednesday field trip to the Big Thompson River watershed. These methods and data on large floods can be used in many mountain-river systems to help us better understand flood hazards and plan for the future.

Jarrett is a research hydrologist and Costa is a Scientist Emeritus with the U.S. Geological Survey, Denver, CO, and Vancouver, WA, respectively. Email: rjarrett@usgs.gov; jecosta@usgs.gov.

Climate-Induced Changes in High Elevation Nitrogen Dynamics

J.S. Baron, T.M. Schmidt, M.D. Hartman

Abstract

Mountain terrestrial and aquatic ecosystems are responsive to external drivers of change, especially climate change and atmospheric deposition of nitrogen. This is of interest to public land managers with responsibilities for protecting Class 1 Clean Air Act Areas and Wilderness from human-caused alterations. We explored the consequences of an overlay of climate change on an alpine and subalpine watershed in the Colorado Front Range that has long been the recipient of elevated atmospheric N deposition. Mean annual nitrate concentrations increased by 33 percent, and mean annual nitrogen export has increased by 28 percent from Loch Vale watershed since 2000. Measured inorganic nitrogen values since 2000 are the highest observed since monitoring began in 1982. The substantial increase in nitrogen dynamics comes as a surprise, since atmospheric N deposition has not increased during this period. Coincident with the increase in watershed nitrogen loss and stream nitrogen concentrations, there has been a period of below normal precipitation and an increase in temperatures, especially mean annual temperature, which increased from a mean of 1.3°C for the years 1985–1999 to a mean of 1.7°C for 2000–2006. The temperature increase is driven by a strong increase in July mean and minimum temperatures. Nitrate concentrations, as well as the weathering products calcium and sulfate, were higher for the period 2000–2006 in rock glacier meltwater at the top of the watershed, suggesting minimal influence of alpine and subalpine vegetation and soils. We conclude the observed N increases in Loch Vale are climatically induced, caused by melting ice in glaciers and rock glaciers that have exposed microbially active sediments. The phenomenon observed in Loch Vale may be indicative of nitrogen release from ice features worldwide as mountain glaciers retreat. In regions that are chronically ultra-oligotrophic, additional nitrate may stimulate algal productivity and affect species assemblages, such as we have already observed.

Baron is a research ecologist with the U.S. Geological Survey, Fort Collins Science Center, Fort Collins, CO, and senior research scientist with the Natural Resource Ecology Laboratory, Colorado State University. Schmidt is a Mendenhall postdoctoral fellow with the U.S. Geological Survey, Mineral Resource Program, Denver, CO. Hartman is a research associate with the Natural Resource Ecology Laboratory, Colorado State University, Fort Collins, CO. Email: jill@nrel.colostate.edu; tschmidt@usgs.gov; melannie@nrel.colostate.edu.

Potential Climate Impacts on the Hydrology of High Elevation Catchments, Colorado Front Range

M.W. Williams, K.H. Hill, N. Caine, J.R. Janke, T. Kittel

Abstract

Potential climate impacts on the hydrology of two seasonally snow-covered catchments is evaluated using 24 years of data from Niwot Ridge Long Term Ecological Research Site, CO. At the larger (220 ha), higher elevation (3,570 m) GL4 catchment, annual discharge did not change significantly based on nonparametric trend testing. However, October streamflow volumes and groundwater storage did increase, despite drought conditions near the end of the record in 2000–2004. In contrast, at the smaller (8 ha), lower elevation (3,400 m) MART catchment, annual discharge decreased significantly over the study period with the most substantial changes in July–September. The study period was separated into “wet,” “normal,” and “dry” years based on the 75th and 25th quartiles of annual precipitation. Results indicate that MART is particularly sensitive to changes in precipitation with dry years exhibiting decreased snowmelt peak flows, earlier snowmelt timing, decreased annual discharge, and reduced late-season flows. GL4 was less susceptible to changes in precipitation, and surprisingly late-season flow volumes (Sept.–Oct.) were not significantly different among wet, normal, and dry conditions. Glacial melt from the Arikaree glacier may account for up to 43 percent of the increase in late-season flows based on ablation measurements. We downscaled a regional permafrost model based on topoclimatic variables to assess whether subsurface ice within permafrost and rock glaciers could account for the remaining deficiency. Results suggest that with only 1°C of warming over one-third of permafrost area would be lost. Over the study period mean annual minimum temperatures increased by 0.6° decade⁻¹, with some of the most prominent increases occurring in July (1.5°C decade⁻¹). Additionally, limited ground temperature measurements at an active rock glacier indicate a 1°C increase over the past decade. This suggests that the source of late-season streamflow at GL4 has shifted towards permafrost meltwater in recent warm, dry years. This study shows that seasonally snow-covered catchments are particularly sensitive to changes in climate, but the hydrologic response may depend on landscape characteristics.

Williams, Hill, Caine, and Kittel are with the University of Colorado, Institute of Arctic and Alpine Research. Janke is with Metropolitan State College of Denver. Email: markw@culter.colorado.edu; kenneth.hill@colorado.edu; cainen@colorado.edu; jjanke1@mscd.edu; kittel@colorado.edu.

Poster Session and Field Trip Orientation— Manuscripts

Monitoring Hydrological Changes Related to Western Juniper Removal: A Paired Watershed Approach

T.L. Deboodt, M.P. Fisher, J.C. Buckhouse, John Swanson

Abstract

Since 1934, western juniper has increased its hold on eastern Oregon rangelands. U.S. Forest Service reports that juniper acreage has increased from 1.5 million acres to over 6 million acres in 1999. Previous studies have shown that water use by juniper can exceed 30 gallons per day when adequate soil moisture is present. Increased juniper dominance has been implicated in the desertification of Oregon's rangelands. Groundwater mitigation, reintroduction of steelhead into the upper Deschutes River basin, and changes in laws affecting surface water right allocations have driven public policy to look at how water is currently being used and how changes in water use (water law) could affect water availability. Vegetative modeling has shown that 9 to 35 trees per acre are enough to utilize all the precipitation delivered to a site in a 13-in annual precipitation zone. Earlier studies suggest that a minimum of 17 in of annual precipitation is required to measure a water yield response associated with vegetative manipulation. In 1993, the Camp Creek Watershed study area was established to monitor the effects of juniper removal on hydrologic processes. In 2005, following 12 yrs of pretreatment monitoring in the 2 watersheds (Mays and Jensen) all post-European aged juniper (juniper <140 years of age) were cut from the treatment watershed (Mays). Analysis indicated that juniper reduction significantly increased late season spring flow by

225 percent ($\alpha > 0.05$), increased days of recorded groundwater by an average of 41 days ($\alpha > 0.05$), and increased the relative availability of late season soil moisture at soil depths of .76 m (27 in) ($\alpha > 0.1$). Ephemeral channel flow did not show a predictable trend following 2 yrs of post treatment measurements. The Camp Creek project illustrated that, for this system, managing vegetation for water yield may be obtainable at a much lower precipitation threshold than what was previously understood.

Keywords: paired watershed, water yield, western juniper, range restoration

Introduction

According to U.S. Forest Service publication PNW-GTR-464, "Western Juniper in Eastern Oregon," western juniper's dominance in eastern Oregon has increased 5-fold since 1934 (420,000 acres to 2,200,000 acres) (Gedney et al. 1999). The result of this significant shift in plant community dominance has been reduced forage production, increased soil erosion, and reduced infiltration rates. Based on individual tree water use models and field observations, it has been speculated that the expansion of western juniper has been, at least in part, responsible for the desertification of these landscapes. Based on water use models for individual trees, the U.S. Forest Service estimates that mature western juniper tree densities, ranging from 9 to 35 trees per acre, are capable of utilizing all of the available soil moisture on a given site. Research has shown that soil loss from sites with higher than the natural variation of western juniper cover is an order of magnitude greater than similar sites that are still within their natural range of variation (Buckhouse and Gaither 1982).

Established in 1993, the Camp Creek Watershed Study Area was created to monitor water quantity

Deboodt is an associate professor and extension agent, Oregon State University Extension Service, Crook County, Prineville, OR 97754. Fisher is associate professor and department head, Forestry Program, Central Oregon Community College, Bend, OR 97701. Buckhouse is professor and extension watershed specialist, Oregon State University, Department of Rangeland Ecology and Management, Corvallis, OR 97331. Swanson is a rangeland specialist, Bureau of Land Management, Prineville District, Prineville, OR 97754.

and timing associated with juniper control. Channel morphology, hill slope erosion, and changes in vegetation were also monitored. The project involved the use of a paired watershed study format. The paired watershed project is located approximately 60 mi southeast of Prineville, OR.

Two watersheds (Mays and Jensen) were identified in the Camp Creek Drainage, a tributary of the Crooked River. The project consisted of the treatment (cutting juniper) of one of the paired watersheds totaling approximately 250 acres with the other watershed serving as the untreated control. The U.S. Bureau of Land Management (BLM) Prineville District cut approximately 200 acres of western juniper in Mays watershed. The cutting was initiated in October 2005 and was completed in April 2006.

The elevation of the project area ranged from 4,500 to 5,000 ft with an average annual precipitation of 13 in. The historic vegetation type was mountain big sagebrush/Idaho fescue. The site is currently dominated by western juniper with a sparse understory of shallow rooted perennial grasses and forbs. Since 1993, the two watersheds have been monitored for similarities and differences.

Project objectives

- Evaluate hydrologic changes following the cutting of post-European aged juniper (trees established since mid-1800s).
- Evaluate changes in hill slope erosion and channel morphology following the cutting of post-European aged juniper.
- Evaluate changes in plant community composition following the cutting of post-European aged juniper.

The majority of the two watersheds consisted of public land, administered by the BLM Prineville District (75 percent Mays, 86 percent Jensen). The remaining portions of each watershed were owned by the Hatfield High Desert Ranch. The BLM—in cooperation with the Crook County Soil and Water Conservation District (SWCD), the permittee (Hatfields), and the Oregon State University (OSU) Department of Rangeland Ecology and Management—identified the paired watersheds as an area of interest because of the opportunities the study provided to monitor changes in water yields

relative to juniper control. Access to the site is from the Camp Creek/Bear Creek road.

Methods

Establishment of the study and initiation of monitoring began in 1993. Each watershed was delineated by the location of a continuous recording flume placed in the channel at the lowest point of each watershed. Flow was measured and recorded with the aid of a data logger. Precipitation inputs were first measured with the use of a Belfort Universal Rain Gauge, and a weather station was added to each watershed in 2004 to record air temperature, precipitation, wind speed and direction, solar radiation, leaf wetness, relative humidity, and snow accumulation.

In 2004, additional monitoring was added to the watersheds (Figure 1). Within each watershed, a spring was improved and flow measured. Six shallow wells were placed across the valley bottoms of each watershed near the flume location for the purpose of measuring depth of groundwater. Soil moisture and soil temperature probes were installed at 2 locations within each watershed and placed at multiple soil depths.

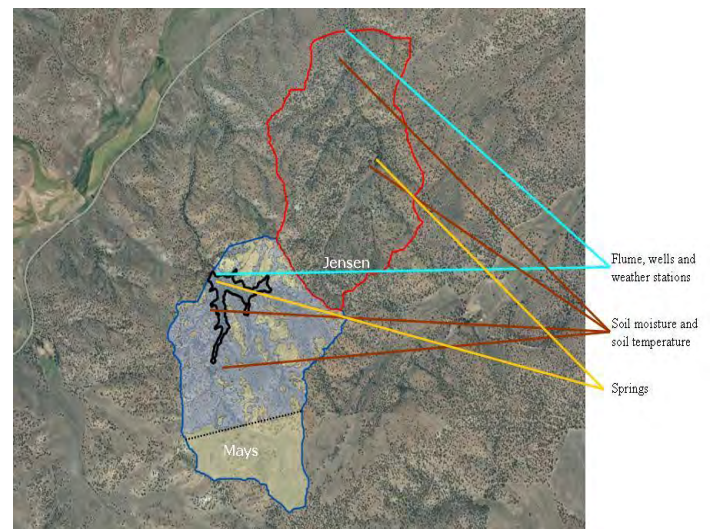

Figure 1. Location of monitoring stations.

All monitoring of weather, spring flow, channel flow, soil moisture, and depth to water was done through satellite uplinks; data is available for viewing on the website <http://ifpnet.com>.

Results

Spring flow

Figure 2 illustrates the differences in output between the two springs and the differences between years. Spring flow is dependent on timing, type, and amount of precipitation. Base flow, the flow which is least likely to be influenced by a recent precipitation event or snowmelt period, is late season flow. Late season flow is defined as the period between July and November. The first two sets of bars represent the pretreatment years (2004–2005) and the last 3 sets of bars show the changes in flow after treatment (October 2005).

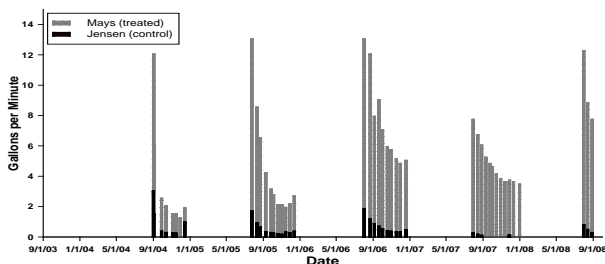

Figure 2. Differences in late season spring flow before and after treatment.

Table 1 shows the t-test results for comparisons of late season flow (lowest flow recorded) between the two watersheds and the years before (2004–2005) and after (2006–2007) treatment. The one tailed P-value is significant at $\alpha = 0.05^{**}$.

Table 1. T-Test for spring flow data, lowest flow recorded (GPM).

Year	Watershed		Diff.	Mean	Variance
	Mays	Jensen			
2004	1.87	0.20	1.67		
2005	1.90	0.13	1.77	1.720	0.00500
2006	4.80	0.23	4.57		
2007	3.6	0.00	3.60	4.085	0.47045
	Difference			2.365	
	Standard error			0.487	
	t-test			4.8505805	
	One tailed P-value			0.019**	

Wells

Well data, in addition to depth measured, provides insight to the timing or availability of subsurface water. The length of groundwater availability could

be an indicator of watershed function (Table 2). Increases in length would indicate an improved hydrologic condition. A review of the data (t-test indicates that changes in the average number of days in which water was recorded in the wells increased in Mays as a result of cutting the trees (p -value = 0.0152). Using a Wilcoxon rank test the wells in Mays post-treatment, recorded a greater increase in the number of days that water was recorded when compared to the control watershed, Jensen (p -value = 0.013).

Table 2. Comparison of average number of days of well water for the watersheds. Pre- and post-treatment years consist of 2 yrs each.

Watershed	Well	Pre-treat	Post-treat	Diff.
Mays	1	112.5	128.5	16
	2	119.5	135	15.5
	3	195.5	285	89.5
	4	195.5	209	13.5
	5	156	197	41
	6	269.5	342.5	73
Jensen	1	70	82	12
	2	78.5	89	10.5
	3	283.5	296	12.5
	4	314.5	361.5	47
	5	283.5	296	12.5
	6	167.5	141	-26.5

Soil moisture

Observing the lowest readings of the year within each watershed illustrated the amount of “water savings” that was carried over from one year to the next (Figure 3). Evaluating the change in “water savings” over years helps to see if that change was associated only with precipitation, or if increases might have been due to the lack of deep-rooted vegetation (the cutting of the juniper). If it was due to the removal of deep-rooted vegetation, then excess soil moisture could move through the soil profile and into sub-surface water storage and flow.

Individual probe readings were averaged by location within the soil profile and by site for each watershed. ANOVA (analysis of variance) showed that the observed increase was significant ($\alpha = 0.1^*$) for the difference between 2006 and 2005 and for the average increase difference of 2006–07 combined and 2005 when comparing Mays with Jensen. Table 3 shows the results of this test for the combined years 2006–07 compared to 2005.

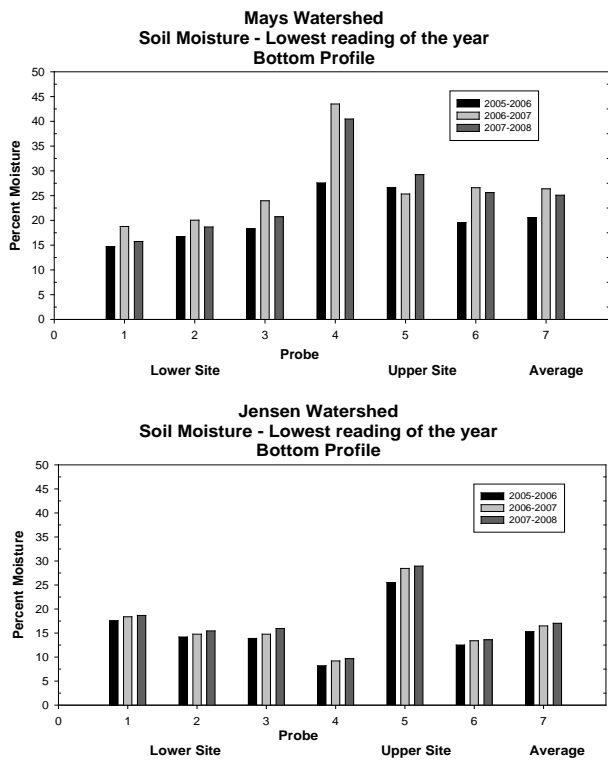

Figure 3. Example of changes in soil moisture. 1 year pre-treatment and 2 years post treatment.

Table 3. Significance of end of year soil moisture accumulation post- vs. pre-treatment.

Year	Probe (Location)	P-value
2006–07 vs. 05	Bottom (0.27 in)	0.1002*
2006–07 vs. 05	Middle (0.18 in)	0.1796
2006–07 vs. 05	Top (0.7 in)	0.6132

Channel flow

Channel flow in the two watersheds is ephemeral. These channels only have flow during periods of snowmelt and extreme summer thunderstorm activity. Ephemeral channels tend to be more influent in relation to the groundwater than perennial flows contributing to groundwater rather than groundwater contributing to channel flow.

Ephemeral channel flows or days of flow did not show a relationship to the treatment. Recorded channel flow occurs during the spring and early summer months and is usually associated with the snow melt period. In 1996 and 2004 total annual days of flow were greater than days of springtime channel flow, a result of late summer thunderstorms and early fall rain. In all years but one, Mays flowed

longer than Jensen. In 1998, Jensen flowed for more days when compared to Mays. In 2007, while length of flow was greater in Mays, Jensen’s flow as measured in accumulated cubic feet per second was greater than Mays’ flow.

Of special note in the observation of these systems was the winter of 2006, following the cutting of juniper in Mays. The snow pack, which began its accumulation in December 2005 was static at approximately 16 in. December and early January rain events saturated the snow pack. While no water content measurements were taken, field notes indicate that the snow was saturated and frozen on top. Field notes also indicated that the snow pack was solid enough for researchers to be able to walk on top of the snow without breaking through. As mentioned earlier, soil temperatures during this period did not drop below 32°F for either watershed. Channel flow in Mays began on 7 January 2006. Flow was recorded through mid-June 2006. In contrast, flow in Jensen did not begin until 1 April 2006 and ceased to flow by early May. During this period, all observations for both watersheds indicated that flow was generated exclusively from bank seepage and that no evidence of overland flow was observed for either watershed.

In contrast, during the winter of 2007, very little snow pack was accumulated. Bare ground was observed in both watersheds (50–70 percent of the landscape) with snow accumulation areas measuring less than 6 in. Soil temperatures in early February were approximately 22°F. An early February storm produced a rain on snow event. Flow was recorded in both watersheds and evidence was observed which indicated the majority of channel flow originated as overland flow. Sediment movement was observed on the hill slopes and in the channels. Sediment deposits had to be removed from both flumes. These two different observations help to illustrate the high variability within these systems and the difficulty in connecting channel flow data to treatment effects, especially during the first two years following treatment.

Management Implications

A healthy, functioning watershed is one that captures, stores and safely releases the precipitation that is delivered to the site. Land management decisions should include looking for ways to

increase opportunities for precipitation to infiltrate into the soil profile (vegetation management), moving excess moisture into sub-surface storage and groundwater, slowly releasing that water to minimize the risk of soil loss and channel bank and bed instability (Fisher et al. 2008). Hibbert (1983) and others have suggested that there would be no water yield increase as a result of vegetation manipulation (juniper cutting) in precipitation zones where annual precipitation was less than 4,300 mm (17 in). Any change to the water budget would only yield an increase in soil moisture, improving herbaceous vegetative production.

The 30-yr average annual precipitation at Barnes Station (U.S. Geological Survey weather station) located approximately 10 mi east of the study site is 349 mm (13.75 in). Precipitation over the last 4 yrs on the study site has ranged from 278 mm (10.95 in, 80 percent of average) to 449 mm (17.68 in, 129 percent of normal). Both the high and low precipitation years occurred during the post-treatment phase of the study.

A review of the data collected over the course of the last 13 yrs indicated that the cutting of post-European aged juniper has changed the water balance equation. Analysis of the first 2 yrs following treatment has shown that spring flow, groundwater, and soil moisture have all increased when compared to pre-treatment levels. Comparisons of ephemeral channel flows did not show as clear a trend (data not presented here). Ephemeral channels tend to be more influent in relation to the groundwater, contributing to groundwater rather than groundwater contributing to channel flow.

In the uplands, management implications suggest that with juniper removal, herbaceous vegetation can create a more uniform groundcover across the hillslope. Reduced bare ground results in increased infiltration opportunity and decreased soil erosion. Improved hydrologic function of the uplands can maintain site stability and fertility.

Within the riparian area, management implications point to the opportunity to increase spring flow for livestock, wildlife, and domestic use along with some mitigation of water diversion. Late season low flows limit land management alternatives. Increasing flows by cutting juniper could partially

offset this limitation. Changes in groundwater may have downstream effects, delaying the time it takes water move through the system and by adding to channel or perennial stream flow downslope.

By combining the upland and riparian benefits of juniper removal, the system will begin to move toward a watershed that is functional in its ability to capture, store, and safely release water while providing a site that is productive and capable of being managed for sustainable use.

Acknowledgments

This research project was initially supported through a grant from the U.S. Environmental Protection Agency with Dr. John Buckhouse (OSU), Mel George (University of California–Davis), and Sherm Swanson (University of Nevada–Reno) providing grant leadership. Additional funding was provided by a Bureau of Land Management Science Grant (thanks to Michelle McSwain, Prineville District) and the Oregon Watershed Enhancement Board. Other financial support was provided by Crook County Taylor Grazing Board, Crook County Extension Service District, and the Secure Rural Schools and Community Self-Determination Act of 2000: Title II. Authors appreciate the reviews of Tamzen Stringham and Tony Svejcar.

References

- Buckhouse, J.C., and R.E. Gaither. 1982. Potential sediment production within vegetative communities in Oregon's Blue Mountains. *Journal of Soil and Water Conservation* 37(2):120–122.
- Fisher, M.P., T. Deboodt, and J. Buckhouse. 2008. Channel geomorphologic changes and hillslope soil movement following juniper treatment on Camp Creek paired watershed study. In *Building Bridges: Grasslands to Rangelands*, Proceedings of the 2008 Joint Meeting of the Society for Range Management and the America Forage and Grass Council, Louisville, KY, 26–31 January 2008, Abstract no. 2402. Society for Range Management, Wheat Ridge, CO.
- Gedney, D.R., D.L. Azuma, C.L. Bolsinger, and N. McKay. 1999. Western juniper in eastern Oregon. U.S. Department of Agriculture, Forest Service,

Pacific Northwest Research Station, General
Technical Report PNW-GTR-464.

Hibbert, A.R. 1983. Water yield improvement
potential by vegetation management on western
rangelands. *Water Resources Bulletin* 19(3):375–
381.

Larsen, R.E. 1993. Interception and Water Holding
Capacity of Western Juniper. Oregon State
University. Ph.D. dissertation. Corvallis, OR. 172 p.

A Study on Seed Dispersal by Hydrochory in Floodplain Restoration

H. Hayashi, Y. Shimatani, Y. Kawaguchi

Abstract

A floodplain has a function as a retarding basin and provides habitats for various organisms inhabiting the wetland. It is thought that this function is kept by transportation of various materials (including seed of plants) by flood water. Flooding events can be an important process for seed dispersal to the floodplain. In this study, we examined sediment transported by flood water at the artificial restored floodplain (Azame-no-se). We found that seeds were transported by flood water to the floodplain. We also found distances from the flow-in site were related to the seed dispersal in the floodplain.

Keywords: floodplain, river restoration, seed dispersal, hydrochory

Introduction

A floodplain is land generated by flooding or moving of river channels and composed by the deposit transported from the river. A floodplain has a function as a retarding basin and provides habitats for various organisms inhabiting the wetland. However, floodplain wetland area has been decreasing sharply by urban development and river regulation. Therefore, floodplain restoration projects are currently conducted all over the world, including the Kissimmee River (Middleton 1999) in Florida in the United States and the Skjern River (Danish Ministry of Environment and Energy 1999) in Denmark in Europe. In Japan, the Ministry of Land Infrastructure and Transport is implementing restoration of a floodplain wetland in the Azame-no-se area of a mid-order stream of the Matsuura River.

Hayashi is a student, Kyushu University, Department of Ecology and Civil Engineering, Japan. Shimatani is a professor/research leader and Kawaguchi is a research scientist, both at Kyushu University, Department of Ecology and Civil Engineering, Japan. Email: river3@civil.kyushu-u.ac.jp.

In recent years, hydrochory (seed dispersal by water) has been focused on plant dispersal in riparian areas. For example, Goodson et al. (2003) found a correlation between vegetation establishment and weight or grain size of sediment that was transported by water. Jansson et al. (2005) found that hydrochory increases species richness of riparian plants. However, these studies were focused on seed dispersal by stream at normal time (not flooding time) stream-stage with seed traps installed for a long period (months), which cannot exclude the possibility of anemochory (seed dispersal by wind), so it is insufficient to show that the seed dispersal was surely performed by hydrochory.

We aimed to find the evidence of hydrochorous seed dispersal to a floodplain by flood water and to explain how the seeds disperse in a floodplain by flood water. Specifically, we examined sediment transported by flood water at the artificial restored floodplain, Azame-no-se. We also assessed the process of vegetation regeneration in the Azame-no-se area.

Methods

Study area

Aiming at “rehabilitation of a floodplain wetland” and “restoration for a close relationship of humans with wildlife,” the Azame-no-se Rehabilitation Project began in The Matsuura River in 2003. The rehabilitated Azame-no-se Wetland is an approximately 1,000-m (3,280-ft) long and 400-m (1,310-ft) wide floodplain and has an area of 6 ha. The wetland serves both as a storage basin of floodwater (except for the design flood discharge) and a foothold of wetland restoration activities. The Azame-no-se area was used as rice paddy field and did not have any hydrological connections to the Matsuura River before the restoration. After the restoration, Azame-no-se area was excavated about 5 m, and the hydrological connectivity was restored. The site consists of some ponds, creeks, and a terraced rice paddy, with each nurturing a variety of creatures. The Azame-no-se area is currently hydrologically connected to the Matsuura River only by the creek, and at flooding

time, the floodwater flows into the whole site. Sediments and many living things (including seeds of plants) also flow into the area with flood water.

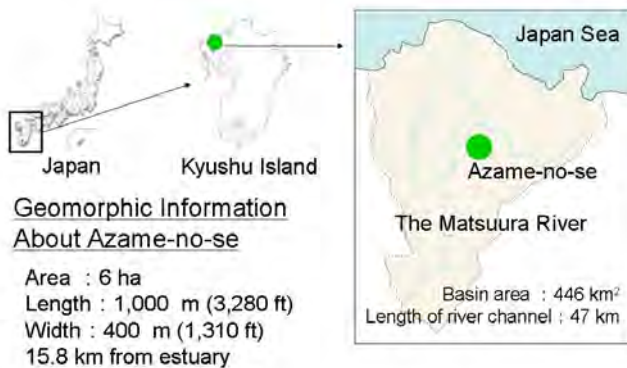

Figure 1. Geographical location of the study site.

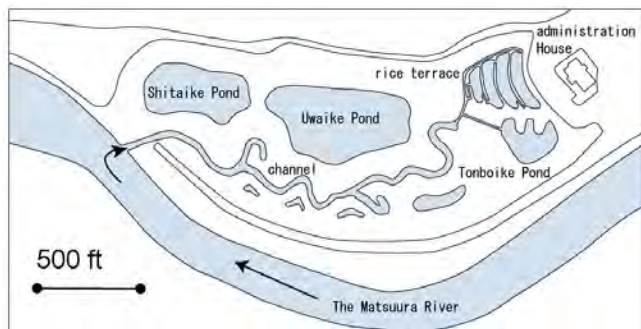

Figure 2. Overview of the Azame-no-se area.

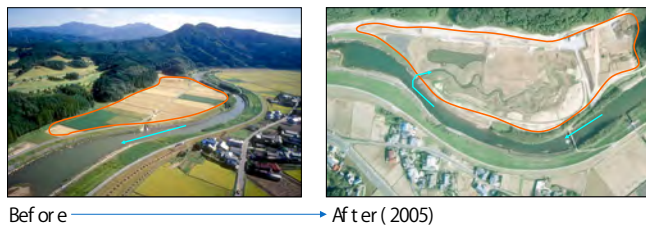

Figure 3. Photos of the Azame-no-se area (left: before rehabilitation; right: after rehabilitation).

Field investigation

Approximately 40 sampling points were established to collect seeds in flooding sediment at Azame-no-se in June 2004 and April 2006. Six frames of seed traps, with each made of a stainless frame (20×20 cm) covered with an unwoven cloth, were installed at each sampling point. At each point, four frames were used for germination trial to determine the number of germinated seeds and the number of species, and the remaining two frames were used for sediment analysis to determine dry weight and median particle size of sediment.

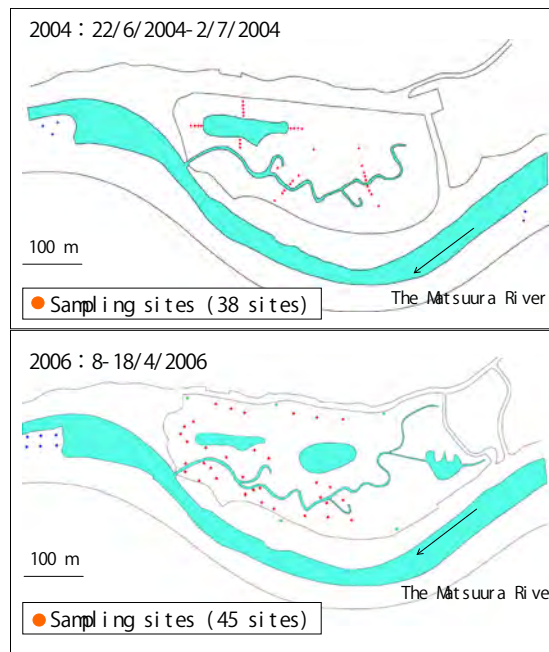

Figure 4. Sampling sites of field investigation (upper: 2004; bottom: 2006).

Germination trial

Sediment samples were promptly removed to germinate them after each flooding event. We analyzed the germination trial by seedling emergence method. We used wooden plant pots in the trial, with one plant pot for one sediment sampling site. Each plant pot was kept wet during the trial. Some plants considered as the same species were planted out to another pot together to identify the species of germinated plants, and the plants were cultivated until they showed their characteristics. Then, we determined the number of germinated seeds and the number of species.

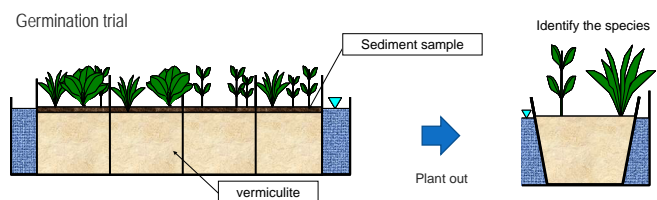

Figure 5. Image of germination trial.

Results

Germination trial

From the germination trial, 6,229 seedlings (1,025 seedlings/m²) were identified to 96 species in 2004, and

3,178 seedlings (441 seedlings/m²) to 77 species in 2006. Many identified plants were arable weed including *Rorippa islandica* and *Lindernia procumbens*. Some marshy and alien plants were also found. The marshy species included *Gratiola japonica* and *Rotala pusilla*. Among the alien species, *Eragrostis curvula* and *Solidago altissima* L. were found, which have threatened Japanese native plants.

Relationship between the number of seedlings and distance from flow-in site

We categorized seed trap sites to three groups depending on the distance from the flow-in site: 0–50 m, 50–100 m, and 100–200 m. Then we compared the number of seedlings and weight of sediments among groups. We made the comparison using data from 2004 and 2006. We found that the number of seedlings tended to be larger at the seed trap site located near the flow-in site.

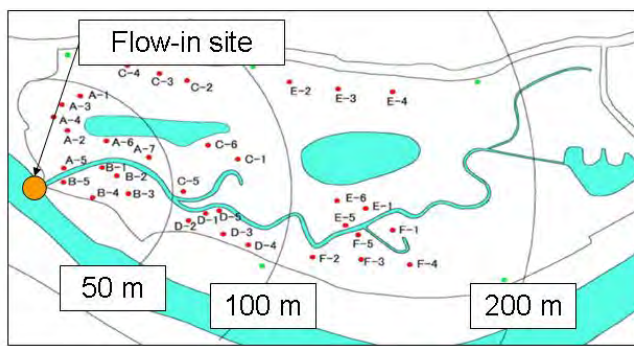

Figure 6. Categorized seed trap sites.

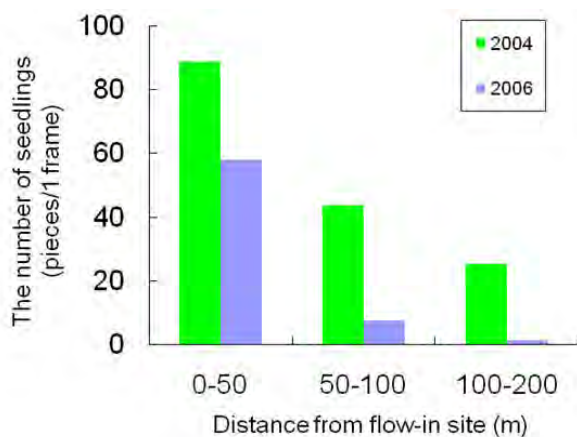

Figure 7. Relationship between the number of seedlings and distance from flow-in site.

Conclusions

This study shows that seeds are transported by flood water to the floodplain. Many identified plants were arable weed, but some marshy plants were also found, including some endangered species. We also found that distance from the flow-in site was related to the seed dispersal in the floodplain.

References

Danish Ministry of Environment and Energy. 1999. The Skjern River Restoration Project. Danish Ministry of Environment and Energy, National Forest and Nature Agency, Copenhagen.

Goodson J.M., A.M. Gurnell, P.G. Angold, and I.P. Morrissey. 2003. Evidence for hydrochory and the deposition of viable seeds within winter flow-deposited sediments: The River Dove, Derbyshire, UK. *River Research and Applications* 19:317–334

Jansson R., U. Zinko, D.M. Merritt, and C. Nilsson. 2005. Hydrochory increases riparian plant species richness: A comparison between a free-flowing and a regulated river. *Journal of Ecology* 93:1,094–1,103

Middleton, Beth. 1999. *Wetland Restoration, Flood Pulsing and Disturbance Dynamic*. John Wiley & Sons, New York.

Lessons Learned in Calibrating and Monitoring a Paired Watershed Study in Oregon's High Desert

Michael Fisher, Tim Deboodt, John Buckhouse, John Swanson

Abstract

The use of the paired watershed approach has been used extensively in forested ecosystems as a way of determining impacts of management activities on water yield. These studies have suggested that a minimum of 17 in of annual precipitation is needed in order to measure water yield as a result of vegetative manipulation. Because of this assumption, this approach has had limited use in rangeland settings. In 1994, the Camp Creek Paired Watershed Study was initiated to determine if juniper removal had any impact on hydrological processes. Two watersheds, Mays and Jensen (each approximately 260 acres in size) were identified for the purpose of calibrating, monitoring and analyzing the effects of juniper removal. The watersheds are located in the Camp Creek watershed, a tributary of the Crooked River, upper Deschutes River Basin. Continuous recording flumes, channel morphology, hillslope erosion, and a variety of geomorphological parameters were installed and analyzed to determine how alike and how different the two watersheds were from each other. In 2003, springs were developed to measure flow, weather stations were established onsite, and soil moisture and soil temperature probes were installed. Shallow wells were placed at the bottom of each watershed to monitor changes in near-surface groundwater.

Cell phone access, radio, and satellite telemetry were explored for ease of remote monitoring. Satellite

Fisher is an associate professor and department chair, Natural and Industrial Resources, Central Oregon Community College, Bend, OR 97701. Deboodt is an associate professor and extension agent, Oregon State University Extension Service, Crook County, Prineville, OR 97754. Buckhouse is professor, extension watershed specialist, Oregon State University Department of Rangeland Ecology and Management, Corvallis, OR 97331. Swanson is a rangeland specialist, Bureau of Land Management, Prineville District, Prineville, OR 97754.

telemetry and use of the Internet were selected because they allowed for continuous monitoring, sensor monitoring, and ease of data acquisition and analysis. The practicality of this approach makes long-term monitoring of landscapes feasible.

Keywords: paired watersheds, monitoring, geomorphology, western juniper, erosion processes.

Introduction

The purpose of this study was to use two similar watersheds in the western juniper zone to quantify and understand changes that are hypothesized to take place due to vegetation-type conversion. This project is a two-phased project. Phase one (1993–2003) included the instrumentation and calibration of the paired watersheds, whereas phase two encompasses the treatment and follow-up analyses. The first phase involved providing the watershed hydrology description and analysis of the two basins based on vegetation, soils, topography, geology, channel morphology, streamflow, local climate, and erosional processes. The calibration period, which was a continuation of the first phase, involved continued data collection for a period of approximately ten years (1994–2003), at which time one of the watersheds was treated and the other acted as a control based on the calibration period. Phase two began when Mays watershed was treated, providing for post-treatment data analysis.

Western juniper (*Juniperus occidentalis*) stands were modified in the treatment watershed in order to shift the vegetation structure from a juniper-dominated to a shrub/grass-dominated system. During the fall of 2005, all post-Euro-American established, western junipers were felled. Old growth (pre-European established trees) were left with the intent of mimicking natural conditions. Downed woody material should provide safe sites for grass seedling establishment as well as promote

the capture of sediment and minimize temperature extremes at the soil surface. This conversion of vegetation type should assist in the function of the water cycle by providing a more uniform and stable environment for capture, storage, and beneficial release of water (Buckhouse 1999). By converting the understory from bare ground to a grass and shrub cover, the site should retain moisture more readily and release the moisture into the system on a more stable and sustained basis.

During the calibration period, monitoring has quantified differences in streamflow quality and quantity. Differences in water quality were studied indirectly as a function of hillslope erosional processes and changes in channel geomorphology. The hillslope erosion was analyzed by evaluating the changes in vegetation versus bare soil composition, distribution and density, and soil status relative to increased or decreased erosion. Erosion and sedimentation were analyzed by studying changes in channel morphology in the primary channel of each watershed. Differences in streamflow quantity focused primarily on water yield within each watershed and comparisons between the two watersheds.

The vegetation conversion portion of this project focuses on the conversion of a western juniper overstory with relatively high percentages of bare ground interspaces to a grass/shrub system with minimal bare ground. One of the primary differences expected is a change in the distribution of biomass over the watersheds (Bates et al. 1999). Biomass distribution in western juniper-dominated systems tends to be elevated above the ground and moves toward patchiness of vegetative cover with larger concentrations of bare soil. The soil portion of phase two of the study will focus on whether or not the forces of erosion are stronger in the western juniper-dominated system (control) as compared to the treated system.

Project Location

The study area is located in central Oregon approximately 80 km southeast of Prineville and approximately 40 km northeast of Brothers along U.S. Highway 20.

Lessons Learned

Often the lessons learned in the setting up of a study are as important as the study itself. One of the key points that came into play during the setup phase of this study was "keep it simple." An example of "keeping it simple" was the use of sandbags as barriers against seepage at the front of the flume-approach. Although the sandbags are probably the most basic method for stabilizing this area (as compared to cold-patch asphalt, visquien plastic, metal shields, and geo-textile materials), they proved to be the most functional. Another example would be the sedimentation rods and cross-section plots used to determine erodible properties of soil scour and deposition on the hillslopes and in the main channels.

As technology improved over the life of the study, the focus also changed. During the early years of the study, the data loggers would breakdown causing large gaps in channel flow data collection (Deboodt 2008). During this time, the only way of knowing whether the devices were functioning was to be onsite to download the data and check. With the installation of the satellite communication technology, sensors could be checked weekly with the simple ease of logging onto the Internet and going to the website to see that data were being collected. Sensors not working could be identified and repairs scheduled with the supporting agencies. Even with this newfound capability, the necessity for regular field visits was never eliminated.

Flume Setup and Placement

The first step in the flume placement and selection was the reconnaissance of the area to be evaluated. This included selection of channel locations having low (2–4 percent) gradients, good access, and appropriate channel geometry. Flume placement was also critical, in that the study-area size was dependent on the flume location. Proper channel gradient is essential for maintaining accuracy of flume measurements (Grant 1992). For every 1 percent increase in slope greater than 2 percent gradient, there is a relative loss of accuracy of up to 5 percent in the stage measurement. Proper channel geometry was emphasized in order to allow for ease of flume placement and greater flume stability. Flumes and channels were matched according to depth and width, since poor fitting requires excess

soil removal and (or) fill and can make the flume vulnerable to washouts. Using sandbags allowed for increased flexibility of flume placement (Figure 1).

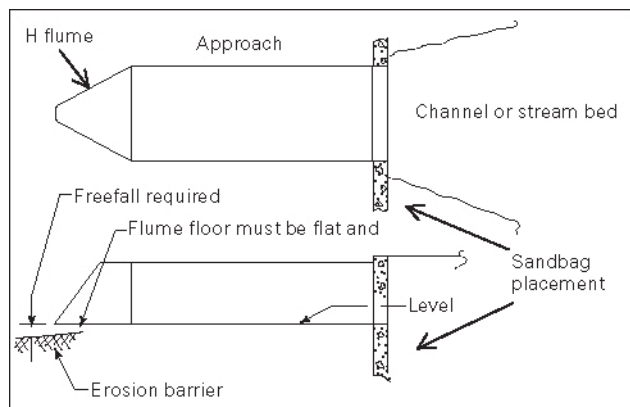

Figure 1. Flume schematic showing placement of sandbags.

Spring Flow

Throughout the pre-treatment period, two springs (one in each watershed) were identified. Flow had never been recorded and in conversations with the person who is both the landowner and Bureau of Land Management (BLM) permittee, the springs had been identified as seasonal at best. That is, each spring only flowed during spring snowmelt periods and provided no flows from mid-summer through the winter. In the fall of 2003, permission was received from the Prineville BLM District and the private landowner to improve the two springs and install spring boxes and pipe so that water could be collected and measured. A private contractor was hired to excavate and install the appropriate materials.

Well Development

In 1995, a series of shallow wells were placed at the bottom of each watershed near the flume (5 wells per watershed). Well depth varied between 0.9 and 8.2 m. The collection of well data was sporadic and incomplete but freestanding water in at least one of the deeper wells in each watershed was recorded sometime during the year.

In the fall of 2003, U.S. Department of Agriculture (USDA) Forest Service personnel from the Ochoco National Forest provided the expertise and drilling equipment to install 6 groundwater wells per

watershed (Deboodt 2008). A Simco© track portable drilling rig was equipped with a 5-in auger drill bit. Wells were drilled to a maximum potential depth of 8.2 m (27 ft). These wells have provided more complete data because of their placement and depth. Water is present in these multiple wells throughout the year.

Soil Moisture and Soil Temperature

According to Hibbert (1983) and Wilcox (1994) (as referenced in Deboodt 2008), soil moisture may often be the only measurable hydrologic response following vegetation conversion in semiarid watersheds. Although this was not the case in this study, the soil moisture data has proven to be very insightful as to the hydrologic function of these watersheds. In May 2005, soil moisture probes were placed in two locations within each watershed with each site containing 3 separate stations and each station containing 3 probes at different depths. At each station a trench was dug, exposing a 1-m profile of the soil. Holes were drilled in the trench wall at depths of 0.2, 0.45, and 0.76 m. The holes were drilled using a 16-mm drill bit, making a hole slightly larger than the probes. The hole was drilled slightly larger to allow for good probe-to-soil contact with minimal soil disturbance. Increased soil disturbance around the probe increases probe reading stabilization (Deboodt 2008). The soil moisture data provided insight on how the precipitation moves through the system seasonally, annually, and by each individual event.

Offsite Data Collection

Because the Paired Watershed Project is located approximately 65 mi southeast of Prineville, OR, it became evident that taking regularly timed data was critical in understanding the hydrological processes that were occurring at the site. Channel flow data were being recorded every 10 min, but there would be times that the data logger would quit working and data would be lost. Traveling to the site daily or weekly was not possible, so an effort was made to find a system that was compatible with the sensors installed. Remote access provided a means of accessing data and, when possible, provided a way to monitor the function of the equipment so that it could be determined, in real time, if sensors were working or not, which allowed for timely maintenance and repair.

Prior to choosing a system, several were reviewed that included cellular phone connections and radio, as well as combinations of radio, cellular phone, and satellite radio (Deboodt 2008). Due to the remoteness of the site and topography, there was no cellular signal near any of the monitoring sites. Radio access was limited and required licensing and locating sites for towers, as well as getting through the permitting process. A combination of short distance radio (monitoring site to ridge top) and cellular phone was also evaluated. Vegetation (trees) limited signal quality, and the cellular phone was limited to analog technology. Cellular phone companies in central Oregon at the time were abandoning analog technology in favor of digital. Working with Automata, Inc., satellite radios provided the solution. In 2004, automated weather stations were installed in both watersheds.

Each weather station is powered by a 12-volt battery that is continuously charged by onsite solar panels. The weather stations were constructed to allow for easy maintenance of all of the components. The tower was constructed with a pivoting point that allows for ease in lowering the top to the ground for access and maintenance of the elevated sensors (Deboodt 2008). The only requirement of this system was an unobstructed view of the sky so that the radios could communicate with the orbiting satellites (Automata, Inc. 2005). The satellite radio allowed access to all sensors daily, each on its own schedule. Satellite radios require no repeaters and each radio was separate and transmitted data through the satellite to a data server. Data were accessed through the Internet website <http://ifpnet.com> (Figure 2).

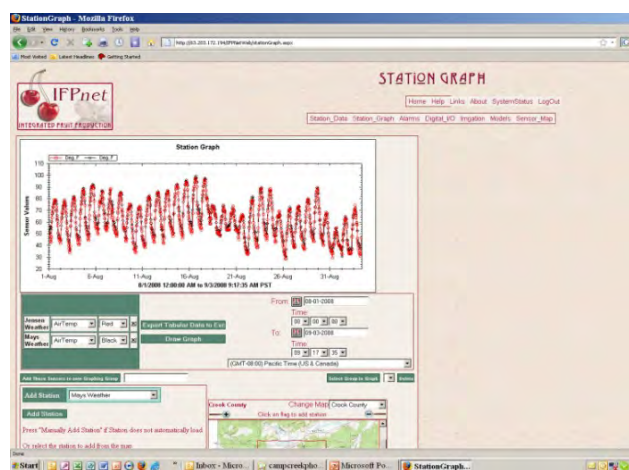

Figure 2. Webpage showing satellite generated data.

Data are currently accessible via the Internet 24 hrs a day. If there is a break in a line or a problem with a sensor or batteries, the system red flags the site, warning that there is a problem. This is a much improved approach compared with showing up onsite every other month to find that the batteries had died or a sensor had been disconnected sometime during the prior two months.

Conclusion

The intent at the beginning of this project was to keep it simple and applicable yet plan for the future. Planning for the future required researching the latest technological opportunities and evaluating their place in this type of study. The latest technology soon became outdated but still provided a firm foundation. As technology became more accessible and practical, it made sense to bring it onboard and broaden the opportunities of the project. The installment of the weather stations and associated sensors has made a dramatic difference in the month-to-month management of the project.

Acknowledgments

The author appreciates the reviews of Dr. Tim Deboodt and Peggy Fisher.

References

- Automata, Inc. 2005. Service Manual. Automata Inc.
- Bates, J., R. Miller, and T. Svejcar. 1999. Plant succession in cut juniper woodlands: 1991–1998. In Range Field Day 1999: Progress Report Juniper Woodlands: History, Ecology, and Management. pp. 30–43. Oregon State University, Eastern Oregon Agricultural Research Center, Special Report 1002, Corvallis, OR.
- Buckhouse, J.C. 1999. Juniper and watersheds. In Range Field Day 1999: Progress Report Juniper Woodlands: History, Ecology, and Management. pp. 25–28. Oregon State University, Eastern Oregon Agricultural Research Center, Special Report 1002, Corvallis, OR.
- Deboodt, T.L. 2008. Watershed Response to Western Juniper Control. Oregon State University. Ph.D. dissertation. Corvallis, OR. 156 p.
- Grant, D.M. 1992. Isco Open Channel Flow Measurement Handbook (3rd ed.). Isco Inc., Lincoln, NE.

Hydrologic Instrumentation and Data Collection in Wyoming

Ginger B. Paige, Scott N. Miller, Thijs J. Kelleners, Stephen T. Gray

Abstract

Wyoming is currently expanding and improving its hydrologic instrumentation and data collection network by installing new instrumentation in high alpine watersheds, expanding collection sites for soil moisture and precipitation data, and augmenting stream and meteorological collections across the state. The alpine watersheds are being instrumented in a nested network of meteorological stations, precipitation and snow gauges, soil moisture measurement sites, and runoff gauges to quantify the origins, fate, and transport of water. Additional instrumentation includes dendrometers and sediment samplers. In a complementary project, 18 soil moisture monitoring sites are distributed across the state in grasslands and shrublands. Installations are arranged in a shallow profile of 3 soil moisture probes and a tipping bucket rain gauge. In addition, runoff and meteorological sites are being installed in key basins around the state. These efforts are intended to (1) provide more detailed hydrologic data to better estimate parameters of watershed models; (2) improve drought forecasting and flood prediction; (3) increase the accuracy of water availability predictions in key basins; and (4) improve dissemination of hydrologic information across the state. Collaborators are the U.S. Forest Service, National Weather Service, U.S. Geological Survey, Wyoming Water Development Commission, and Wyoming Department of Agriculture.

Keywords: drought, soil moisture, watershed hydrology

Paige, Miller, and Kelleners are faculty at the University of Wyoming, Department of Renewable Resources, 1000 E. University Ave., Laramie, WY 82071. Gray is faculty at the University of Wyoming, Water Resources Data System, 1000 E. University Ave., Laramie, WY 82071. Email: gpaige@uwyo.edu; snmiller@uwyo.edu; tkellene@uwyo.edu; sgray8@uwyo.edu.

Introduction

Water and natural resource managers in semiarid states of the Intermountain West are challenged to quantify and allocate scarce water resources. Many western states are faced with increased demands on their water resources coupled with changing climate and diminished water supply. Wyoming is a semiarid state (average annual precipitation is 16.4 in), ranking the 5th most arid state in the United States. Though a headwater state, over 70 percent of the state receives less than 12 in of precipitation annually. Most of Wyoming's water resources are derived from high elevation (>10,000 ft) snow pack and associated spring runoff; its mountains receive more than 36 in of precipitation—predominately as snow.

Wyoming, as much of the Intermountain West, is often subjected to periods of drought. Additionally challenging for hydrologists is determining how hydrologic and ecological systems will respond to ongoing climate change. During the past 100 years of instrumented record, Wyoming has experienced at least four significant drought periods, most recently from 2000 to 2008. Other significant periods of drought have been revealed using proxy data such as tree ring reconstruction (Woodhouse et al. 2002, Gray et al. 2004). The distribution, timing, and severity of the droughts have varied greatly in Wyoming. The extent, severity, and duration of droughts are critical data in a state where 70 percent of the land area is grazed by domestic livestock and wildlife. However, droughts are difficult to identify and predict, and management to accommodate periods of prolonged drought is further complicated by the uncertainty of climate change.

Researchers are currently expanding and improving hydrologic instrumentation and data collection across Wyoming to enhance our ability to record and respond to fluctuating water availability and demands. The objectives in expanding these

monitoring networks are to provide: (1) detailed hydrologic data for parameterizing watershed models; (2) improved drought and flood forecasting; (3) increased accuracy of predicted water availability in key basins; and (4) more precise hydrologic information for dissemination to Wyoming residents. Efforts are targeting rangeland soil moisture, high alpine watersheds, and additional stream and meteorological stations.

Soil Moisture Instrumentation

Rangeland productivity is affected by variations in the amount and timing of precipitation and the ability of the soil to hold water. A network of soil moisture sites (18 across the state) was established in 2003–05 to determine local relationships between spring soil moisture content and forage production.

Each site was initially instrumented with Campbell Scientific CS625 soil moisture probes installed vertically at depths of 0–30, 30–60, and 60–90 cm. At the time of installation, no site specific soil characteristics were measured. Starting in 2007, these soil moisture sites have been updated by performing site-specific calibrations to increase the accuracy of the data. Vertical installation of the probes results in an average soil moisture reading for the depth of the probe. Horizontal positioning of probes is preferred for accurate estimation of soil moisture content at a given depth. During the updating process, any replaced sensors were installed horizontally in the soil at depths of 15, 45, and 75 cm. All soil water monitoring sites have recently been fitted with tipping bucket rain gauges (Texas Electronics TE525WS-L), weather-proof enclosures, and solar panel power sources (Figure 1). By measuring both the soil water dynamics and precipitation at the same location, we can directly link the site's moisture conditions to local rangeland productivity. Rangeland production is currently measured on most of the sites using annual clippings of fenced enclosures.

Soil physical characterizations such as bulk density and particle size analysis have been determined for all sites. Soils material was collected from each site and soil-specific sensor calibrations completed by wetting dry soil to a range of soil water contents and measuring the response from the CS625 probe.



Figure 1. Newly instrumented soil moisture and rainfall recording site near Meeteetse, WY.

After each wetting, the soil was carefully packed in a bucket, for a soil moisture probe reading. Soil moisture readings were taken with the CS625, with a Campbell Scientific TDR100 probe, and with a Stevens Water Hydra probe for comparison. The sensor-observed soil permittivity (i.e., the energy storage due to polarization) was then plotted against soil water content readings from the three sensors to obtain calibrations (results for a site near Meeteetse, WY, are shown in Figure 2). The soil water content versus permittivity relationship developed by Topp et al. (1980) is shown for comparison. The soil moisture relationships for the CS625 probes for each site were programmed into individual site datalogger programs. The newly developed calibrations will also be used to “back calculate” existing soil moisture measurement datasets that used a generic calibration.

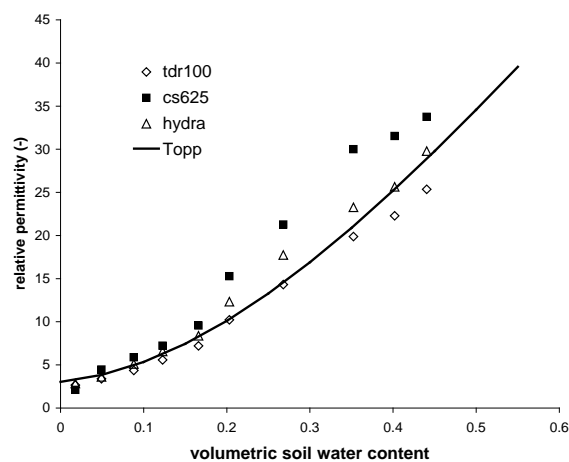

Figure 2. Laboratory calibration of repacked soil from the top 30 cm of soil at the Meeteetsee soil moisture monitoring site.

There is a recognized need for spatially distributed soil moisture content data, nationwide (Robinson et al. 2008). Since 1991, the National Water and Climate Center (U.S. Department of Agriculture–National Resources Conservation Service) has maintained a national network of 129 SCAN (Soil Climate Analysis Network) sites (Schaefer et al. 2007). The network of geographically dispersed soil moisture monitoring sites, coupled with precipitation gauges across the state, is of great value for (1) increasing our knowledge of the relationships between rainfall, soil moisture dynamics, and forage production, and (2) developing a drought risk prediction tool.

Nested Alpine Watershed

The majority of Wyoming’s annual water supply comes from high-elevation alpine snow pack. Insights into the amount and timing of snowmelt are critical for managing the State’s water resources and downstream allocations to neighboring states. To increase our understanding of high alpine watershed processes, we are installing a hydrologic instrumentation network in Lower Libby Creek Watershed in the Snowy Range of the Medicine Bow Mountains in southeast Wyoming. The Libby Creek Watershed was instrumented and ecological and hydrologic data were collected in the watershed from the 1960s to the 1990s. Re-instrumentation of sections of this large watershed will allow us to draw comparisons with “historic” datasets. In addition, more than 1.5 million acres of forest in northern Colorado and southern Wyoming are affected by the Mountain Pine Bark Beetle epidemic, which was triggered by the extended drought in the late 1990s and early 2000s. A large portion of the Snowy Range has experienced die-off due to the infestation, and the extent of the die-off is expected to increase over the next several years (<http://www.fs.fed.us/r2/mbr/resources/BarkBeetles/index.shtml>). It anticipated that hydrologic patterns and the water balance will be altered as a result of the Pine Bark Beetle infestation. Positioning our instrumentation in an area experiencing die-off from the infestation will allow us to track changes to the hydrologic cycle over time.

The hydrologic and meteorologic instrumentation are being installed in a nested watershed framework in the lower Libby Creek Watershed (Figure 3). There is a single order watershed, draining

approximately 122 ha, that intersects Libby Creek, which drains an area over 2,200 ha. The instrumentation network comprises a meteorological station, precipitation and snow gauges, soil moisture measurement sites, submersible pressure transducers (to measure runoff), dendrometers (to measure tree stem growth), and stable isotope and sediment samplers. The network is expected to expand over time as resources become available.

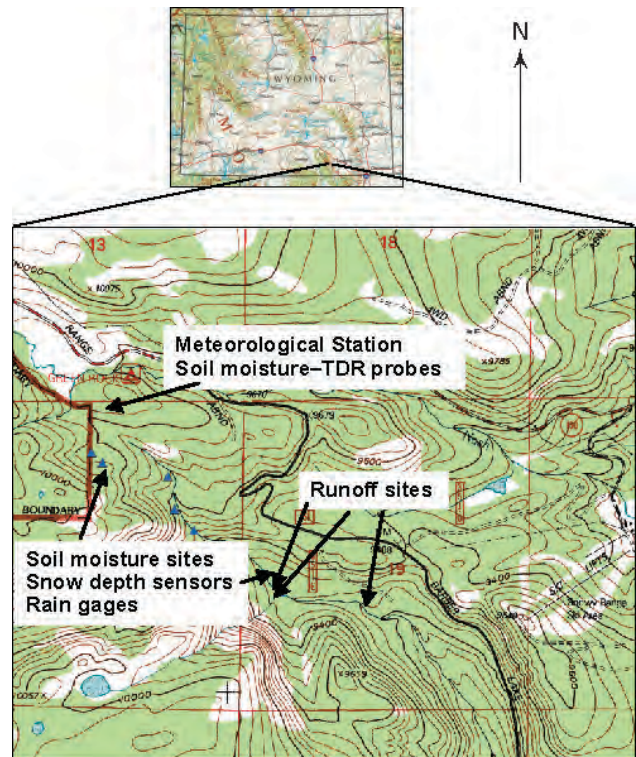

Figure 3. Instrumentation sites in the Lower Libby Creek Watershed in the Snowy Range, southeast Wyoming.

The long-term effort will increase our understanding of surface hydrologic processes in high alpine watersheds and provide a valuable dataset for improved watershed model parameterization for snow-dominated systems. The nested watersheds also serve as an outdoor classroom for students at the University of Wyoming. As part of an upper-level and graduate student course in watershed hydrology, students are introduced to critical field equipment through installation, maintenance, and data collection in a research watershed. An additional objective of this project is to quantify impacts of the Mountain Pine Bark Beetle infestation on the surface water hydrologic processes of a high alpine system.

The lower Libby Creek Watershed is a collaborative study site that engages researchers from several departments at University of Wyoming, the Wyoming State Climatologist Office, and the U.S. Forest Service. The watershed is located adjacent to and downstream from the U.S. Forest Service Glacial Lakes Ecosystem Experiments Site (GLEES; <http://www.fs.fed.us/rm/landscapes/Locations/Glees/GLEES.shtml>). GLEES is a high elevation research site intended to determine the effects of atmospheric deposition and climate change on alpine and subalpine aquatic and terrestrial ecosystems and the upper treeline ecotone. Concomitantly with the intensive instrumentation of the Libby Creek watershed, additional runoff and meteorologic instrumentation is being installed in selected locations around the state.

Summary

Wyoming, along with the rest of the semiarid Intermountain West, is challenged to adapt to periodic drought conditions while planning for future uncertainties in water budgets and water supplies associated with climate change. One potentially significant long-term effect of a warmer climate in Wyoming is decreased water availability, necessitating changes in livestock production and other agricultural practices. In the face of growing uncertainty about the rainfall and runoff cycle, water resource professionals in Wyoming are expanding our hydrologic data network in a unified effort to (1) improve our knowledge of our current water supply, and (2) improve our ability to identify droughts and water supply deficiencies across the state. Neither of these tasks is simple, but each may be more manageable with timely and detailed data.

Acknowledgments

The authors would like to thank Dr. Ann Hild and Dr. Jay Norton for reviewing the manuscript.

References

Gray, S.T., C.L. Fastie, S.T. Jackson, J.L. Betancourt. 2004. [Tree-ring-based reconstruction of precipitation in the Bighorn Basin, Wyoming, since 1260 A.D.](#) *Journal of Climate* 17:3,855–3,865.

Robinson, D.A., C.S. Campbell, J.W. Hopmans, B.K. Hornbuckle, S.B. Jones, R. Knight, F. Ogden, J. Selker, and O. Wendroth. 2008. Soil moisture

measurement for ecological and hydrological watershed-scale observatories: A review. *Vadose Zone Journal* 7:358–389.

Schaefer, G.L., M.H. Cosh, and T.J. Jackson. 2007. The USDA National Resources Conservation Service, soil climate analysis network (SCAN). *Journal of Atmospheric and Oceanic Technology* 24:2,073–2,077.

Topp, G.C., J.L. Davis, and A.P. Annan. 1980. Electromagnetic determination of soil water content: Measurements in coaxial transmission lines. *Water Resources Research* 16:574–582.

Woodhouse, C.A., J.J. Lukas, and P.M. Brown. 2002. [Drought in the Western Great Plains, 1845–56](#). *Bulletin of the American Meteorological Society* 83(10): 1,485–1,493.

Advanced Spatial and Temporal Rainfall Analyses for Use in Watershed Models

Douglas Hultstrand, Tye Parzybok, Ed Tomlinson, Bill Kappel

Abstract

Accurate estimation of the spatial and temporal distribution of rainfall is a crucial input parameter into a surface water model for hydrologic model calibration and validation. Typically, the number of rain gauges used to monitor rainfall is generally inadequate to resolve the spatial and temporal distributions of rainfall over the watershed. Techniques have been developed to calibrate NEXRAD radar data with rain gauge data to improve the accuracy of radar rainfall estimates, and produce high spatial and temporal resolution rainfall information for use in runoff model calibration and validation (Parzybok et al. 2008).

The Storm Precipitation Analysis System (SPAS) precipitation-radar algorithms were used along with National Weather Service default NEXRAD coefficients and inverse-distance weighting (IDW) for estimating the spatial and temporal rainfall distribution over Alsea watershed in northwestern Oregon. The three precipitation estimates were used as input into a hydrologic model to quantify the accuracy of precipitation inputs as compared to the hydrologic model output. Depth-area-duration (DAD) analysis was performed to determine the maximum amounts of precipitation within various durations over areas of various sizes.

Keywords: gauge adjusted radar, hydrology, depth-area-duration (DAD), spatial precipitation

Hultstrand is a hydrometeorologist, Metstat, Inc, Windsor, CO, 80550, and a Ph.D. candidate in Watershed Science, Colorado State University, CO, 80523. Parzybok is chief meteorologist and president of Metstat, Inc, Windsor, CO, 80550. Tomlinson is chief meteorologist and president of Applied Weather Associates, Monument, CO 80132. Kappel is a meteorologist and vice president of Applied Weather Associates, Monument, CO, 80132.

Introduction

Radar has been in use since the 1960s to estimate precipitation depth. In general, most current radar-derived precipitation methods rely on a relationship between radar reflectivity and precipitation rate:

$$Z = aR^b \quad (1)$$

where Z is the radar reflectivity (dBZ), R is the precipitation rate, a is the “multiplicative coefficient,” and b is the “power coefficient”. Both a and b are directly related to the drop size distribution (DSD) and the drop number distribution (DND) within a cloud (Martner et al. 2005).

The National Weather Service (NWS) uses this relationship to estimate precipitation through the use of their network of WSR-88D radars (NEXRAD) located across the United States. A default Z-R relationship of $Z=300R^{1.4}$ is the primary algorithm used throughout the country, but it often produces inaccurate results (Hunter 2008).

Study Site

The portion of the Alsea watershed above Tidewater, OR, is located within the Siuslaw National Forest, a diverse forest encompassing 630,000 acres of varying ecosystems. Alsea watershed is 331 mi² in size, ranges in elevation from 56 to 4,095 ft, and has a mean basin elevation of 1,050 ft (Figure 1). Average annual precipitation is approximately 81.40”, with 12.68” falling in November (PRISM Group 2008). The 24-hr 2-yr precipitation event is 4.93” and the 24-hr 100-yr precipitation event is 8.78” (Miller et al. 1973).

The storm event analyzed for this paper is a 48-hr window during 6–8 November 2006. During this window, the Alsea watershed received an average of 5.55” of rainfall in a 48-hr period, an average of 4.57” in a 24-hr period and a maximum point rainfall of 6.80”

in a 24-hr period. The maximum 24-hr precipitation within the Alsea watershed for this storm event is between the 2-yr and 100-yr 24-hr precipitation event (Miller et al. 1973).

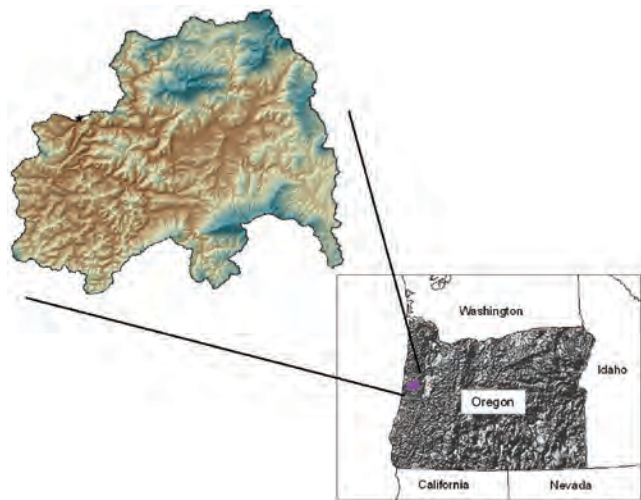

Figure 1. Study site map showing location of the Alsea watershed. Star indicates basin outlet.

Methods

The Storm Precipitation Analysis System (SPAS) is a state-of-the-science hydrometeorological tool used to characterize the temporal and spatial details of precipitation events. SPAS was used to evaluate the accuracy of precipitation input into a hydrologic model using three precipitation inputs: Optimized, Default, and Inverse-distance weighting (IDW).

Optimized

SPAS utilizes an iterative procedure for optimizing the Z-R relationship for each hour of the analysis period. The process begins by determining if sufficient observed hourly rainfall data are available to compute a reliable Z-R. If there is insufficient observed rainfall data available, then the Z-R relationship will either adopt the previous hours' Z-R relationship (if available) or apply the default $Z=300R^{1.4}$ algorithm. If sufficient rainfall data are available, however, it is related to the hourly sum of NEXRAD reflectivity. A best-fit power function through the data points is computed. The resulting multiplicative coefficient (a), power coefficient (b), and maximum predicted rainfall are subjected to several tests to determine if the Z-R relationship is acceptable. Once a mathematically optimized hourly Z-R relationship is determined, it is

applied to the scan level Z-grid to compute an initial rainfall rate (mm/hr) at each grid cell within the extent of radar data.

Spatial differences in the Z-R relationship exist across the radar domain because of differences in DSD and DND. To account for these differences, SPAS computes residuals, the difference between the initial rainfall analysis (from the Z-R equation), and the actual observed rainfall (observed–initial analysis), for each gauging station. To down-weight anomalous residuals and promote a spatially smooth pattern, the residuals are smoothed using a spatial filter. A final hourly rainfall grid is created by adding the adjusted scan grids.

Default

SPAS uses a non-iterative procedure for the Z-R relationship, $Z=300R^{1.4}$ at the scan level, and applies no bias correction.

Inverse-distance weighting

SPAS uses hourly data to temporally distribute daily data into hourly data. The hourly and daily/hourly precipitation data are spatially and temporally distributed solely on the gauge data using an IDW algorithm:

$$\hat{z}(x_0) = \frac{\sum_{i=1}^n \frac{z(x_i)}{d_i^p}}{\sum_{i=1}^n \frac{1}{d_i^p}} \quad (2)$$

where $\hat{z}(x_0)$ is the interpolated value, n is the number of sample points, $z(x_i)$ is the i th data value, d_i denotes the separation distance between the interpolated value and data value, and P denotes the weighting power.

Depth-area-duration

A depth-area-duration (DAD) analysis was calculated to provide a multi-dimensional characterization of the storm. It is a powerful tool for comparing the rainfall associated with different storm events over various spatial and temporal scales not possible with point precipitation amounts only.

Hydrologic modeling

The Hydrologic Engineering Center (HEC) U.S. Army Corps of Engineers Hydrologic Modeling System (HMS) was used to model basin streamflow. HEC-HMS used the gridded rainfall estimates for input; the model was setup and run as basin average rainfall versus distributed rainfall because of time constraints.

Results

Each of the three SPAS runs generated considerably different spatial and temporal patterns associated with the hourly and total storm grids.

Optimized rainfall

The SPAS Optimized rainfall created a pattern that is true to the spatial and temporal characteristics of the observed rain gauges. The maximum basin precipitation is 8.30" and has a basin average precipitation of 5.55" (Figure 2).

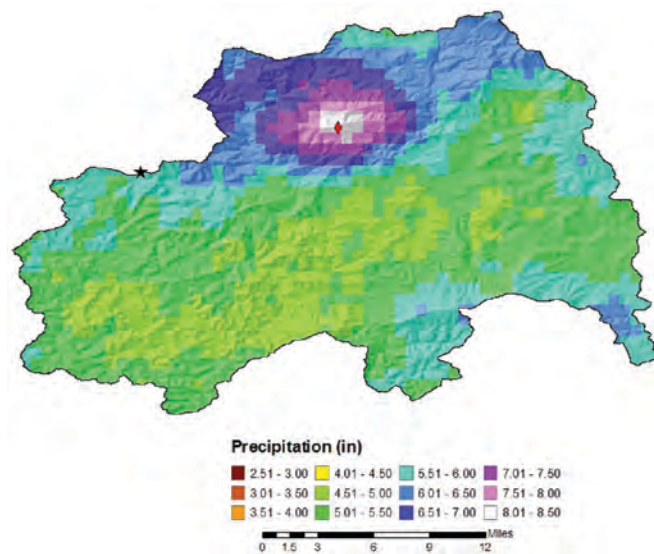

Figure 2. Optimized radar reconstruction for the 6–8 November 2006 storm event. Maximum basin precipitation is 8.30" (red diamond), average basin precipitation is 5.55", minimum basin precipitation is 4.64", and precipitation at the basin outlet is 5.81".

Default rainfall

The SPAS Default rainfall created a pattern that is not true to the spatial and temporal characteristics of the observed rain gauges. The maximum basin precipitation is 6.16" (location of Optimized grid) and has a basin average precipitation of 4.54" (Figure 3).

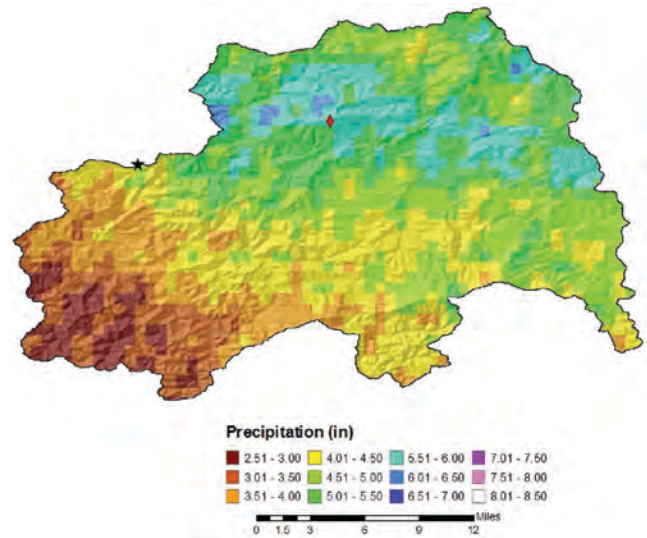

Figure 3. Default radar reconstruction for the 6–8 November 2006 storm event. Maximum basin precipitation is 6.16" (red diamond), average basin precipitation is 4.54", minimum basin precipitation is 2.51", and precipitation at the basin outlet is 4.64".

Inverse-distance weighting rainfall

The SPAS IDW rainfall created a pattern that is true to the spatial and temporal characteristics of the observed rain gauges. The spatial pattern between rain gauges is not accurate and conforms to a bulls-eye pattern. The maximum basin precipitation is 7.16" (location of Optimized grid) and has a basin average precipitation of 5.42" (Figure 4).

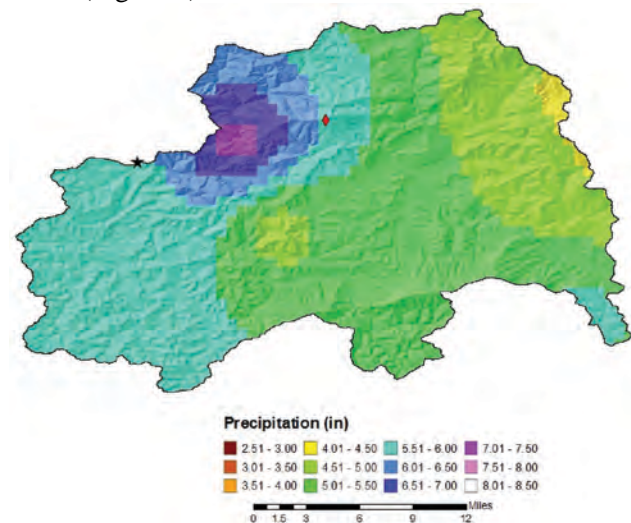

Figure 4. IDW for the 6–8 November 2006 storm event. Maximum basin precipitation is 7.16" (red diamond), average basin precipitation is 5.42", minimum basin precipitation is 4.41", and precipitation at the basin outlet is 5.83".

Mass curves

Mass curves, plots of the temporal distribution and the magnitude of precipitation, were created at three locations for each of the three SPAS runs: maximum precipitation point (from the optimized run), the basin outlet, and the basin average precipitation.

The SPAS Optimized mass curves have a large difference in the magnitude; the overall timing is in good agreement. The maximum basin precipitation was 8.30", the basin outlet was 5.80", and the average basin 5.55" (Figure 5).

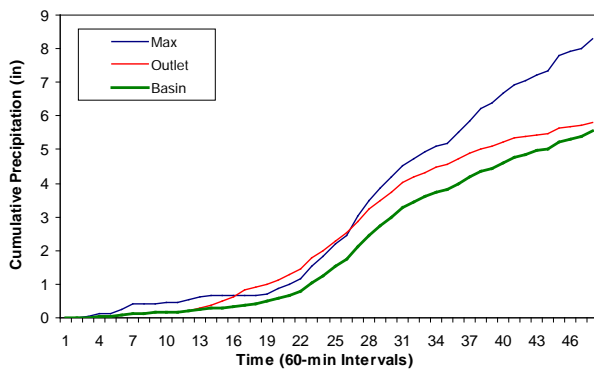

Figure 5. Optimized radar reconstruction mass curves. Maximum basin precipitation is 8.30" (blue), basin outlet precipitation is 5.80" (red), and basin average precipitation is 5.55" (green).

The SPAS Default mass curves exhibit less difference in the magnitude; the overall timing is in good agreement. The maximum basin precipitation was 5.70", the basin outlet was 4.64", and the average basin 4.54" (Figure 6).

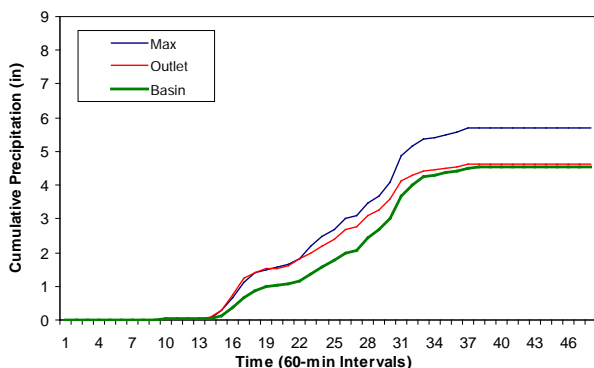

Figure 6. Default radar reconstruction mass curves. Maximum precipitation (based on optimized basin location, red diamond) is 5.70" (blue), basin outlet precipitation is 4.64" (red), and basin average precipitation is 4.54" (green).

The SPAS IDW mass curves show little difference in the magnitude and the overall timing is in good agreement. The maximum basin precipitation was 5.95", the basin outlet was 5.83", and the average basin 5.42" (Figure 7).

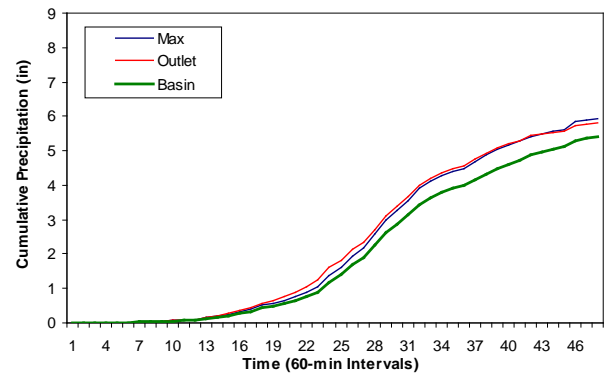

Figure 7. IDW mass curves. Maximum precipitation (based on optimized basin location, red diamond) is 5.95" (blue), basin outlet precipitation is 5.83" (red), and basin average precipitation is 5.42" (green).

Observed versus predicted precipitation

The overall fits between the total storm observed precipitation and predicted total storm precipitation at gauge locations were used to assess the overall fit of the gridded rainfall for each of the three SPAS runs.

The SPAS Optimized total storm rainfall versus the observed rainfall correlation is extremely high; the coefficient of determination is 0.923 (Figure 8; red line is the correlation and the black line is a 1-1 fit). The maximum observed precipitation (not within the watershed) is predicted almost exactly.

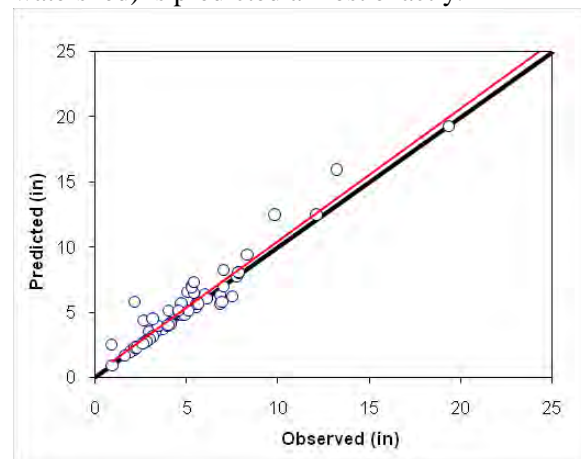

Figure 8. Optimized radar reconstruction observed precipitation versus radar reconstruction precipitation. Coefficient of determination is 0.923.

The SPAS Default total storm rainfall versus the observed rainfall correlation is extremely poor; the coefficient of determination is 0.347 (Figure 9; red line is the correlation and the black line is a 1-1 fit). The Default run almost always underestimated the observed precipitation.

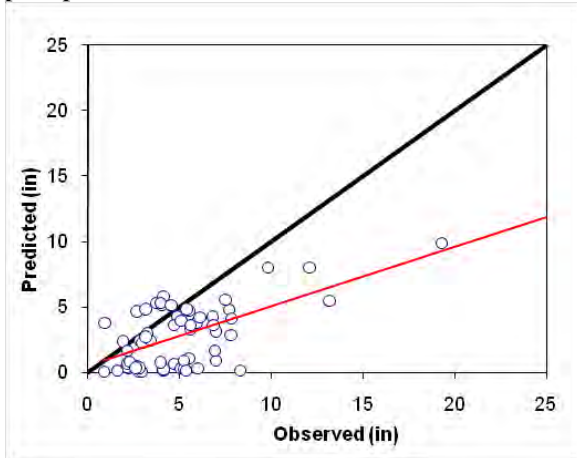

Figure 9. Default radar reconstruction observed precipitation versus radar reconstruction precipitation. Coefficient of determination is 0.347.

The SPAS IDW total storm rainfall versus the observed rainfall correlation is extremely high; the coefficient of determination is 0.971 (Figure 10; red line is the correlation and the black line is a 1-1 fit). The IDW run has a great fit due to the nature of IDW, which is an exact interpolator of the point but is not representative between gauges.

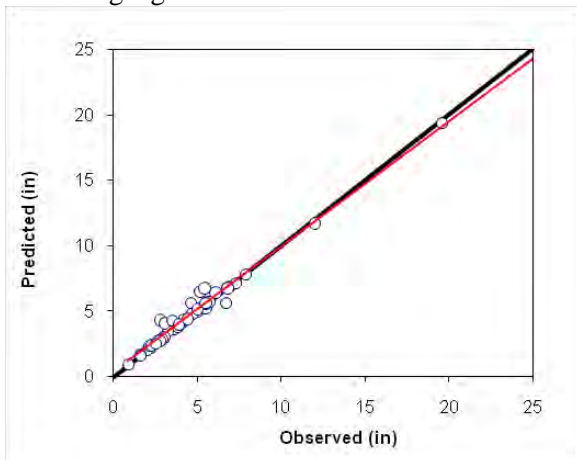

Figure 10. IDW observed precipitation versus IDW precipitation. Coefficient of determination is 0.971.

Depth-area-duration results

A DAD analysis was calculated to provide a multi-dimensional characterization of the storm within the

watershed. The overall DAD suggests that the shorter duration precipitation was almost uniform across the watershed, where as the longer (>6 hrs) duration precipitation was not uniform across the watershed.

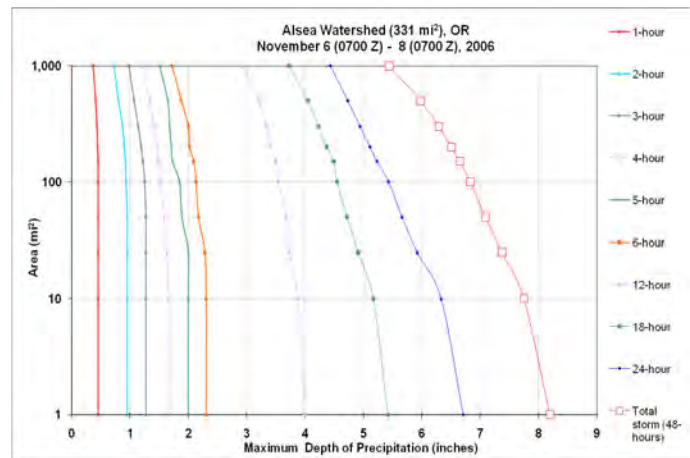

Figure 11. Optimized radar reconstruction depth-area-duration (DAD) analysis for the Alesa watershed 6–8 November 2006 storm event.

Hydrologic modeling

The observed cumulative streamflow for the Alesa watershed is 2.23”, the SPAS Optimized cumulative streamflow is 2.18”, the SPAS Default cumulative streamflow is 2.12”, and the SPAS IDW cumulative streamflow is 2.14”. The incremental precipitation (SPAS Optimized data) and the cumulative streamflow for each three SPAS runs vary in magnitude, but the overall timing has good agreement (Figure 12).

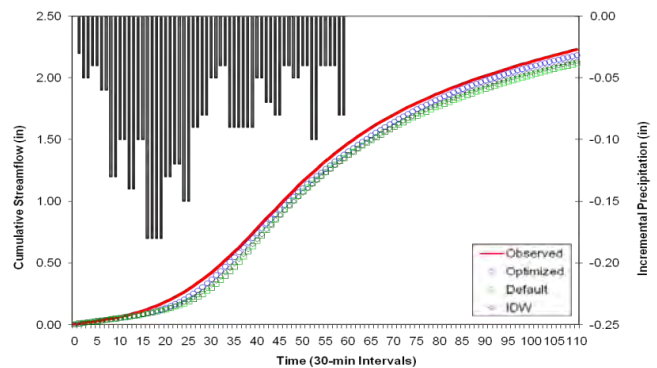

Figure 12. Cumulative streamflow modeled with the optimized (blue), default (green), and IDW (black) average basin hourly precipitation grids. Optimized precipitation is shown (grey).

The overall fits between the observed cumulative streamflow and the predicted cumulative streamflow were used to assess the relative error of the gridded rainfall for each of the three SPAS runs. All three basin average precipitation inputs generate extremely high relationships. The SPAS Optimized cumulative streamflow correlation is 0.976, the SPAS Default cumulative streamflow correlation is 0.954, and the SPAS IDW cumulative streamflow correlation is 0.973 (Figure 13).

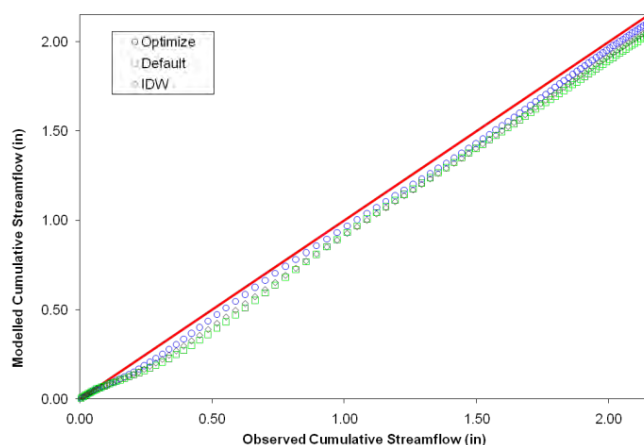

Figure 13. Observed cumulative streamflow (red) versus modeled cumulative streamflow for optimized (blue, $r^2 = 0.976$), default (green, $r^2 = 0.954$), and IDW (black, $r^2 = 0.973$) precipitation.

Conclusions

The Optimized SPAS run was able to maintain the spatial and temporal distribution of rainfall, whereas the SPAS Default and IDW were not able to maintain either the spatial or the temporal rainfall distribution.

These results suggest that the SPAS Optimized gridded precipitation, basin average, input into HEC-HMS produced better cumulative streamflow results when compared to the SPAS Default and IDW basin average precipitation inputs.

The integration of radar rainfall data into hydrologic models allows engineers and hydrologists to more accurately characterize rainfall events. The Optimized SPAS run generated the best hydrologic model results, as a result of a more accurate placement of rain at the right time.

Future work will entail the use of a spatial distributed hydrologic model, where each pixel within the basin will be used to characterize the relationship and processes between rainfall and streamflow. This model will characterize intrabasin variations in rainfall more accurately than one using basin-average rainfall estimates.

References

- Hunter, S.M. 2008. WSR-88D Radar rainfall estimation: Capabilities, limitations and potential improvements. National Weather Service Forecast Office, Morristown, TN. [online] URL: <http://www.srh.noaa.gov/mrx/research/precip/precip.php>. Accessed October 2008.
- Martner, B.E., V. Dubovskiy, and S.Y. Matrosov. 2005. Z-R Relations from raindrop disdrometers: Sensitivity to regression methods and DSD data refinements. In The 32nd Radar Meteorology Conference, Albuquerque, NM, 22–29 October 2005, Paper no. P14R.4. American Meteorological Society.
- Miller, J.F., R.H. Frederick, and R.J. Tracey. 1973. Precipitation-frequency atlas of the western United States, v. 10: Oregon. U.S. Department of Commerce, National Oceanic and Atmospheric Administration, National Weather Service, Atlas 2.
- Parzybok, T.W., D.M. Hultstrand, E.M. Tomlinson, and W.D. Kappel. 2008. High-resolution storm rainfall analysis for use in hydrologic modeling: Storm precipitation analysis system (SPAS) and NEXRAD weather radar. In Proceedings of HydroVision 2008, Sacramento, CA, 14–18 July 2008, Paper no. 226. PennWell Hydro Group, HCI Publications.
- PRISM Group, 2008. Prism Group [climate dataset resource]. PRISM Group, Oregon State University. [online] URL: <http://www.prismclimate.org>. Accessed 3 September 2008.

Primary Factors Affecting Water Quality and Quantity in Four Watersheds in Eastern Puerto Rico

Sheila F. Murphy, Robert F. Stallard

Abstract

As part of the U.S. Geological Survey (USGS) Water, Energy, and Biogeochemical Budgets (WEBB) program, four small watersheds in eastern Puerto Rico were monitored to identify and evaluate the effects of geology, landcover, atmospheric deposition, and other factors on stream water quality and quantity. Two catchments are located on coarse-grained granitic plutonic rocks, which weather to quartz- and clay-rich, sandy soils, and two are located on fine-grained volcanic rocks and volcanoclastic sediments, which weather to quartz-poor, fine-grained soils. These differing soil materials result in different hydrologic regimes. Soils on the granitic rocks have greater permeability than those developed on the volcanoclastic rocks, allowing more water infiltration and potentially greater landslide erosion rates. For each bedrock type, one catchment was covered with mature rainforest, and the other catchment was affected by agricultural practices typical of eastern Puerto Rico. These practices led to the erosion of much of the original surface soil in the agricultural watersheds, which introduced large quantities of sediment to stream channels. The agricultural watersheds are undergoing natural reforestation, like much of Puerto Rico. Eastern Puerto Rico receives large atmospheric inputs of marine salts, pollutants from the Northern Hemisphere, and Saharan Desert dust. Marine salts contribute over 80 percent of the ionic charge in precipitation, with peak inputs in January. Intense storms, mostly hurricanes, are associated with exceptionally high chloride concentrations in stream waters. Temperate pollution contributes nitrate, ammonia, and sulfate, with maximum inputs during northern cold fronts in January,

April, and May. Pollution inputs have increased through time. Desert dust peaks in June and July, during times of maximum dust transport from the Saharan Desert across the Atlantic Ocean.

Keywords: Puerto Rico, Luquillo, landcover change, atmospheric deposition, hurricanes

Introduction

The U.S. Geological Survey (USGS) Water, Energy, and Biogeochemical Budgets (WEBB) program strives to understand the processes controlling fluxes of water, energy, and elements over a range of temporal and spatial scales. The WEBB program includes five field sites across the United States (Colorado, Georgia, Puerto Rico, Vermont, and Wisconsin) that vary in landform, hydrology, climate, and ecology. The Puerto Rico WEBB site represents a montane, humid-tropical environment. Precipitation, runoff, and water chemistry were monitored by the USGS in four small (3.3–26 km²) watersheds (Icacos, Mameyes, Canóvanas, and Cayaguás) in eastern Puerto Rico from 1991 to 2005 (Figure 1). These data, in combination with data from the National Oceanic and Atmospheric Administration (NOAA) and the U.S. Department of Agriculture–Forest Service (USDA-FS), can be used to understand how landscape, vegetation, long-range atmospheric deposition, and people interact to affect water quantity and quality and erosion processes in the watersheds. A regional synthesis of riverine discharge and water quality cannot succeed without high-quality characterization, utilizing a geographic information system (GIS) approach, of the landscape in which the rivers are embedded. The present report summarizes our efforts at such a characterization.

Murphy and Stallard are hydrologists, both with the U.S. Geological Survey Water Resources Discipline, 3215 Marine St. Suite E127, Boulder, CO 80303. Email: sfmurphy@usgs.gov; stallard@usgs.gov.

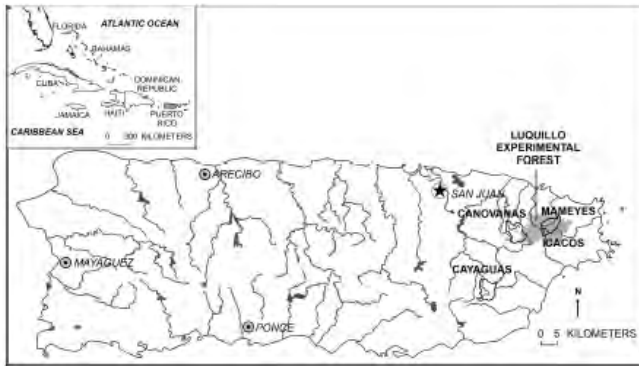

Figure 1. Location of Puerto Rico and study watersheds (outlined).

Geology and Weathering Processes

The island of Puerto Rico is part of the Antilles Island Arc, which was formed by volcanism and sedimentation typical of a plate boundary. The island consists of a core of igneous rocks surrounded by younger sedimentary rocks (Figure 2). The Mameyes and Canóvanas watersheds are primarily underlain by marine-deposited, quartz-poor volcanoclastic rock, while the Icacos and Cayaguás watersheds are underlain by granitic rocks. The volcanoclastic rocks weather to clay-rich, fine-grained soils, whereas the granitic rocks weather to quartz- and clay-rich, sandy soils. Soils on the granitic rocks have greater permeability than those over the volcanoclastic rocks, allowing more water infiltration (Simon et al. 1990). The clay-rich soils of the volcanoclastic rocks are more cohesive than the quartz-rich soils over granitic rocks and thus are more resistant to erosion. Our studies suggest that these differences lead to a seven-fold greater physical erosion rate in the granitic soils. Brown et al. (1995) showed that the Icacos watershed is eroding at near steady state, with coarse material being mobilized from deep in the profile

by landsliding. Thus, the high rates of physical erosion in the Icacos watershed do not reflect a recent acceleration of physical erosion. Chemical-erosion rates, in contrast, appear to be within a factor of two for all the different rock types and landcovers, and thus water chemistry of the rivers are not substantially different (R.F. Stallard, 2008, USGS, written commun.).

Landcover

Puerto Rico has undergone a rapid transformation in the past several centuries from pre-European conditions of relatively undisturbed forest, to intensive agriculture in the 19th and early 20th century, to an industrial economy since 1950. In the past 60 years, landcover of Puerto Rico has shifted from being almost entirely deforested to having forest covering about half of the island (Figure 3). Meanwhile, human population density of Puerto Rico has increased over threefold during the last century, resulting in one of the highest densities in the world. Accordingly, Puerto Rico may serve as a prototype for reforestation of tropical areas that are shifting from an agricultural to an industrial economy.

Two of the study watersheds are covered with mature rainforest (Icacos and Mameyes, Figure 1) and are within the Luquillo Experimental Forest (LEF), a forest preserve administered by the USDA-FS. Access to the LEF was historically very limited because of steep slopes, high annual rainfall, and designation as a reserve by the Spanish crown and later by the U.S. Government. Two watersheds (Cayaguás and Canóvanas) have been affected by agricultural activities typical of eastern Puerto Rico (pasture, coffee, tobacco, fruit crops), which led to the loss of much of the original surface layer of soil in these watersheds. Larsen and Santiago Román (2001) estimate that erosion in the Cayaguás watershed, which was intensely farmed for

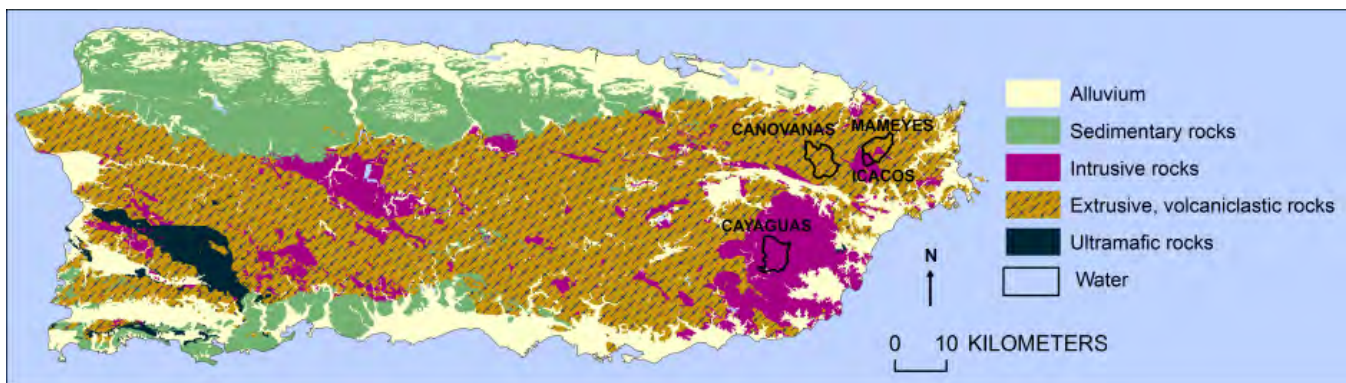

Figure 2. Geology of Puerto Rico and study watersheds (from Bawiec, 2001).

two centuries, lowered the mean surface elevation in the watershed by 660 mm and introduced massive amounts of sediment to river channels, where much of it was deposited as alluvium. This sediment continues to be remobilized during large storm events. The Cayaguás and Canóvanas watersheds have since undergone some degree of reforestation, which can change hydrology of watersheds by increasing evapotranspiration and decreasing streamflow (Jackson et al. 2005).

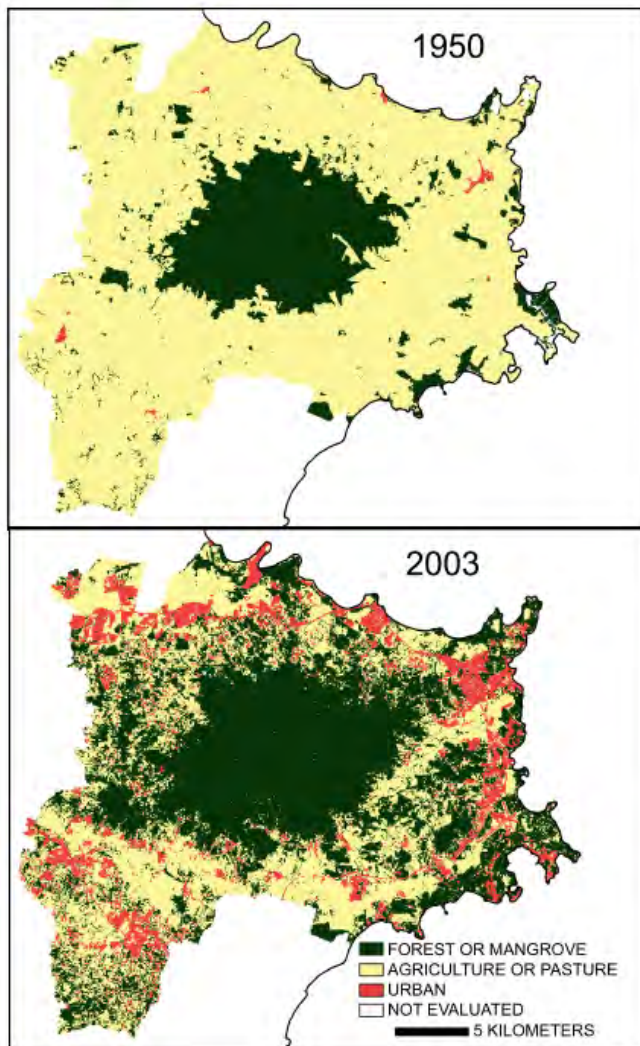

Figure 3. Landcover in northeastern Puerto Rico in 1950 and 2003 (W.F. Gould, 2008, USDA-FS, written commun.).

Hurricanes

Puerto Rico lies directly in the path of the easterly trade winds and receives as much as 70 percent of yearly rainfall from tropical disturbances imbedded in the trade winds, which are strongest from May through

December. Storms range from tropical waves to hurricanes. Major tropical disturbances affect the Caribbean about nine times a year. Hurricanes impact Puerto Rico about once every 10 years (Figure 4). The most recent hurricanes that caused substantial damage in eastern Puerto Rico were Hugo in 1989, which had winds over 200 km/hr, and Georges in 1998, with winds of 240 km/hr. Rainfall associated with Georges totaled 630 mm in the central mountains and triggered extensive flooding and debris flows (Larsen and Webb 2009).

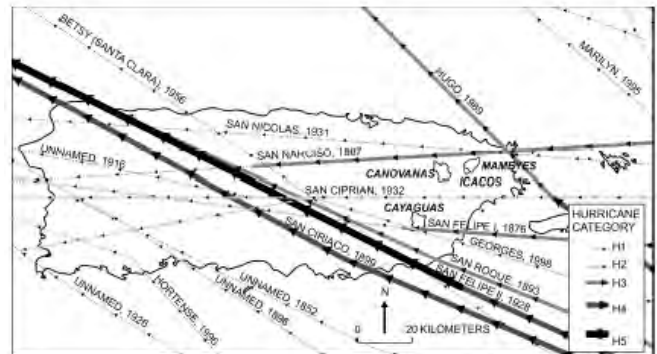

Figure 4. Hurricanes that have passed over or near Puerto Rico since 1850 (study watersheds outlined; data from National Oceanic and Atmospheric Administration 2006).

Atmospheric Inputs

The precipitation chemistry from the National Atmospheric Deposition Program (NADP) site at El Verde (National Atmospheric Deposition Program 2007), within the LEF in eastern Puerto Rico, is dominated by three major sources of solutes (Figure 5):

- Marine salts, which contribute about 82 percent of the ionic charge, including chloride, sodium, and magnesium;
- Temperate pollution from the Northern Hemisphere (10 percent), primarily nitrate, ammonia, and sulfate derived from pollution and natural sources—nitrogen loads have doubled since measurements began in 1985 (Stallard 2001); and
- Saharan Desert dust (5 percent), primarily from calcium carbonate.

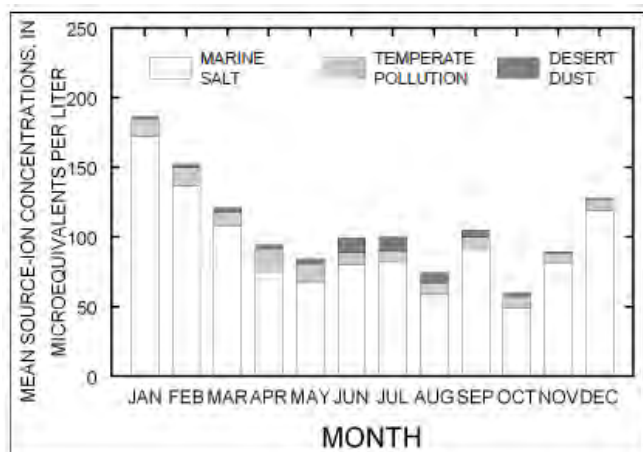

Figure 5. Mean monthly contributions of marine, temperate, and desert sources to rain chemistry in eastern Puerto Rico (data from NADP site at El Verde, 1985–2006; National Atmospheric Deposition Program 2007).

Massive sandstorms blowing off the Saharan Desert can blanket hundreds of thousands of square kilometers of the Atlantic Ocean. Although this dust fall has been going on for millions of years, the clearing of land south of the Sahara may be an additional contribution (Shinn et al. 2000). The transport of dust, pollution, and pathogens are affecting the health of coral, amphibians, and people (Shinn et al. 2000, Stallard 2001, Kuehn 2006). Moreover, the dust may play a role in decreasing the frequency and intensity of hurricanes formed over the Atlantic Ocean (Dunion and Velden 2004).

Stream chemistry was sampled during several large storms. Results indicate that some storms, mostly hurricanes, can contribute extremely large marine salt inputs. Hurricanes Hortense (1996) and Georges (1998) had comparable total rainfall, but Georges was shorter and more intense (Figure 6). Hortense produced 333 mm total runoff from the Mameyes watershed with an average stream-water chloride concentration of 111 micromoles/liter (μM), while Georges produced 317 mm total runoff with an average chloride concentration of 455 μM (R.F. Stallard, 2008, USGS, written commun.). Georges deposited the equivalent of 0.3 mm of seawater over the entire Mameyes watershed. This hurricane, and several other large storms, were missed in the NADP sampling, which occurs weekly. These results suggest that NADP may underestimate chloride inputs at El Verde, confounding mass-discharge programs such as LOADEST (Runkel et al. 2004).

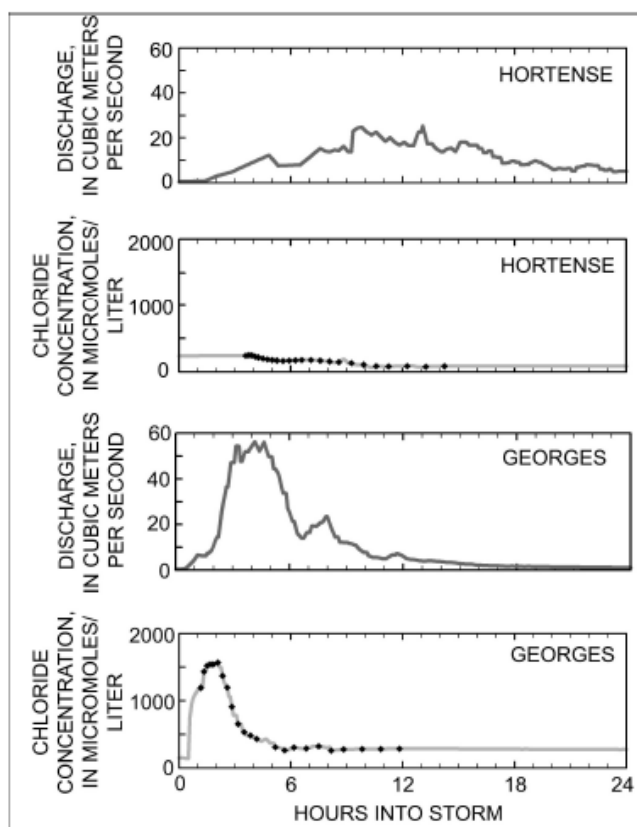

Figure 6. Discharge and chloride concentrations for the Río Mameyes during two hurricanes (R.F. Stallard, 2008, USGS, written commun.).

Summary

Eastern Puerto Rico is a changing environment. From within, it has a growing and urbanizing population. Forests are regrowing and increasing landscape-scale evapotranspiration at the same time that human populations are demanding more water. In addition, over the last several centuries, the climate appears to be getting drier (Zack and Larsen 1993). Water shortages are a major problem. In fact, during our study, droughts led to severe water rationing for the city of San Juan, with outages of more than 36 hours. This led to the hoarding of water in open containers and subsequent outbreaks of Dengue fever (Rigau-Pérez et al. 2001).

From afar, increasing temperate pollution, Saharan dust, and smog from the burning of African forests is changing the chemical landscape in Puerto Rico (Stallard 2001). Droughts, through dryness or warming, and along with the chemical changes, may contribute to the ongoing amphibian die-off (Stallard 2001, Burrowes et al. 2004).

Throughout Puerto Rico, floods caused by hurricanes and frontal storms damage infrastructure, and the associated suspended sediment clogs reservoirs and enters the ocean where it damages coral (Warne et al. 2005). The impact of large storms is affected by landcover and their intensity and frequency of occurrence. Presumably, ongoing forest recovery in Puerto Rico will lessen physical erosion. At the same time, however, the intensity or destructiveness of large storms may be increasing as a result of human-induced warming of the surface ocean (Emanuel 2005).

The 15-yr dataset described here provides the opportunity to evaluate and quantify the effects of these environmental conditions on the short-term quantity and quality of surface waters and provides a baseline for characterizing future environmental change. Implications from this study are transferable to other tropical regions where deforestation, rapid land-use change, and climate change are issues facing watershed managers and others concerned about the supply and quality of surface waters.

Acknowledgments

The work in Puerto Rico could not have been done without the participation and assistance of numerous people in Puerto Rico, Colorado, and elsewhere. In particular, we acknowledge contributions by Ellen Axtmann, Paul Collar, Matthew Larsen, Deborah Martin, and Angel Torres-Sánchez. The authors greatly appreciate the helpful reviews of Kimberly Wickland and Richard Webb.

References

Bawiec, W.J. 2001. Geology, geochemistry, geophysics, mineral occurrences, and mineral resource assessment for the commonwealth of Puerto Rico. U.S. Geological Survey, Open-File Report 98-38, CD-ROM.

Brown, E.T., R.F. Stallard, M.C. Larsen, G.M. Raisbeck, and F. Yiou. 1995. Denudation rates based on accumulation of in situ-produced ^{10}Be compared with watershed mass balance results in the Luquillo Experimental Forest, Puerto Rico. *Earth and Planetary Science Letters* 129:193–202.

Burrowes, P.A., R.L. Joglar, and D.E. Green. 2004. Potential causes for amphibian declines in Puerto Rico. *Herpetologica* 60:141–154.

Dunion, J., and C.S. Velden. 2004. The impact of the Saharan air layer on Atlantic tropical cyclone activity. *Bulletin of the American Meteorological Society* 85:353–365.

Emanuel, K. 2005. Increasing destructiveness of tropical cyclones over the past 30 years. *Nature* 436:686–688.

Jackson, R.B., E.G. Jobbágy, R. Avissar, S.B. Roy, D.J. Barrett, C.W. Cook, K.A. Farley, D.C. le Maitre, B.A. McCarl, and B.C. Murray. 2005. Trading water for carbon with biological carbon sequestration. *Science* 310:1,944–1,947.

Kuehn, B.M. 2006. Desertification called global health threat. *Journal of the American Medical Association* 295:2,463–2,465.

Larsen, M.C., and A. Santiago-Román. 2001. Mass wasting and sediment storage in a small montane watershed: An extreme case of anthropogenic disturbance in the humid tropics. In J.M. Dorava, B.B. Palcsak, F. Fitzpatrick, and D. Montgomery, eds., *Geomorphic Processes and Riverine Habitat*, pp. 119–138. American Geophysical Union, Water Science and Application Series 4.

Larsen, M.C., and R.M.T. Webb. 2009. Potential effects of runoff, fluvial sediment, and nutrient discharges on the coral reefs of Puerto Rico. *Journal of Coastal Research*: 25:189–208.

National Atmospheric Deposition Program. 2007. National trends network. Illinois State Water Survey. [online] URL: <http://nadp.sws.uiuc.edu/NTN>. Accessed 13 September 2007.

National Oceanic and Atmospheric Administration. 2006. Historical North Atlantic and East-Central North Pacific Tropical Cyclone Tracks, 1851–2006. [online] URL: <http://maps.csc.noaa.gov/hurricanes>. Accessed 25 May 2008.

Rigau-Pérez, J.G., A.V. Vorndam, and G.G. Clark. 2001. The dengue and dengue hemorrhagic fever

epidemic in Puerto Rico, 1994–1995. *The American Journal of Tropical Medicine and Hygiene* 64:67–74.

Runkel, R.L., C.G. Crawford, and T.A. Cohn. 2004. Load Estimator (LOADEST): A FORTRAN program for estimating constituent loads in streams and rivers. U.S. Geological Survey, Techniques and Methods Book 4, Chapter A5.

Shinn, E.A., G.W. Smith, J.M. Prospero, P. Betzer, M.L. Hayes, V. Garrison, and R.T. Barber. 2000. African dust and the demise of Caribbean coral reefs. *Geophysical Research Letters* 27:3,029–3,032.

Simon, A., M.C. Larsen, and C.R. Hupp. 1990. The role of soil processes in determining mechanisms of slope failure and hillslope development in a humid-tropical forest, eastern Puerto Rico. In P.L.K. Kneuper and L.D. McFadden, eds., *Soils and Landscape Evolution*, pp. 263–286. *Geomorphology* special issue, v. 3.

Stallard, R.F. 2001. Possible environmental factors underlying amphibian decline in eastern Puerto Rico: Analysis of US government data archives. *Conservation Biology* 15:943–953.

Warne, A.G., R.M.T. Webb, and M.C. Larsen. 2005. Water, sediment, and nutrient discharge characteristics of rivers in Puerto Rico, and their potential influence on coral reefs. U.S. Geological Survey, Scientific Investigations Report 2005-5206.

Zack, A., and M.C. Larsen. 1993. Island hydrology: Puerto Rico and the U.S. Virgin Islands. *Research & Exploration (National Geographic)*, Water Issue:126–134.

Human Impacts and Management—Abstracts

The Importance of Considering Aquifer Susceptibility and Uncertainty in Developing Water Management and Policy Guidelines

Tristan Wellman

Abstract

The responsibility for providing safe drinking water to residents of the United States is shared by many organizations at the Federal, State, and local levels. A substantial component of this effort is focused on the quality of groundwater, which yields approximately one-third of all drinking water to communities through public supply wells. Observed groundwater quality is influenced by several factors of both natural and human origin. Many of the natural factors that affect aquifer susceptibility pertain to an aquifer's physical characteristics, such as the depth to water, permeability of the geologic media, and amount of water in storage. Other factors of natural origin may be related to the hydrologic conditions, such as the net recharge to an aquifer from precipitation and snow melt, and the linkage between surface-water bodies and the underlying aquifer. These natural components control the time required for chemical constituents to reach the water table, the residence time that they remain in the aquifer, and the resulting concentrations. Additional influences may be related to human activities, such as land-use zoning, population density, and urban infrastructure. Water managers must carefully consider all of the factors that influence aquifer susceptibility, as well as the implications of changing water quality on human health. An effective means of estimating both the current and future changes to aquifer susceptibility is through the use of hydrologic models. Predictions of aquifer susceptibility may vary temporally and spatially for different regions in an aquifer to the extent that a single generalization of susceptibility is unwarranted. It is equally important to consider that estimates of susceptibility are uncertain. Thus, to properly manage water quality in the face of changing natural and human-related conditions, managers must adapt management practices to estimated levels of susceptibility while considering the uncertainty in these predictions. Case studies of principal aquifers throughout the United States are compared and contrasted as a means to provide a broad overview of these points.

Wellman is a hydrologist with the U.S. Geological Survey, Denver, CO. Email: twellman@usgs.gov.

Water Quality Screening Tools: A Practical Approach

Benjamin Houston, Rob Klosowski

Abstract

Water quality modeling has typically been beyond the domain of most local government agencies, and their use in practical decision making at the local level has often not been realized. In locations where more robust calibrated models are not readily available for use in local land use management programs, simple screening level tools offer great promise in assisting local efforts at prioritizing pollutant sources and improving water quality.

This investigation reports on several approaches to bring a range of water quality assessment tools into the domain of programs and decisionmaking at the local level. An emphasis on simple risk-based approaches to several tested protocols has resulted in practical value for local watershed management and non-point source control activities in upstate New York. The role of riparian buffer zones, land-use-based contributions to sediment and nutrient loading, and saturation excess contributions to runoff are evaluated in the context of prioritizing the relative effects on stream water quality.

Attempts to use the Riparian Buffer Delineation Equation (RBDE) have been frustrated by an emphasis on calculating specific variable-width buffer distances along individual stream segments. The RBDE is designed to evaluate the effectiveness of a particular riparian zone at reducing pollutant and sediment loading in comparison with a reference condition across an entire watershed. The methods developed here present results from implementing the RBDE in the form of both a sensitivity index and a current risk ratio. All variables are determined objectively from existing GIS datasets. This strategy has important implications for objectively evaluating the value of existing riparian buffers in particular stream reaches and for guiding management strategies toward improving riparian buffer conditions as one technique to improve environmental water quality.

Export coefficient models have been widely accepted as screening level tools for assessing contributions to sediment and nutrient loading within specific watershed units. The method presented here offers local government officials and staff a simple to use approach for assessing current and proposed land use scenarios in the context of management strategies for reducing non-point source contributions. Inputs are based entirely on existing landcover and terrain raster GIS datasets. The results have been used to assist program managers in prioritizing areas of greatest risk and evaluating scenarios for improvement.

Saturation excess has also been established as a primary mechanism for the mobilization of nutrients and sediment in runoff in the northeast region of the United States. A simple GIS-based tool grounded in variable source area (VSA) hydrology offers an alternative view into areas of greatest risk from traditional infiltration excess models based on the National Resources Conservation Service (NRCS) Curve Number method. Inputs are based entirely on soil and terrain raster GIS datasets that are ubiquitously available and offer the potential to help guide local land use managers in determining where source areas exist in the context of ongoing efforts to reduce pollutant loads.

When used together to augment ongoing program efforts, these screening level tools offer immediate and cost effective ways for programs to evaluate strategies and prioritize efforts within their watersheds.

Houston and Klosowski are environmental information management professionals with the Institute for the Application of Geospatial Technology, Auburn, NY. Email: bhouston@iagt.org; rklosowski@iagt.org.

Herbicide Transport Trends in Goodwater Creek Experimental Watershed

R.N. Lerch, E.J. Sadler, K.A. Sudduth, C. Baffaut

Abstract

Hydrologic transport of soil-applied herbicides continues to be of great concern relative to contamination of surface waters in the United States. The objectives of this study were to analyze trends in herbicide concentrations and loads in Goodwater Creek Experimental Watershed (GCEW) from 1992 to 2006, and to conduct a retrospective assessment of the potential aquatic ecosystem impacts caused by atrazine contamination using screening criteria established by the U.S. Environmental Protection Agency (USEPA). Located within the Central Claypan Region of northeastern Missouri, GCEW encompasses 77 km² of predominantly agricultural land uses, with an average of 21 percent of the watershed in corn or sorghum. Flow-weighted runoff and weekly base flow grab samples were collected from 1992 to 2006 near the outlet to GCEW and analyzed for acetochlor, alachlor, atrazine, and metolachlor. Using cumulative frequency diagrams and correlation analyses, the results showed no significant time trends for atrazine concentration, but the other herbicides showed trends based on changes in use. Atrazine had the highest relative loads, with a median of 5.9 percent of applied lost annually. Variation in annual loads was a function of the timing of runoff events relative to herbicide application within the watershed, and the magnitude of runoff events was a much less important factor to transport. Atrazine reached concentrations that may be harmful to aquatic ecosystems in 10 out of 15 years, and concentrations typically exceeded the screening criteria for days to weeks each year. Because the atrazine ecological criteria established under the USEPA interim re-registration eligibility decision were exceeded, atrazine registrants will be required to work with farmers in the watershed to implement practices that reduce atrazine transport.

Lerch and Sadler are soil scientists, Sudduth is an agricultural engineer, and Baffaut is a hydrologist, all with the U.S. Department of Agriculture, Agricultural Research Service, Cropping Systems and Water Quality Research Unit, Columbia, MO. Email: Bob.Lerch@ars.usda.gov; John.Sadler@ars.usda.gov; Ken.Sudduth@ars.usda.gov; Claire.Baffaut@ars.usda.gov.

A Watershed Condition Assessment of Rocky Mountain National Park Using the FLoWS Tools

David M. Theobald, John B. Norman

Abstract

Increasingly, the management of natural resources requires “thinking big” at broad ecoregional scales and “thinking process” to more directly incorporate important ecological processes that flow across boundaries. This type of ecosystem management has been recently required by watershed-level assessments for Federal agencies and ecoregional planning by nongovernmental organizations. In this presentation we will describe the watershed-based framework we have developed to conduct an assessment of ecological condition in Rocky Mountain National Park (RMNP). We will describe some general findings of our analysis in RMNP and more generally place these findings within a broader watershed analytical framework. In particular, we will describe the use of the FLoWS tools (Functional Linkage of Water basins and Streams) built for ArcGIS and the detailed, consistent, and refined spatial dataset that provides basic and advanced watershed attributes, including estimates of likely effects of near-term (approximately 20–30 years) climate change. To build this FLoWS dataset we have integrated 1:24k (and 30-m National Elevation Dataset) into the 1:100k National Hydrography Dataset structure to produce both networked watersheds with attributes as well as key raster datasets such as overland and instream flow distances. Our approach represents a conceptual shift from lumped analyses of watersheds to a network-based framework that allows integration of likely threats through spatial analyses that directly incorporate hydrological processes.

Theobald is an associate professor and Norman is a research associate at the Department of Human Dimensions of Natural Resources and Natural Resource Ecology Lab, Warner College of Natural Resources, Colorado State University, Fort Collins, CO. Email: davet@warnercnr.colostate.edu; norm@nrel.colostate.edu.

Human Impacts and Management—Manuscripts

Long-term Patterns of Hydrologic Response after Logging in a Coastal Redwood Forest

Elizabeth Keppeler, Leslie Reid, Tom Lisle

Abstract

Experimental watersheds generally provide the only setting in which the more subtle patterns of long-term response to land use activities can be defined. Hydrologic and sediment responses have been monitored for 35 yrs after selective logging and for 16 yrs after clearcut logging of a coastal redwood forest at the Caspar Creek Experimental Watersheds in northwest California. Results show that recovery periods differ for different hydrologic attributes and between the two silvicultural treatments. Total water yield, peakflows, and low flows responded similarly in both settings during the initial post-logging period, but low flows reattained pre-treatment levels more quickly after selective logging. Sediment loads initially recovered relatively quickly after both treatments, but in both cases loads rose once again 10–20 yrs after logging, either because road networks began to fail (South Fork) or because pre-commercial thinning again modified hydrologic conditions (North Fork).

Process-based studies provide the information needed to understand the differing watershed responses. Altered interception after logging provides the primary influence on water yield and peakflow responses, while altered transpiration is largely responsible for the low-flow response. Differences in recovery times between hydrologic attributes and between silvicultural practices may be explained by changes in the relative importance of interception and transpiration and by the long-lasting repercussions of ground disturbance.

Keywords: streamflow, sediment, hydrologic recovery, timber harvest, cumulative watershed effects

Keppeler is a hydrologist, Reid is a geomorphologist, and Lisle is a hydrologist and project leader, all with U.S. Department of Agriculture, Forest Service, Pacific Southwest Research Station, 1700 Bayview Drive, Arcata, CA 95521. Email: ekeppeler@fs.fed.us; lreid@fs.fed.us; tlisle@fs.fed.us.

Introduction

Since the installation of stream gaging weirs on the North and South Forks of Caspar Creek in 1962, researchers have been investigating the effects of forest management on streamflow, sedimentation, and erosion under a partnership between State and Federal forestry agencies. As the hydrologic record lengthens following experimental treatments, differing patterns of recovery have become evident. A suite of ongoing process-based studies provides the information needed to understand the contrast in watershed responses. Previous publications detail the range of hydrologic response to the logging treatments. Here, we discuss results from further analyses and provide an updated look at recovery in the Caspar Creek Experimental Watersheds.

Methods

Site

The Caspar Creek Experimental Watersheds are located on the Jackson Demonstration State Forest about 7 km from the Pacific Ocean and about 10 km south of Fort Bragg in northwestern California at 39°21'N 123°44'W (Figure 1). The watersheds are incised into uplifted marine terraces underlain by greywacke sandstone and weathered, coarse-grained shale of late Cretaceous to early Cenozoic age.

Elevations in the watersheds range from 37 to 320 m. Hillslopes are steepest near stream channels and become gentler near the broad, rounded ridgetops. About 35 percent of the slopes are less than 17 degrees and 7 percent are steeper than 35 degrees. Soils are 1- to 2-m-deep, well-drained clay-loams. Hydraulic conductivities are high and subsurface stormflow is rapid, producing saturated areas of only limited extent and duration.

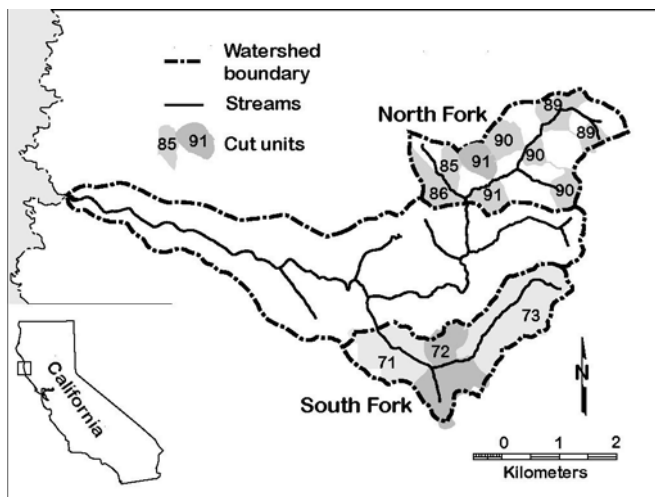

Figure 1. Caspar Creek Experimental Watersheds and 20th century harvest dates.

The climate is typical of low-elevation coastal watersheds of the Pacific Northwest. Winters are mild and wet, characterized by frequent, low-intensity rainstorms interspersed with occasional high-intensity events. About 95 percent of the average annual precipitation of 1,170 mm falls October through April, and snow is rare. Summers are moderately warm and dry, with maximum temperatures moderated by frequent coastal fog. Mean annual runoff is 650 mm.

Like most of California's north coast, the watersheds were clearcut and broadcast burned largely prior to 1900. By 1960, the watersheds supported an 80-year-old second-growth forest with a stand volume of about 700 m³ ha⁻¹, composed of coast redwood (*Sequoia sempervirens*), Douglas-fir (*Pseudotsuga menziesii*), western hemlock (*Tsuga heterophylla*), and grand fir (*Abies grandis*).

Study design

The Caspar Creek study is a classic paired watershed design where one or more gaged catchments are designated as controls and others are treated with road building, logging, and other timber management practices. Statistical relationships are first defined between control watersheds and those to be treated, then post-treatment responses are evaluated as the deviation between observed conditions and those expected based on the pre-treatment calibrations.

The 473-ha North Fork and the 424-ha South Fork of Caspar Creek have been gaged continuously since 1962 using 120° V-notch weirs widening to concrete

rectangular sections for high discharges. During the early 1980s, three rated sections were constructed upstream of the North Fork weir and 10 Parshall flumes were installed on tributary reaches with drainage areas of 10 to 77 ha.

Stream discharge was initially recorded using mechanical chart recorders. These were replaced in the mid-1980s with electronic data loggers equipped with pressure transducers. Subsequent upgrades have been implemented as technology has progressed. Early suspended sediment estimates were derived from sediment rating curves, manual depth-integrated sampling, and fixed stage samplers (Rice et al. 1979). Statistically based sampling algorithms that trigger automated samplers were utilized beginning in the 1980s (Lewis et al. 2001). Sediment accumulations in the weir ponds have been surveyed annually since 1963.

South Fork treatment: Selection harvest with tractor yarding

Calibration relationships between the North and South Forks were established for flow and sediment by 1967.

That year, right-of-way logging and road construction along the riparian corridor proceeded in the South Fork. The watershed response to roading was monitored for 4 yrs before the remainder of South Fork watershed was logged and tractor yarded between 1971 and 1973. Single-tree and small group selection was used to harvest about two-thirds of the stand volume. Roads, landings, and skid trails covered approximately 15 percent of the watershed area (Ziemer 1981).

North Fork treatment: Clearcutting with skyline-cable yarding

A study of cumulative effects began in 1985 in the North Fork watershed. Three gaged tributary watersheds within the North Fork were selected as controls, while five were designated for harvest in compliance with the California Forest Practice rules. Two additional downstream units (13 percent of the North Fork watershed) were clearcut in 1985–86 and excluded from the cumulative effects study. After the 1985–89 calibration period, clearcut logging began elsewhere in the study area in May 1989 and was completed in January 1992. Clearcuts totaling 162 ha occupied 30–99 percent of treated watersheds. Between 1985 and 1992, 46 percent of the North Fork watershed was clearcut, 1.5 percent was thinned, and 2 percent was cleared for road rights-of-way (Henry 1998).

In contrast to the harvest treatment of the South Fork in the 1970s, watercourse protection rules mandated equipment exclusion and 50 percent canopy retention within 15–46 m of streams containing aquatic organisms. Skyline-cable systems yarded 81 percent of the clearcut area from log landings constructed far from streams. New road construction and tractor skidding was restricted to ridgetop locations with slopes of generally less than 20 percent. Four harvest blocks, 92 ha total, were broadcast burned and later treated with herbicide to control competition (Lewis et al. 2001). Pre-commercial thinning in 1995, 1998, and 2001 eliminated much of the dense regrowth, reducing basal area in treated units by about 75 percent.

Results

Water yield and low flows

Both treatments resulted in increased water yields for a period of 10 yrs or more (Keppeler and Ziemer 1990, Keppeler 1998). When calculated per unit of equivalent clearcut area, the magnitudes of the initial changes were found to be quite similar (Figure 2), but South Fork began to show a trend toward recovery after 7 yrs while North Fork did not. Changes in low flow exhibited a contrasting pattern. Initial changes were similar in the North and South Forks, but South Fork low flows recovered to pre-treatment conditions within 8 yrs of logging, while North Fork low flows had not recovered by year 14.

The contrast in low flow responses between the two experiments probably reflects the difference in silvicultural treatments used. In the South Fork, about a third of the tree canopy remained distributed across the landscape after logging, and the surviving trees no longer had competition for dry-season soil moisture. Under these conditions, actual dry-season transpiration could more closely approach potential transpiration, and the post-logging “excess” of water would contribute to transpiration once root networks expanded. In North Fork clearcuts, no nearby trees could take advantage of the excess water, and this water instead will continue to contribute to dry-season flows until new vegetation is well established on the cut units. In addition, most North Fork clearcut units were later treated with herbicides and pre-commercially thinned, again reducing leaf area and suppressing transpiration.

Water yields, in contrast, are dominated by wet-season flows. After logging at Caspar Creek, the change in foliar interception of rainfall was found to be a stronger influence on the wet-season water balance than was transpiration (Reid and Lewis 2007), as about 22 percent of rainfall is intercepted by foliage in uncut stands (Reid and Lewis 2007). In the case of interception, rates depend more strongly on the amount of canopy removed than on the distribution of remaining trees. The wet-season response—reflected by the water yield—is thus more similar for the two silvicultural strategies than is the transpiration-dependent dry-season response.

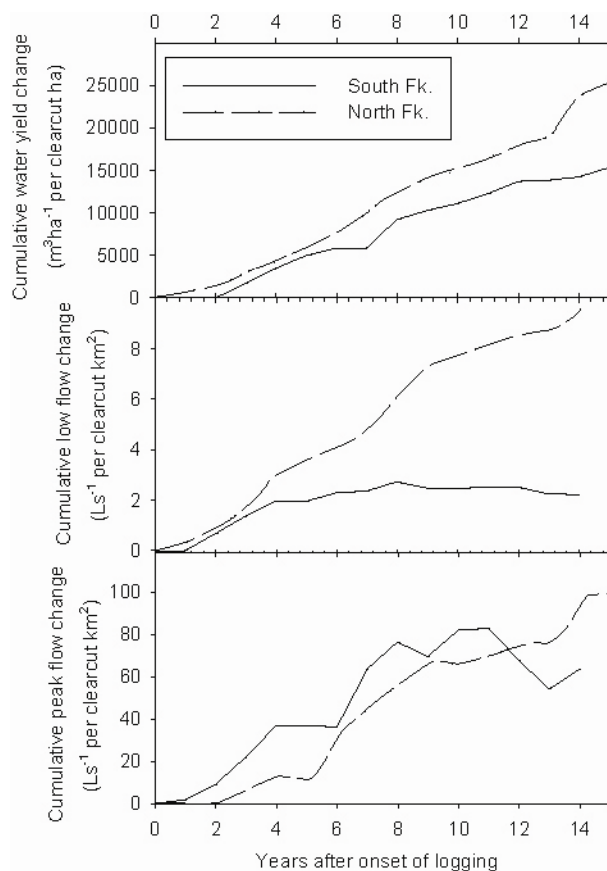

Figure 2. Cumulative change per unit area of clearcut equivalent by time after major logging for water yield, low flow, and peak flow. Minor logging occurred 4 yrs before the major onset in both watersheds and thinning occurred in the North Fork in years 6, 9, and 12.

Peakflows

Changes in major winter peakflows were not initially detected in the dataset from the South Fork, but reanalysis using temporal categories suggested by

North Fork results showed a statistically significant increase between 3 months and 8 years after logging ended. The discharge-weighted average peakflow was 13 percent higher than predicted and the 2-yr storm peak increased 14 percent.

The North Fork study design, wherein five clearcut tributaries and three control tributaries were gaged, yielded a larger dataset. Storm peaks with 2-yr return periods increased an average of 27 percent in the fully clearcut watersheds (Ziemer 1998), and in partially clearcut watersheds the magnitude of the change was proportional to the percentage of the watershed logged (Lewis et al. 2001). Peakflows in clearcut watersheds had nearly reattained pre-treatment levels within about 10 yrs after logging, but pre-commercial thinning then triggered new increases. As of 2007, ongoing measurements in two fully clearcut watersheds indicate that peakflows remain an average of 40 percent above pre-treatment predictions 6 yrs after pre-commercial thinning and 16 yrs after logging (Figure 3).

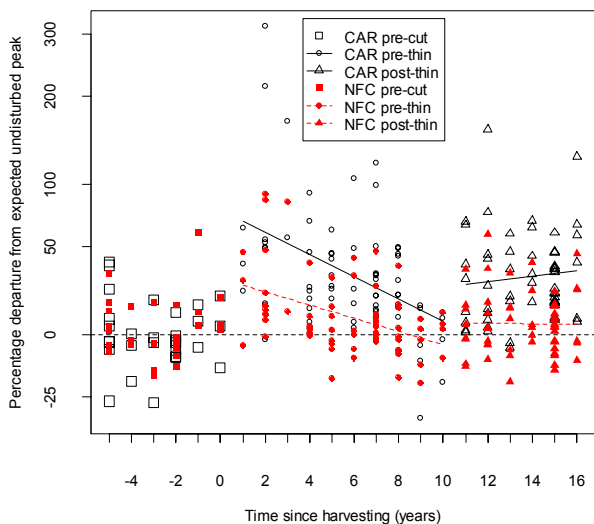

Figure 3. Peakflow departures from predicted in a 26-ha clearcut catchment (CAR) tributary to the 37 percent partially clearcut North Fork (NFC).

Sediment loads

The initial sediment responses following the logging on the South Fork (1971–73) was far greater than that on the North Fork (1989–92). South Fork suspended load more than quadrupled during the 6-yr period after tractor logging, while that in the North Fork roughly doubled during the equivalent post-harvest period (Lewis 1998). In both cases, sediment yields neared or reattained pre-treatment levels by about a decade after

logging. In the South Fork, much of the excess sediment production is directly attributed to road-related erosion and mass-wasting (Rice et al. 1979)—problems that were more effectively avoided on the North Fork, where road and skid trail construction was much more limited.

Recent work suggests that an important component of the excess sediment in the North Fork may originate from sources within channels, thus making sediment loads particularly sensitive to logging-related increases in flow. Data from a pair of nested stream gages illustrate the potential importance of in-stream sediment sources. The 27-ha EAG clearcut watershed lies at the headwaters of the 77-ha DOL catchment, which otherwise has not been logged since 1904. Suspended sediment loads measured during storms at the EAG gauge were subtracted from corresponding loads at the DOL flume to estimate the load derived from the unlogged portion of the DOL watershed. These loads were then compared to those expected on the basis of pre-treatment calibrations to control watersheds. The ratio of observed to expected load in the unlogged portion of DOL shows a response similar in initial timing and magnitude to that within the logged watershed upstream (Figure 4). Field observations indicate that bank and headcut erosion in the mainstem DOL channel are the principal sources of sediment in the non-logged portion of the watershed.

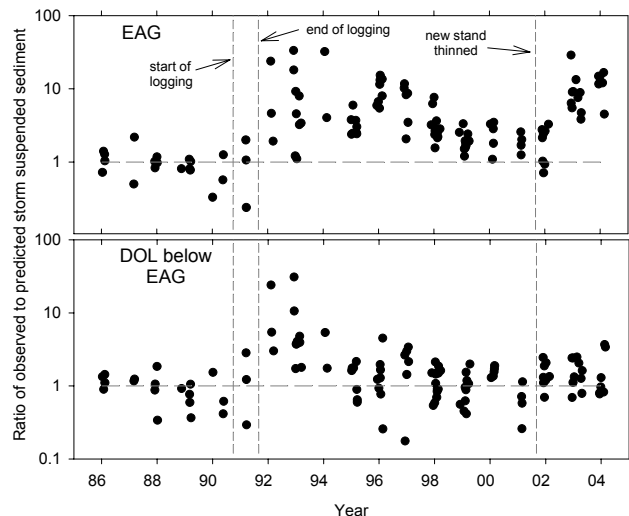

Figure 4. Suspended sediment loads observed in North Fork clearcut EAG and at downstream station DOL from hydrologic year 1986 through 2004.

Although sediment loads in both the South and North Fork watersheds had essentially recovered to

pre-treatment levels within a decade of logging (Thomas 1990, Lewis 1998), both subsequently showed renewed increases. On the South Fork, deterioration of the road system contributed to a new period of excess sediment input beginning about 20 yrs after second-cycle logging (Keppeler and Lewis 2007). On the North Fork, pre-commercial thinning 10 yrs after logging again increased runoff and peakflows (Figure 4), triggering renewed channel erosion just as excess loads had nearly recovered. Added to this excess load is the sediment input from a major landslide on a logged slope of the North Fork in 2006.

Discussion

The relative importance of different components of the water balance varies seasonally at Caspar Creek (Figure 5), and those components respond to different silvicultural practices and to post-logging regrowth in different ways. As a result, each seasonally dependent attribute of streamflow demonstrates a unique response and recovery trajectory that is a composite response to a set of changes affecting interception, transpiration, and flow path. Transpiration dominates the water balance during the long dry season, so recovery of dry-season flows would track the recovery of transpiration potential following logging. Peakflows, in contrast, occur during months when the influence of decreased interception after logging is about twice that of transpiration reductions. Water yield, which principally reflects wet-season flows, would also be most strongly influenced by changes in rainfall interception after logging.

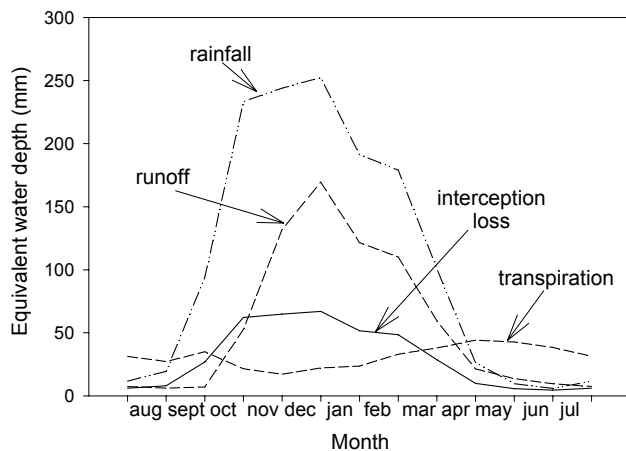

Figure 5. Monthly water balance for forested watersheds, North Fork Caspar Creek (from Reid and Lewis 2007).

Logging-related sediment inputs do not follow a smooth path to recovery. Although much of the initial increase in sediment loads in the North Fork was correlated with increased runoff (Lewis et al. 2001), hydrologic recovery has not translated into a sustained return to pre-treatment sediment loads in the South Fork. In fact, sediment loads 34 yrs after logging are once again nearly equivalent to those in the period immediately following logging. Dry years are now relatively quiescent in terms of sediment production, but years with multiple large storm events generate significant excess sediment.

In the North Fork, increased sediment loads following pre-commercial thinning are large relative to the magnitude of renewed increases in peak flow, suggesting that the new hydrologic conditions are interacting with other changes still present from second-cycle logging. This might be the case, for example, if the new reductions in transpiration and interception are synchronous with the post-logging minimum in root cohesion on hillslopes, or if channel banks already destabilized by the earlier period of increased flow are now subjected to new increases. Additional sediment might also be contributed by remobilization of logging-related sediment that remains in storage in channels downstream of logged areas or that had been trapped behind now decayed logging slash in low-order channels. In each case, new hydrologic changes interact with conditions generated earlier by logging, and the cumulative effect of the interaction is a disproportionate increase in sediment relative to that predicted on the basis of flow effects alone.

Evidence of altered hydrology, in the form of compaction, gullied stream channels, and diversions along abandoned roads and skid trails, persists in Caspar Creek's logged watersheds even as the forest regrows, maintaining an increased susceptibility of the landscape to the effects of major storms. In the North Fork, pre-commercial thinning renewed hydrologic changes, again reducing hillslope stability and contributing to channel adjustments. Through such mechanisms, the potential for enhanced sediment production may be sustained for prolonged periods after logging.

Conclusions

Timber harvest alters forest hydrology by forest canopy reduction and ground disturbances associated with road

construction, yarding, and site preparation. Recovery is governed by the rate of revegetation and the more gradual amelioration of ground disturbances and channel re-stabilization. Watershed-scale studies are useful for documenting the hydrologic response over a range of conditions while exploring the cause-and-effect linkages that explain variations in ecosystem response. Long-term studies, such as those at Caspar Creek, are particularly important for disclosing the deviations from recovery trajectories following natural or management-related shifts in vegetation conditions occurring as regrowth proceeds, or as global climatic patterns shift.

Acknowledgments

Authors are grateful to the California Department of Forestry and Fire Protection (CAL FIRE) for their cooperation and support of the Caspar Creek research.

References

Henry, N.D. 1998. Overview of the Caspar Creek Watershed study. In R.R. Ziemer, technical coordinator, Proceedings of the Conference on Coastal Watersheds: The Caspar Creek Story, Ukiah, CA, 6 May 1998, pp. 1–9. U.S. Department of Agriculture, Forest Service, Pacific Southwest Forest and Range Experiment Station, General Technical Report PSW GTR-168, Albany, CA.

Keppeler, E.T. 1998. The summer flow and water yield response to timber harvest. In R.R. Ziemer, technical coordinator, Proceedings of the Conference on Coastal Watersheds: The Caspar Creek Story, Ukiah, CA, 6 May 1998, pp. 35–43. U.S. Department of Agriculture, Forest Service, Pacific Southwest Forest and Range Experiment Station, General Technical Report PSW GTR-168, Albany, CA.

Keppeler, E., and J. Lewis. 2007. Understanding the hydrologic consequences of timber-harvest and roading: Four decades of streamflow and sediment results from the Caspar Creek experimental watersheds. In M. Furniss, C. Clifton, and K. Ronnenberg, eds., *Advancing the Fundamental Sciences: Proceedings of the Forest Service National Earth Sciences Conference*, San Diego, CA, 18–22 October 2004, pp. 191–196. U.S. Department of Agriculture, Forest Service, Pacific Northwest Research Station, General Technical Report PNW-GTR-689, Portland, OR.

Keppeler, E.T., and R.R. Ziemer. 1990. Logging effects on streamflow: Water yields and summer low flows at Caspar Creek in northwestern California. *Water Resources Research* 26(7):1,669–1,679.

Lewis, J. 1998. Evaluating the impacts of logging activities on erosion and sediment transport in the Caspar Creek watersheds. In R.R. Ziemer, technical coordinator, Proceedings of the Conference on Coastal Watersheds: The Caspar Creek Story, Ukiah, CA, 6 May 1998, pp. 55–69. U.S. Department of Agriculture, Forest Service, Pacific Southwest Forest and Range Experiment Station, General Technical Report PSW GTR-168, Albany, CA.

Lewis, J., S.R. Mori, E.T. Keppeler, and R.R. Ziemer. 2001. Impacts of logging on storm peakflows, flow volumes and suspended sediment loads in Caspar Creek, California. In M.S. Wigmosta and S.J. Burges, eds., *Land Use and Watersheds: Human Influence on Hydrology and Geomorphology in Urban and Forest Areas*. *Water Science and Application*, v. 2, pp. 85–125. American Geophysical Union, Washington DC.

Reid, L.M., and J. Lewis. 2007. Rates and implications of rainfall interception in a coastal redwood forest. In R.B. Standiford, G.A. Giusti, Y. Valachovic, W.J. Zielinski, and M.J. Furniss, technical eds., Proceedings of the Redwood Region Forest Science Symposium: What Does the Future Hold?, Rhonert Park, CA, 15–17 March 2004, pp. 107–117. U.S. Department of Agriculture, Forest Service, Pacific Southwest Research Station, General Technical Report PSW-GTR-194, Albany, CA.

Rice, R.M., F.B. Tilley, and P.A. Datzman. 1979. A watershed's response to logging and roads: South Fork of Caspar Creek, California, 1967–1976. U.S. Department of Agriculture, Forest Service, Pacific Southwest Forest and Range Experiment Station, Research Paper PSW-146.

Thomas, R.B. 1990. Problems in determining the return of a watershed to pretreatment conditions: Techniques applied to a study at Caspar Creek, California. *Water Resources Research* 26(9):2,079–2,087.

Ziemer, R.R. 1981. Stormflow response to roadbuilding and partial cutting in small streams of northern California. *Water Resources Research* 17(4):907–917.

Ziemer, R.R. 1998. Flooding and stormflows. In R.R. Ziemer, technical coordinator, Proceedings of the Conference on Coastal Watersheds: The Caspar Creek Story, Ukiah, CA, 6 May 1998, pp. 15–24. U.S. Department of Agriculture, Forest Service, Pacific Southwest Forest and Range Experiment Station, General Technical Report PSW GTR-168, Albany, CA.

Recognizing Change in Hydrologic Functions and Pathways due to Historical Agricultural Use: Implications to Hydrologic Assessments and Modeling

Carl C. Trettin, Devendra M. Amatya, Charles Kaufman, Norman Levine, Robert T. Morgan

Abstract

Documenting the recovery of hydrologic functions following perturbations is important to addressing issues associated with land use change and ecosystem restoration. Floodplains on the Santee Experimental Forest were used historically for rice cultivation in the early 1700s; those areas now support bottomland hardwood forests typical of the region. Recently acquired LIDAR data for the Santee Experimental Forest were used to delineate remnant historical water management structures within the watersheds. Hydrologic functions and pathways were altered during the agricultural use period, with changes to depression storage, streamflow and runoff routing. Since the late 1800s the land was left to revert to forests without direct intervention. The resultant bottomlands, while typical in term of vegetative structure and composition, still have altered hydrologic functions as a result of the historical land use. The application of high resolution LIDAR surface elevation data is expected to improve the basis for modeling and hydrological assessments.

Keywords: LIDAR data, historical land use, rice field, forest hydrology, drainage

Trettin is a team leader, and Amatya is a research hydrologist, both with the Center for Forested Wetlands Research, U.S. Forest Service, Cordesville, SC. Kaufman is a research associate, and Levine is an assistant professor, both with the Department of Geology and Environmental Geosciences, College of Charleston. Morgan is the Heritage Program Manager, Francis Marion Sumter National Forest, Huger, SC.

Introduction

Watersheds are an organizing framework for the assessment of hydrologic and ecological functions of the landscape. Resource data characterizing the watersheds is the basis for those assessments, and their resolution may affect results and interpretations. In this paper we illustrate how the recognition of historical land use features on the landscape, as a result of high resolution spatial data, affects our understanding of hydrologic processes and pathways. We use hydrologic modeling as an illustration because resolution of the resource data (e.g., soils, land use, topography, hydrography, vegetation) used as model inputs and the model design may affect interpretations. Most process-based models require some form of calibration or validation prior to applications; that calibration process typically involves modifying parameters or coefficients to achieve reasonable performance with respect to the calibration data. The assumption is that the reasonable agreement between the simulated and measured data (e.g., stream discharge) reflects an accurate representation of the processes within the watershed. However, seemingly accurate predictions of streamflow may be achieved by complementary errors from internal processes, resulting in inaccurate predictions of in-stream flows, water table depths, etc. within the watershed (Ambroise et al. 1995, Hatterman et al. 2004).

Floodplains in the coastal plain of the southeastern United States were the principal agricultural zone during the early colonial era (e.g., late 1600s and early 1700s). In South Carolina, the freshwater flood plains were used for rice cultivation. The development of the land included reservoirs,

impoundments, diversion and distribution channels, diked fields, and collection ditches (Hilliard 1978). Those manmade features remain on the landscape, but they are not apparent in the resource data that are commonly used for hydrologic assessments and modeling. The common U.S. Geological Survey (USGS) topographic survey information (e.g., 1:24,000) is of insufficient resolution to demark these features; hence, what are the potential ramifications to hydrologic assessments? To address this question we analyze LIDAR (light detection and ranging) data and summarize field observations on the Santee Experimental Forest, SC.

Approach

Site

This work was conducted on the U.S. Forest Service Santee Experimental Forest (SEF) in South Carolina. The SEF is representative of the lower coastal plain landscape, characterized by low relief, mixed hardwood-pine flatwoods and bottomland hardwood floodplains. The surface microtopography is characterized by shallow pit and mound relief, but there are also remnant structures from past agricultural use. The SEF was part of the Cypress Barony that was conveyed by the Lords Proprietors in 1681; the land was subsequently divided into three plantations in 1707, which is when the agricultural development began. The floodplains of first-, second-, and third-order streams were developed into rice fields during the early 1700s. The present topographic, hydrographic, soils, and vegetative information for the forest conveys a uniform, low-relief landscape (Figure 1). These are the typical spatial data that are used for hydrologic modeling.



Figure 1. The aerial photograph (A, left), and USGS topographic map (1:24,000) (B, right), of a section of the Huger Creek, Santee Experimental Forest, discussed in this paper. The black arrow in 1B points to the same point in Figure 2.

LIDAR data

LIDAR data for the SEF were obtained in 2006 by Photo Science, Inc. The LIDAR data were collected at a 2-m point spacing or better and gridded with a 1-m resolution and a vertical accuracy of 0.07–0.15 m. The bare-earth return data were processed in ARCGIS to smooth the digital elevation model (DEM) and map potential stream channels using the hydrology set (flow direction, length).

Results and Discussion

Detection of historical land use features

The LIDAR data was effective in delineating the drainage and agricultural water management features associated with the rice cultivation in the floodplain (Figure 2). The features range in size from dikes and dams (0.2–1.6 m height) to ditches (0.2–0.3 m depth). It is important to note the prominence of these features on the watershed and to realize that their occurrence is within a watershed that has a total relief of less than 4 m. Within the context of this landscape, these dikes and ditches are major topographic features. The only reflection of these historical agricultural water management features on the current USGS topographic map (scale 1:24,000) are the major impoundment structures (see Figure 1B), but only a few of those existing structures are denoted.

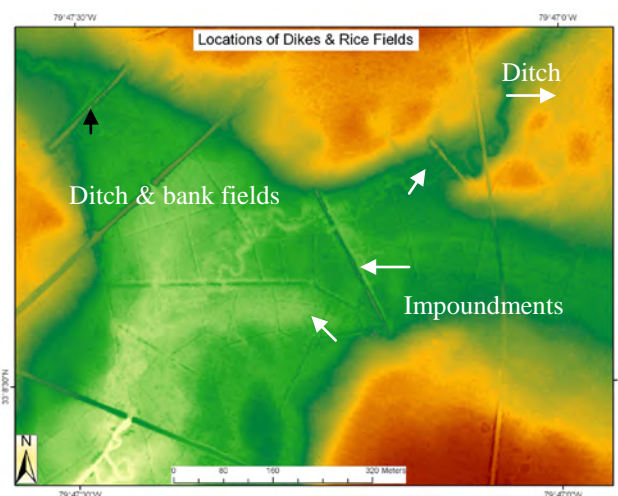

Figure 2. Depiction of surface topography derived from LIDAR data for a section of Huger Creek, Santee Experimental Forest. The location of some impoundments, ditches, and ditch and banked fields are noted.

In a similar application, James et al. (2007) used LIDAR data to map gullies and headwater streams under a forest canopy in South Carolina and found that LIDAR data provided robust detection of small gullies and channels, except where they are narrow or parallel and closely spaced. They reported that the ability of LIDAR data to map gullies and channels in a forested landscape should improve channel network maps and topological models.

Effects of historical water management features on watershed hydrology

The historical water management features are affecting current watershed hydrology in several ways. Diversion ditches are affecting upland runoff processes including overland flow paths. These ditches were constructed to shunt water from reservoirs to fields located in the floodplain; hence, they run perpendicular to the slope. The ditches, with the associated spoil bank, serve to interrupt surface runoff and to channel the runoff at points where water control structures existed (Figure 3). The presence of these features is a major contradiction to the assumptions of hill slope runoff from the traditional resource data. The effects of the collection and rechannelization are evident by drainage rivulets into the floodplain. The net effect of these ditches is to interrupt hillslope flow path and pool runoff and redirect it through small channels. It is also likely that subsurface runoff is also affected. This may also ultimately alter travel time and time to peak of flooding at the watershed outlet.

The old field ditches and banks also affect runoff within the floodplain; these are major topographic features that will affect transport and routing, especially during flood stages. During non-flood periods, if the old ditches are not hydraulically linked to the stream, they may function as detention storage areas affecting infiltration positively and stream flow negatively.

The LIDAR data also proved useful in delineating the stream location. The USGS topographic maps convey a rather straight or direct-flowing stream; in contrast, the stream generated with the LIDAR data illustrates a meandering channel (Figure 4). The difference in stream channel configuration between the two data sources is pronounced; for the stream

reaches denoted in Figure 4, the total channel length is 1,853 m on the USGS map and 2,981 m based on the LIDAR data.

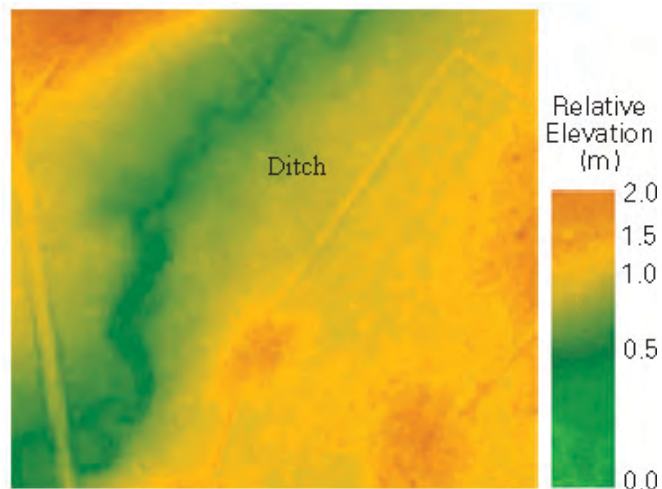

Figure 3. LIDAR image showing a stream diversion ditch running parallel to the present channel. The ditch and associated berm interrupt surface runoff.

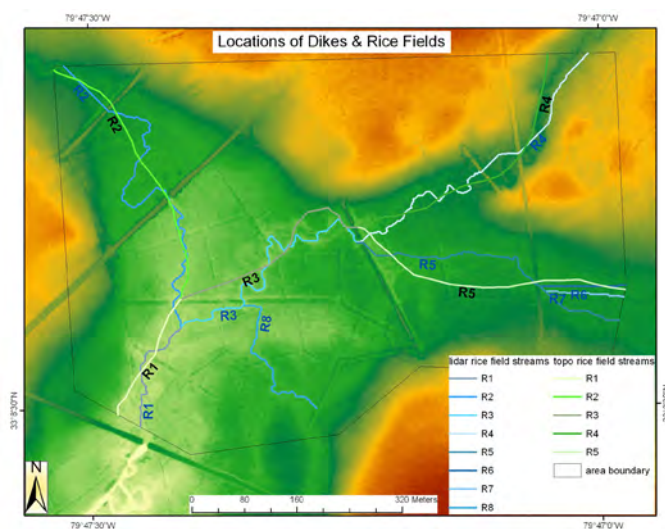

Figure 4. Overlay of the USGS topographic map (light green) and LIDAR-derived stream channel (blue).

Sinuosity, a ratio that describes whether a channel is straight or meandering, was also different when calculated with the USGS and LIDAR stream data (Table 1). None of the stream reaches would be considered meandering, a sinuosity ratio of 1.5 or greater, when calculated from the USGS topographic map. In contrast two of the stream reaches meander

when calculated from the LIDAR data. The 61-percent increase in channel length and recognition of sinuosity has important ramifications when considering peak discharge, time to peak, routing, and in-stream processes.

Table 1. Stream length and sinuosity for segments identified in Figure 4.

Reach	Stream length (m)		Sinuosity	
	USGS	LIDAR	USGS	LIDAR
R1	203.9	210.3	1.0	1.3
R2	432.3	692.6	1.1	1.6
R3	339.8	495.8	1.2	1.7
R4	438.2	562.7	1.1	1.2
R5	439.2	468.2	1.0	1.1
R6	N/A	130.3	N/A	1.0
R7	N/A	123.0	N/A	1.0
R8	N/A	279.2	N/A	1.4
Total	1853.4	2962.1		

Changes in hydrologic functions

Water management structures that were devised for rice cultivation in the floodplain that began 300 years ago are affecting contemporary surface water hydrology and stream channel hydraulics. As a result, hydrologic and hydraulic functions of the watershed have been altered from conditions that were presumed to exist in these now forested watersheds (Table 2). The changes are associated with alterations to hill slope runoff including its pathways, structures within the floodplain changing depressional storage, and increased channel length and flow routing, which results in longer time to peak and reduced peak runoff rate. While active water management structures increase surface depressional storage, enhancing the wetland hydrologic functions (e.g. water table elevations and soil moisture; Skaggs et al. 1994), it is uncertain how these relic structures affect depressional storage since the control structures are not functional.

Implications for modeling

When modeling hydrology on the SEF watershed, the landscape is represented by the readily available resource data (e.g. Figure 1). During model

calibration, parameters and coefficients may be modified to achieve reasonable simulations, as

Table 2. Effects of historical agricultural water management systems on hydrologic functions in floodplains of the Santee Experimental Forest.

Function	Rationale for altered functionality
Surface storage	Interruptions in overland runoff may retard the runoff rate and increase infiltration and ET.
Runoff routing	Interruptions in overland runoff effectively pool runoff and channelize the flow into the riparian zone.
Stream routing	Development of a meandering stream system following agricultural abandonment has resulted in longer flow path than represented on topographic maps.
Flood storage	Flood storage is likely increased with the presence of the dikes within the floodplain.
Water table depth	Longer surface water retention due to structures increase the water table elevation and soil moisture.

compared to measured stream discharge. As an example, a common parameter to adjust for peak flow rates during calibration is depressional storage, which is also a parameter that is very difficult to measure directly (Amoah 2008). It is evident that adjustments to depressional storage could mask or compensate for the effects of the actual channel and stream routing (Figure 4) and hill slope runoff (Figure 3). For example, depressional storage is a key parameter in the DRAINMOD model that controls the surface runoff rate after the soil is saturated and the surface storage is filled (Skaggs 1980, Konyha and Skaggs 1992, Haan and Skaggs 2003). The effect is to modify the model behavior to achieve more accurate output, but if that calibration does not reflect actual hydrological processes, then the end results do not reflect accurately simulated processes within the watershed. Recently, Amoah (2008) developed a geographic information system-based depressional storage capacity (DSC) model using USGS DEM data; for one of the SEF

watersheds (WS-77), he estimated 1 cm of effective depressional storage. When that storage factor was used to simulate stream discharge for the watershed using both DRAINMOD and its watershed-scale version, DRAINWAT (Amatya et al. 1997), Amoah (2008) found higher simulated peak flow rates by both models for the 2003–07 simulation period. That effect is likely due to an underestimation of the surface storage parameter for this watershed, which could result from not recognizing the historical water management structures that are not reflected in current DEMs.

Summary and Perspectives

There is a tremendous need to accurately represent environmental processes on the landscape. Questions involving climate change, land use effects, urbanization, etc. require a thorough understanding of the processes regulated by hydrology because the consequential thresholds are usually small. While models are the principal tool for conducting assessments, representations from spatially distributed, physically based models may only be as effective as the mathematical representation of the processes and the accuracy and resolution of the supporting data. We have shown that historical land use features may affect contemporary watershed hydrologic processes, to illustrate that the modeling process (e.g., calibration) may compensate for inherent features in the landscape. Adoption of higher resolution data, whenever available, will challenge and ultimately improve our understanding of hydrologic processes and hence model applications. In areas where water resources are critical and existing data relatively poor (e.g., coastal plain), acquisition of high resolution topographic data will greatly enhance our ability to assess hydrologic functions including water, nutrient, and carbon balances.

References

- Amatya, D.M., R.W. Skaggs, and J.D. Gregory. 1997. Evaluation of a watershed scale forest hydrologic model. *Agricultural Water Management* 32:239–258.
- Ambroise, B., J.L. Perrin, and D. Reutenauer. 1995. Multicriterion validation of a semidistributed conceptual model of the water cycle in Fecht catchment. *Water Resources Research* 31(6):1,467–1,481.
- Amoah, J. 2008. Development of a GIS-Based Tool for Estimating Surface Depressional Storage Coefficient for Application in Hydrologic Models. Florida A&M University, Civil and Environmental Engineering Department, Ph.D. dissertation, Tallahassee, FL.
- Haan, P.K., and R.W. Skaggs. 2003. Effects of parameter uncertainty on DRAINMOD predictions: Hydrology and yield. *Transactions of the American Society of Agricultural Engineers* 46(4):1,061–1,067.
- Hatterman, F., V. Krysanova, F. Wechsung, and M. Wattenbach. 2004. Integrating groundwater dynamics in regional hydrological modeling. *Environmental Modeling and Software* 19:1,039–1,051
- Hilliard, S.B. 1978. Antebellum Tidewater Rice Culture in South Carolina and Georgia. In James R. Gibson, ed., *European Settlement and Development in North America*, pp. 91–115. University of Toronto Press, Toronto.
- James, L.A., D.G. Watson, and W.F. Hansen. 2007. Using LIDAR data to map gullies and headwater streams under forest canopy: South Carolina, USA. *Catena* 71:132–144.
- Konyha, K.D., and R.W. Skaggs. 1992. A coupled, field hydrology–open channel flow model: Theory. *Transactions of the American Society of Agricultural Engineers* 35(5):1,431–1,440.
- Skaggs, R.W. 1980. A water management model for artificially drained soils. North Carolina State University, North Carolina Agricultural Research Service, Technical Bulletin No. 276, Raleigh, NC.
- Skaggs, R.W., D.M. Amatya, R.O. Evans, and J.E. Parsons. 1994. Characterization and evaluation of proposed hydrologic criteria for wetlands. *Journal of Soil and Water Conservation* 49(5):354–363.

Integrating Terrestrial LiDAR and Stereo Photogrammetry to Map the Tolay Lakebed in Northern San Francisco Bay

Isa Woo, Rune Storesund, John Y. Takekawa, Rachel J. Gardiner, Steve Ehret

Abstract

The Tolay Creek Watershed drains approximately 3,520 ha along the northern edge of San Francisco Bay.

Surrounded by a mosaic of open space conservation easements and public wildlife areas, it is one of the only watersheds in this urbanized estuary that is protected from its headwaters to the bay. Tolay Lake is a seasonal, spring-fed lake found in the upper watershed that historically extended over 120 ha. Although the lakebed was farmed since the early 1860s, the majority of the lakebed was recently acquired by the Sonoma County Regional Parks Department to restore its natural habitat values. As part of the restoration planning process, we produced a digital elevation model (DEM) of the historic extent of Tolay Lake by integrating terrestrial LiDAR (light detection and ranging) and stereo photogrammetry datasets, and real-time kinematic (RTK) global positioning system (GPS) surveys. We integrated the data, generated a DEM of the lakebed and upland areas, and analyzed errors. The accuracy of the composite DEM was verified using spot elevations obtained from the RTK GPS. Thus, we found that by combining photogrammetry, terrestrial LiDAR, and RTK GPS, we created an accurate baseline elevation map to use in watershed restoration planning and design.

Woo is a biologist, Takekawa is a wildlife research biologist, and Gardiner is an associate biologist, all at U.S. Geological Survey, Western Ecological Research Center, San Francisco Bay Estuary Field Station, Vallejo, CA 94592. Storesund is an engineer, Storesund Consulting, 555 Pierce Street #107B, Albany, CA 94706. Ehret is a park planner at Sonoma County Regional Parks Dept. 2300 County Center Drive, Suite 120A, Santa Rosa, CA 95403. Email: iwoo@usgs.gov.

Keywords: terrestrial LiDAR, photogrammetry, RTK GPS, restoration, digital elevation model

Introduction

The San Francisco Bay area is a highly urbanized region with approximately 80 percent of remnant wetlands lost to development and agriculture. One of the more uncommon wetland types in the bay is seasonal wetlands, which have declined by nearly 75 percent in the past 150 years (Olofson 2000). Seasonal wetlands are shallowly inundated after winter rains and dry up in the summer depending on seasonal water availability, site hydrology, substrate permeability, and topography. Accurate topographic data with appropriate spatial coverage is used for the design and engineering of seasonal wetland restoration or enhancements. Shallow, intermittently flooded lakes pose unique challenges for elevation surveys. Seasonal wetlands are often densely vegetated with submerged aquatic and tall emergent vegetation.

When inundated, echosounding systems modified for mapping shallow water bathymetry (Woo et al. 2007b; Athearn et al., in press; Takekawa et al., in press) would be suitable for measuring water depths; however, bottom elevations can be obscured by dense aquatic vegetation. Terrestrial or ground LiDAR is a recent alternative method for acquiring topographic data from areas where mobility and accessibility prohibit conventional surveying. Terrestrial LiDAR can be collected rapidly, is feasible for relatively small areas, and may be more accurate because of a greater point density than aerial LiDAR. Terrestrial LiDAR is ideal for unvegetated areas, but errors can increase with the amount of vegetation. Airborne LiDAR may be more appropriate in larger areas or areas with tall vegetative canopies, where vegetation signals may be

identified and filtered from bare ground by analyzing multiple laser returns (Heritage and Hethington 2006).

The restoration of Tolay Lake, a shallow seasonal lake that inundates private properties in addition to the park property, called for an accurate and detailed baseline topographic survey. We used a preexisting stereo photogrammetric dataset and filled data gaps using terrestrial LiDAR (light detection and ranging) and RTK GPS (real-time kinematic global positioning system). In addition, we created a digital elevation model (DEM) from the combined datasets and tested the accuracy of the DEM with spot checks from an RTK GPS receiver.

Site

The Tolay Creek watershed lies in the northern reaches of the San Francisco Bay Estuary and drains approximately 3,520 ha into the San Pablo Bay. This watershed is surrounded by a mosaic of open space, agriculture, conservation easements, public wildlife areas, and public lands that have been acquired for preservation and restoration. The Tolay Lake Regional Park, owned and managed by the Sonoma County Regional Parks, is located at the headwaters of the Tolay watershed in Sonoma County (lat: 38.205°, long: -122.520°). It encompasses 703 ha and composes 20 percent of the watershed.

The most significant feature of the park property is Tolay Lake. With a surface area of 80 ha, Tolay Lake is the largest natural freshwater lake in the San Pablo Bay watershed and ranges between 1.2 and 2.4 m deep (Kamman Hydrology and Engineering, Inc. 2003). Historically, Tolay Lake once had approximately twice the surface area (Kamman Hydrology and Engineering, Inc. 2003). In the mid-to-late 1800s a natural dam that created the lake was removed to facilitate farming of the lakebed, which supported various crops including pumpkins, squash, corn, potatoes, and tomatoes (Kamman Hydrology and Engineering, Inc. 2003). Tolay Lake drains into Tolay Creek, an ephemeral creek that is hydrologically disconnected from lower Tolay Creek, a 5-km reach that was restored to tidal flow from the bay in 1998. Managed by the San Pablo Bay National Wildlife Refuge and California Department of Fish and Game, the lower Tolay Creek wetland restoration project is highlighted as a successful restoration with long-term monitoring that shows recovery of tidal marsh inhabitants and wildlife species (Bias et al. 2006, Woo et al. 2007a). In 2004,

Sonoma County Regional Parks Department acquired the Tolay Lake Ranch in the upper watershed, and in 2007, the Sonoma Land Trust purchased 668 ha of the adjacent Roche Ranch that included a riparian easement along a 4-km stretch of Tolay Creek in the middle portions of the watershed. The connectivity of these landmark acquisitions resulted in the preservation of a majority of the Tolay watershed. Sonoma County identified a gap in their photogrammetric coverage located in the northwest section of the lakebed. We used terrestrial LiDAR and RTK GPS to fill data gaps and integrate the data into a combined DEM for the Tolay lakebed.

Methods

We initially planned to survey the lakebed with an echosounding system designed for shallow water applications (Woo et al. 2007b) combined with ground LiDAR surveys; however, because of dense vegetation growth and because relatively dry winter conditions precluded use of the echosounder, terrestrial LiDAR surveys were restricted. Therefore, we decided to integrate a preexisting photogrammetric dataset collected in 2005 for the Sonoma County Regional Parks (Delta Geomatics Corporation 2005). The dataset contained approximately 22,000 elevation points throughout the project area. The County identified a gap in the coverage for the northwest section of the lake that overlaid private property. We augmented and validated the photogrammetry dataset with RTK GPS spot elevations and terrestrial LiDAR (Figure 1).

Data are reported in the horizontal datum California State Plane NAD 83 Zone II (for comparisons with existing imagery) and orthometric heights were referenced to the vertical datum NAVD88 (U.S. survey feet) using the Geoid03 model (Leica GeoOffice v6.0). Data points were exported as shape files into ArcGIS (ESRI, Redlands, CA).

RTK MAX surveys

We used an RTK MAX GPS system to conduct the RTK surveys. The RTK MAX GPS surveys were primarily used to obtain validation elevation 'spot' checks. We conducted our surveys using a Leica RTK GPS (Smart Rover GPS 1200, Leica Geosystems Inc., Atlanta, GA) within the MAX network where RTK corrections were based on the Master Auxiliary Concept (Leica Geosystems 2008; Haselbach Surveying

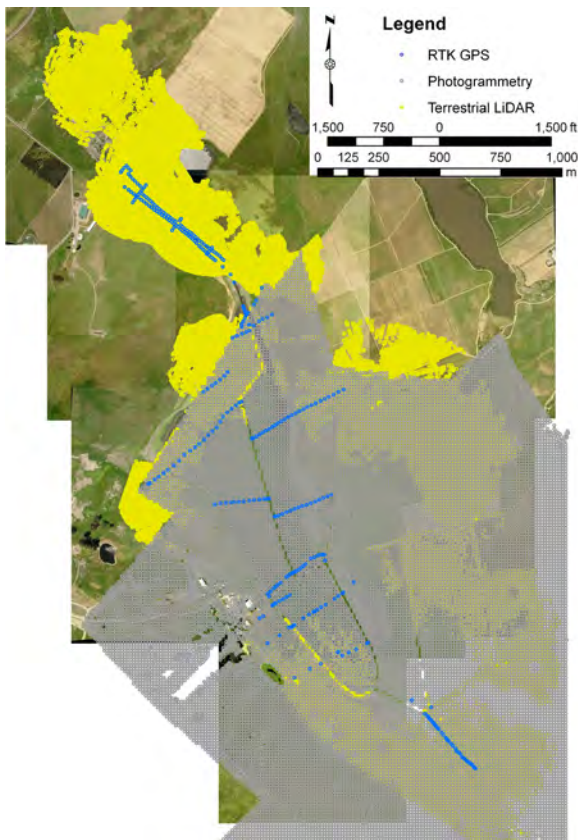

Figure 1. Locations of photogrammetry, terrestrial LiDAR, and RTK GPS elevation points throughout the Tolay Lake project area.

Instruments Inc., Burlingame, CA). Within the MAX network, the rover communicates with the reference station through cellular lines and monitors and changes its calculation of published algorithms in real time to optimize the RTK solution (Leica Geosystems 2008), yielding a real-time accuracy on the order of 2 cm (Brown et al. 2006, Ghilani and Wolf 2008). We used the reference station maintained by the City of Santa Rosa (2008) and collected 446 RTK GPS locations, of which 316 were used as spot validations in the channel, Tolay lakebed within the property, and the upper lakebed on private lands (for which we obtained written access permission).

Terrestrial LiDAR

We conducted 27 terrestrial LiDAR scans, 500 m apart, with an ISITE 4400CR laser unit on 22–23 March 2007. We used an RTK GPS to survey the LiDAR unit setup and back sight locations. These setup locations were used to georeference the LiDAR point clouds during data processing. The laser scanner used a time-

of-flight pulsed range finder with a 905-nm laser and a beam divergence of 1.4 mrad. The unit has a built-in tilt compensator that ensures each scan is level prior to initiation of the scan. It has a measurement rate of 4,400 points per second and a scan range of <3 m to >250 m. Point clouds produced from each scan were aligned, visualized, and processed using ISITE Studio software v 3.0 beta, (I-Site Pty Ltd, Glenside, South Australia). We filtered out vegetation height by applying a 1.5-m topographic filter in which only the lowest point within 1.5 m² was retained for analyses, yielding 395,000 filtered data points. We examined differences between the LiDAR scans and RTK GPS ground elevations that were within 2 m of each other. The LiDAR elevations were 0.58 ± 0.03 m higher than the RTK ground elevations. We further adjusted for vegetation interference by subtracting 0.58 m from the LiDAR datasets because of the small standard error and the uniformity of the grassy vegetation understory in the upper lakebed.

Digital elevation model and validation

We integrated the photogrammetry and terrestrial LiDAR datasets. Values between data points were interpolated using inverse distance weighting (IDW) in ArcGIS (Spatial Analyst, Geostatistical Analyst, ESRI). IDW is an exact interpolator in that the maximum and minimum values in the interpolated surface can only occur at sample points. This method assumes that the surface is being driven by local variation and is appropriate for points that are evenly distributed (Johnston et al. 2001). The DEM was generated with grid cell size of 10 m because of the high point density (Spatial Analyst, ArcGIS; Figure 2).

[Continued on next page]

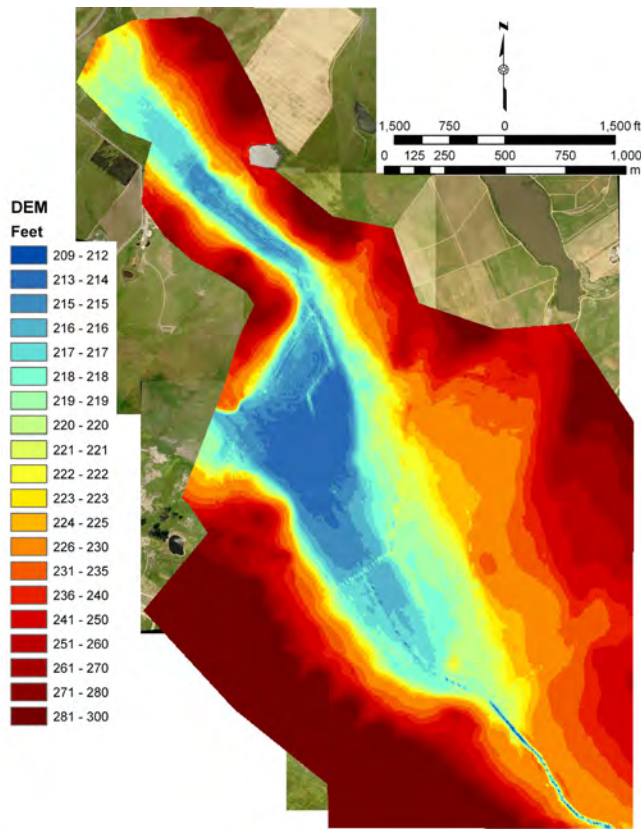

Figure 2. Composite digital elevation model using photogrammetric and terrestrial LiDAR datasets.

We analyzed model errors with the surface spot tool (3D Analyst, ArcGIS, ESRI), where we compared actual RTK GPS point values to the respective locations on the predicted elevation model. We calculated the errors (standard error, standard deviation, root mean square error ($RMSE_z$)) and the vertical accuracy within a 95-percent confidence interval for the entire dataset and by habitat type (channel, Tolay lakebed, upper lakebed; Flood 2004, Aguilar and Mills 2008).

Root mean squared error ($RMSE_z$) is calculated by:

$$RMSE_z = \frac{\sqrt{\sum_{i=1}^n (z_{1i} - z_{2i})^2}}{n} \quad (1)$$

Vertical accuracy within 95-percent confidence interval is calculated by:

$$\text{Vertical accuracy at 95\% CI} = RMSE_z \times 1.96 \quad (2)$$

Where

Z_{1i} is the vertical coordinate of the i^{th} check point in the dataset,

Z_{2i} is the vertical coordinate of the i^{th} check point in the independent data source of higher accuracy,

n is the number of points being checked,

and

i is an integer from 1 to n .

Results and Discussion

We gathered 446 elevation points with the RTK GPS, of which 316 points were used for validation with the surface spot tool. The RTK GPS locations in the Tolay lakebed and upper lakebed had little topographic variation (Tolay lakebed: mean + se; 216.39 + 0.21 ft; upper lakebed: 215.98 + 0.06 ft. Channel areas had greater variation (212.17 + 0.39 ft) due to tall vegetation near the channel edge.

Digital elevation models consist of errors from field accuracy and errors from data interpolation in elevation models. We found that the interpolated points on the DEM matched the RTK GPS validation points well with a mean difference of 0.06 ± 0.07 ft (Table 1). The $RMSE_z$ was 0.07 ft and the consolidated vertical accuracy (at a 95-percent confidence interval) was 0.13 ft, much more than other reported values for low vegetation such as crops (range 1.15–1.51 ft; Veneziano et al. 2003).

When examined by habitat type, channels had the greatest error (1.84 ± 0.30 ft), compared to the Tolay lakebed (0.10 ± 0.05 ft) and upper lakebed (0.63 ± 0.05 ft; Table 1). The DEM predicted channel elevations nearly 2 ft higher than actually measured, likely a result of the narrow and linear feature of the channel and because the channel ridges and bottoms were obscured by tall vegetation or water, respectively.

Although the Tolay lakebed and surrounding hillsides had grassland and weedy vegetative cover that were not ideal conditions for terrestrial LiDAR, the survey produced accurate elevations with a high density of point coverage. Combined with existing data, the resulting DEM met accuracy standards for the

restoration design. The DEM needs to be ground truthed and validation results reported for each major habitat classification. These values give the user an idea of accuracy of the field data and in the interpolation between points within the selected DEM.

Table 1. Mean error differences and 95-percent confidence interval between the predicted digital elevation model and actual RTK GPS ground points (by overall area, channel, Tolay lakebed, and upper lakebed areas) using surface spot tool (3D Analyst, ArcGIS, ESRI).

[SE, standard error; SD, standard deviation; CI, confidence interval]

Area	Mean	Error (ft)			95% CI
		SE	SD	RMSE _z	
Overall	0.06	0.07	1.16	0.07	0.13
Channel	-1.84	0.30	1.92	0.41	0.81
Lakebed	0.10	0.05	0.61	0.05	0.10
Upper lakebed	0.63	0.05	0.53	0.07	0.14

Conclusions

We found that merging terrestrial LiDAR surveys with available topographic information was effective in filling topographic data gaps, especially in areas with limited physical access. The overall composite DEM had a mean error of about 2 cm, with a consolidated vertical accuracy of 4 cm. We also found that “ground truthing” with the RTK MAX GPS provided an excellent means by which to validate the DEM.

Terrestrial LiDAR methods to determine ground elevations are ideal in bare areas because vegetation signals may not be entirely filtered out; however, this method may also be well-suited for examining vegetation structure and characterizing habitat (Vierling et al. 2008), similar to the use of airborne LiDAR to examine canopy structure and heterogeneity for wildlife (Bradbury et al. 2005, Goetz et al. 2007). Tidal marsh inhabitants face numerous threats (Takekawa et al. 2006) including sea level rise. High marsh to upland transition zones often exist as narrow, linear bands along levees, such that during extreme

floods, animals are forced to travel upland or up tall vegetation for cover, where they may become exposed to predation (Evens and Page 1986). Long-term monitoring at lower Tolay Creek showed a precipitous decline in small mammal captures, including the endangered salt marsh harvest mouse (*Reithrodontomys raviventris*), following extreme winter tides and floods (Woo et al. 2007a; Woo, unpub. data). Terrestrial LiDAR may be particularly useful in characterizing the vegetative canopy of upland transition zones as extreme high tide refugia habitat (Woo et al. 2007a).

Acknowledgments

The authors appreciate the reviews of William Perry and Steve Carroll. This study was supported by Sonoma County Regional Parks Department and U.S. Geological Survey, Western Ecological Research Center, San Francisco Bay Estuary Field Station, Wetland Restoration Program. Delta Geomatics Corporation conducted the stereo photogrammetry. We also thank biological science technicians (WERC) Ariel Rowan, Lindsay Dembosz, and Eric Palm; Hans Haselbach (Haselbach Surveying Instruments) for GPS assistance; and Dr. Schaller and David Martinelli provided permission for property access to conduct the survey.

References

- Aguilar, F.J., and J.P. Mills. 2008. Accuracy assessment of Lidar-derived digital elevation models. *The Photogrammetric Record* 23(122):148–169.
- Athearn, N.D, J.Y. Takekawa, B. Jaffe, B. Hattenbach, and A.C. Foxgrover. In press. Mapping bathymetry of tidal wetland restoration sites in San Francisco Bay: Comparing accuracy of aerial LiDAR with a singlebeam echosounder. *Journal of Coastal Research*.
- Bias, M.A., J.Y. Takekawa, I. Woo, and R. Gardiner. 2006. Ecological monitoring of Tolay Creek and Cullinan Ranch tidal wetland restoration projects in the North San Francisco Bay: Final report. Unpublished Report to CALFED, Sacramento, CA, CALFED 01-N19.
- Bradbury, R.B., R.A. Hill, D.C. Mason, S.A. Hinsley, J.D. Wilson, H. Balzter, G.Q.A. Anderson, M.J. Whittingham, I.J. Davenport, and P.E. Bellamy. 2005. Modelling relationships between birds and vegetation

- structure using airborne LiDAR data: A review with case studies from agriculture and woodland environments. *Ibis* 147:443–452.
- Brown, N., L. Geisler, and L. Troyer. 2006. RTK Rover performance using the master-auxiliary concept. *Journal of Global Positioning Systems*. 5(1–2):135–144.
- City of Santa Rosa. 2008. GPS base station: Real time GPS data. City of Santa Rosa, CA, Public Works Department. [online] URL: <http://ci.santa-rosa.ca.us/departments/publicworks/survey/Pages/GPS.aspx>. Accessed 9 June 2009.
- Delta Geomatics Corporation. 2005. Tolay Lake Regional Park: Photogrammetry dataset. Produced for the Sonoma County Regional Parks Department, CA.
- Evens, J., and G.W. Page. 1986. Predation on black rails during high tides in salt marshes. *Condor* 88:107–109.
- Flood, M. 2004. ASPRS Lidar Guidelines: Vertical Accuracy Reporting for Lidar Data, ver. 1. American Society for Photogrammetry and Remote Sensing, Lidar Committee.
- Ghilani, C.D., and P.R. Wolf. 2008. *Elementary Surveying: An Introduction to Geomatics*, 12th ed. Prentice Hall, New Jersey.
- Goetz, S., D. Steinberg, R. Dubayah, and B. Blair. 2007. Laser remote sensing of canopy heterogeneity as a predictor of bird species richness in an eastern temperate forest, USA. *Remote Sensing of Environment* 108:254–263.
- Heritage, G., and D. Hetherington. 2006. Towards a protocol for laser scanning in fluvial geomorphology. *Earth Surface Processes and Landforms* 32(1):66–74.
- Johnston, K., J.M. Ver Hoef, K. Krivoruchko, and N. Lucas. 2001. *Using ArcGIS Geostatistical Analyst*. ESRI, Redlands, CA.
- Kamman Hydrology and Engineering, Inc. 2003. *Hydrologic Feasibility Analysis for the Tolay Lake Ranch Property, Sonoma County, California*. Prepared for Sonoma County Agricultural Preservation and Open Space District.
- Leica Geosystems. 2008. RTK networks. Part 2: The different methods. Leica Geosystems, Surveying and Engineering Division, System 1200 Newsletter No 53.
- Olofson, P.R., ed. 2000. *Baylands Ecosystem Species and Community Profiles: Life Histories and Environmental Requirements of Key Plants, Fish, and Wildlife*. Prepared by the San Francisco Bay Area Wetlands Ecosystem Goals Project. San Francisco Bay Regional Water Quality Control Board, Oakland, CA.
- Takekawa, J.Y., I. Woo, H. Spautz, N. Nur, J.L. Grenier, K. Malamud-Roam, J.C. Nordby, A.N. Cohen, F. Malamud-Roam, and S.E. Wainwright-De La Cruz. 2006. Environmental threats to tidal marsh vertebrates in the San Francisco Bay estuary. *Studies in Avian Biology* 32:176–197.
- Takekawa, J.Y., I. Woo, N.D. Athearn, S.A. Demers, R.J. Gardiner, W.M. Perry, N.K. Ganju, G.G. Shellenbarger, and D.H. Schoellhamer. In press. Measuring sediment accretion in early tidal marsh restoration. *Wetlands Ecology and Management*.
- Veneziano, D., S. Hallmark, and R. Souleyrette. 2003. Integration of light detection and ranging technology with photogrammetry in highway location and design. *Transportation Research Record* 1836:1–6. Paper No. 03-2908.
- Vierling, K.T., L.A. Vierling, W.A. Gould, S. Martinuzzi, and R.M. Clawges. 2008. Lidar: Shedding new light on habitat characterization and modeling. *Frontiers in Ecology and the Environment* 6(2):90–98.
- Woo, I., J.Y. Takekawa, R. Gardiner, G.T. Block, and M.A. Bias. 2007a. Assessing restoration outcomes: Eight years of progress at Tolay Creek. *The Wildlife Society*, Monterey, CA, February 2007, Presentation.
- Woo, I., J.Y. Takekawa, A. Rowan, R. Gardiner, O. Bernstein, and G.T. Block. 2007b. *The Tubbs Setback Restoration Project: Early restoration progress*. U.S. Geological Survey, Final administrative report to U.S. Fish and Wildlife Service. Vallejo, CA.

Does Climate Matter? Evaluating the Effects of Climate Change on Future Ethiopian Hydropower

Paul Block, Casey Brown

Abstract

This research aims at quantifying the effect and importance of considering future climate change on large-scale infrastructure in a developing country context. Plans are underway for major hydropower development in Ethiopia, a water resources-rich nation, yet consideration of climate change on design, operation, and eventual benefits of the system remains uncharted. If current strategies are reliant on stationary climate, what future climatic conditions could warrant measurable design changes or even project abandonment? How much do long-term benefits change, and is this level significant, especially considering economic variability, policy, and other competing demands? A vacuum currently exists for decisionmakers; there is clear recognition that climate change information ought to be considered but little experience in incorporating the seemingly complex science into design and operational decisions. This research aims to establish and demonstrate an approach for integrating climate change information into project evaluation, ultimately creating a serviceable format from which scientists outside of the climate specialty may address climate risk management decisions. To model the system, potential future precipitation and temperature trends are utilized to drive a coupled hydrology–Ethiopian hydropower optimization model, producing project benefit-cost ratios over 50 years. These results are subsequently evaluated through benefit-cost ratio surface illustrations for varying economic, policy, and project scope conditions. Preliminary results suggest nonstationary climate influences may warrant economic attention in

Block is an associate research scientist, International Research Institute for Climate and Society (IRI), Columbia University, Palisades, NY 10964. Brown is an assistant professor of civil and environmental engineering, University of Massachusetts, Amherst, MA 01003. Email: pblock@iri.columbia.edu; cbrown@ecs.umass.edu.

comparison with traditionally dominant factors. Additionally, drier than historically normal conditions appear to have a greater detrimental effect on overall benefit-cost ratios than positive effects expected under wetter than normal conditions, a constructive conclusion for early project planning and design.

Keywords: climate, climate change, decisionmaking, water resources, hydropower, risk management, Ethiopia

Introduction

Weather and climate are inherently uncertain, rendering appropriate water resources planning and management anything but deterministic. Seasonal to interannual forecasts attempt to characterize and reduce operational and design uncertainty, but as the forecast or projection horizon is extended, uncertainty invariably grows (Enfield and Cid-Serrano 2006). Given the extraordinary attention that climate change has received recently, few water resources managers (or public citizens) remain unaware. There is clear recognition that climate change information ought to be considered, but little experience with how to incorporate the seemingly complex science into design and operational decisions. This vacuum gives rise to the question of how to assess existing or future projects given the current level of climate change knowledge and uncertainty. Is climate change indeed significant and influential enough to warrant a fully inclusive analysis, or is designing according to classical principals and methodologies still suitable? How does one decide, especially given associated changes in population, economics, policies, and preferences (James et. al 1969)? If climate change does appear to be sufficiently influential, how can the associated impacts be incorporated into operations or design? Significant research activity has focused on appropriate water resources assessment and adaptation strategies in relation to climate change uncertainties (Carter et. al 1994, Rogers 1997, Frederick 1998, Fankhauser et. al

1999, Adger et. al 2003). This study builds on that work and begins to address these critical questions, proposing one approach in the context of hydropower design within Ethiopia for 2001–2050. While it is clear that the spatial variability of climate change projections requires a unique analysis for each project in each geographical region, it is anticipated that the methodology and assessment tools proposed here would be fully transferable.

Application Site

In 1964, the United States Bureau of Reclamation (USBR), upon invitation by the Ethiopian government, performed a thorough investigation and study of the hydrology of the upper Blue Nile basin, coincident with construction of the Aswan High Dam in Egypt (1960–1970). Included in the USBR’s study was an optimistic list of potential projects within Ethiopia, including preliminary designs of dams for irrigation and hydroelectric power along the Blue Nile and Atbara Rivers. The four major hydroelectric dams along the Blue Nile, as proposed by the USBR, are presented in Figure 1. Operating in tandem, these four dams would impound a total of 73.1 billion cubic meters, which is equivalent to approximately 1.5 times the average annual runoff in the basin. The total installed capacity at design head would be 5570 megawatts (MW) of power, about 2.5 times the potential of the Aswan High Dam in Egypt and capable of providing electricity to millions of homes. This would be an impressive upgrade over the existing 529 MW of hydroelectric power within Ethiopia as of 2001 (Thomson 2006).

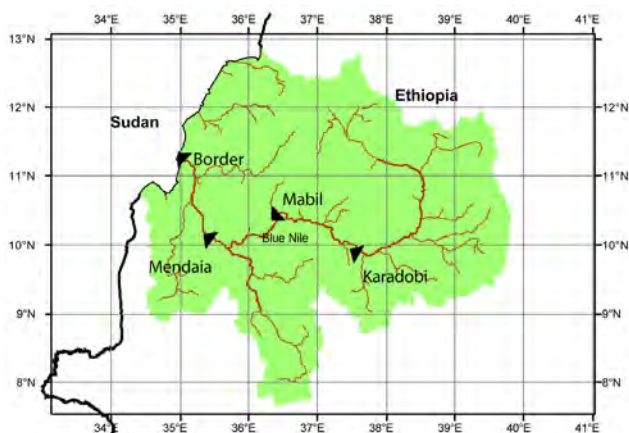

Figure 1. Plan view of proposed hydroelectric dams along the Blue Nile River, as proposed by the United States Bureau of Reclamation.

To this point in time, no dam designs have moved beyond the feasibility stage for a variety of political and financial reasons. Models and evaluations in this study incorporate proposed plans only, limiting the analysis to two or three dams.

Methodology

To address potential climate change influences on the proposed Ethiopian hydroelectric dams, several models and algorithms are necessary, coupled in an iterative fashion, as illustrated in Figure 2.

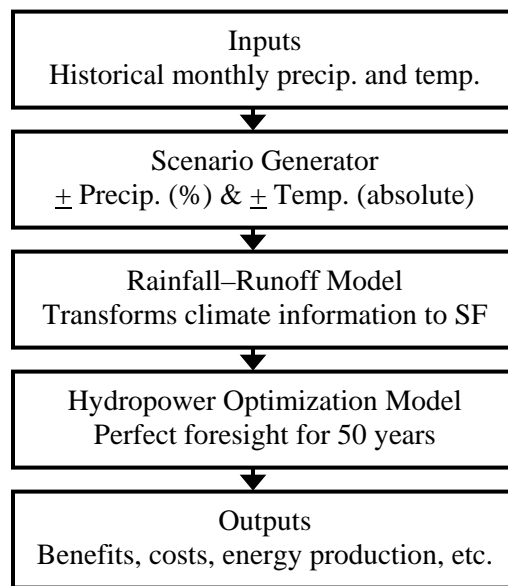

Figure 2. Coupled models required for climate change analysis on proposed Ethiopian hydroelectric dams. SF, streamflow.

The overall structure is not dissimilar from customary static approaches to project/operational design and evaluation. The process is driven with (traditionally historic) climate data then optionally forced through a scenario generator if multiple or trend-added projections are desired. For future nonstationary climate scenarios, the generator imposes prescribed precipitation (e.g. +10 percent) and temperature (e.g. +1°C) changes on top of the actual historic climate data. The synthetic climate scenarios are subsequently imposed on a rainfall-runoff model to produce streamflow (SF) values and evapotranspiration at reservoir inflow points, which in turn drive the hydropower model. Final outputs include project benefits, costs, energy production, reservoir levels, etc.

For the specific projects considered here, the historical monthly climate data were extracted from the University of East Anglia Climate Research Unit's datasets for 1951–2000 (New et al. 1999, Mitchell et al. 2004). Analysis of climate change influences are evaluated monthly over 2001–2050 with varying combinations of potential precipitation (+20, +10, 0, -10, and -20 percent) and temperature (+1°C, +2°C, +3°C) changes for a total of 15 scenarios. Changes are applied in a linear gradient manner; using the temperature (+1°C) and precipitation (0 percent) example, temperature changes in 2001 are essentially equivalent to 1951, but are one full degree higher in 2050 than the historical 2000 value.

The 0.5° x 0.5° gridded rainfall-runoff model CLIRUN2, a derivative of the WatBal model (Yates 1996; Strzepek, 2007, personal commun.), is employed here. CLIRUN2 is a lumped basin, two-bucket model running on monthly time steps, calibrated to historical streamflow at Roseires, Sudan, as available from the National Center for Atmospheric Research (Bodo 2001).

The hydropower model IMPEND (Block and Strzepek, in press) is utilized to model climate influences on potential hydroelectric dams along the Blue Nile River between its inception at Lake Tana, Ethiopia, and Roseires, Sudan, just beyond the Sudan-Ethiopia border. IMPEND is a perfect foresight water resources system optimization model in which dams are constructed and brought online in predefined stages (every seven years in this study). IMPEND is also sufficiently flexible to address both policy and economic influences, especially relevant here for comparison with climate change impacts. Policy influences are characterized by the quantity of streamflow that may be impounded because of anticipated regulations by downstream countries. This is especially critical in the early reservoir filling stages. Total reservoir impoundment is limited here to either 5 or 10 percent of the annual total. Economic influences are portrayed through varying discount rates, static throughout the 50-yr simulation, of 5, 10, or 15 percent.

Although many output variables are of interest for additional analysis, only benefits (B) and costs (C) will be discussed further. Both represent totals over the 50-yr simulation period, discounted back to 2000 US dollars and typically presented as a ratio (B/C ratio).

Results and Discussion

Table 1 presents B/C ratios for development and operation of two dams for 2001–2050, including base (actual 1951–2000 values) and potential climate change conditions, for varying flow policies and discount rates. As anticipated, increases in temperature and declines in precipitation result in lower overall B/C ratios, likewise with rising discount rates and smaller flow policies. The perfect foresight aspect of the hydropower model contributes to the relatively linear trends between scenarios and also represents the highest (unrealistically) attainable B/C ratio. Clearly, under the assumptions established here, if discount rates are at or above 15 percent, the project is unlikely to reach a break-even point. Another point of interest is that temperature increases have little to no effect. This may be predominantly explained away by minimal reservoir surface area (water simply backs up in the channel as opposed to spreading out laterally) and the restrictive flow policies.

To further address the question of whether or not climate change is sufficiently influential on this project and thus warrants a more detailed analysis, Table 1 may be cast into illustrations of B/C ratio surfaces for interpretive purposes. Figure 3 demonstrates the ensuing surface for a flow policy equal to 5 percent and discount rate of 10 percent.

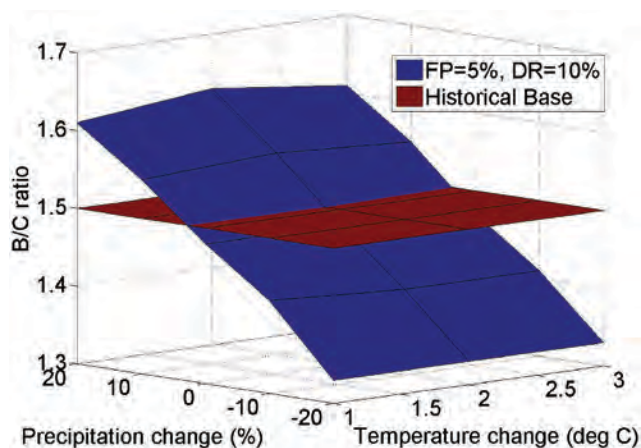

Figure 3. Surface plot of B/C ratios for varying precipitation and temperature changes under a flow policy (FP) of 5 percent and discount rate (DR) of 10 percent (blue). Historical base illustrated as a surface for comparison (red).

For comparison, the base case, also discounted at a 10 percent rate, but assuming no changes in climate, has been displayed as a surface (although it is in actuality a point).

Table 1. Benefit-cost ratios for development of two dams for 2001–2050 discounted to 2000 US dollars.

T, P scenario	Flow Policy = 5%			Flow Policy = 10%		
	DR=5%	DR=10%	DR=15%	DR=5%	DR=10%	DR=15%
historical base	3.12	1.50	0.81	3.51	1.61	0.97
1°, +20%	3.51	1.61	0.86	3.88	1.87	1.02
1°, +10%	3.33	1.55	0.84	3.70	1.81	1.00
1°, 0%	3.12	1.48	0.81	3.47	1.73	0.97
1°, -10%	2.93	1.42	0.79	3.29	1.67	0.94
1°, -20%	2.70	1.33	0.75	3.05	1.58	0.90
2°, +20%	3.55	1.63	0.87	3.92	1.89	1.03
2°, +10%	3.35	1.56	0.84	3.72	1.81	0.99
2°, 0%	3.14	1.48	0.81	3.50	1.74	0.96
2°, -10%	2.92	1.41	0.78	3.28	1.67	0.93
2°, -20%	2.70	1.33	0.75	3.05	1.58	0.90
3°, +20%	3.53	1.61	0.88	3.92	1.89	1.03
3°, +10%	3.32	1.55	0.84	3.71	1.81	1.00
3°, 0%	3.11	1.47	0.81	3.48	1.73	0.97
3°, -10%	2.89	1.41	0.78	3.25	1.65	0.93
3°, -20%	2.67	1.33	0.75	3.03	1.57	0.90

T = temperature, P = precipitation, DR = discount rate

Clearly, as precipitation changes between scenarios, the B/C ratios follow suit. To what degree they change may potentially be critical for planning or redesign purposes. For example, equivalent positive and negative changes in precipitation do not necessarily produce identical changes in the B/C ratio. Given this scenario, if precipitation increases, B/C ratios may elevate by as much as 0.1; having a sense of this a priori is obviously beneficial. Equally important, however, is caution in considering drier conditions for which the B/C ratio may decline by nearly 0.2. Given the economic value of a B/C ratio change (0.2 equates to approximately \$550 million US for this example), decisionmakers may be better informed as to whether this constitutes sufficient grounds for further climate change analysis as it pertains to the project.

Project feasibility may also be preliminarily assessed in similar fashion. Figure 4 presents the B/C ratio surface for a flow policy equal to 10 percent and discount rate of 15 percent. A planar surface for a B/C ratio equal to one is also displayed to represent the project break-even point.

Although relatively simplistic at this stage, ignoring external feedbacks which may ultimately boost the

overall project returns, and also applying a perfect foresight approach that likely overestimates returns, the surface still serves as a first-order project turning point for decisionmaking. Clearly, only in wetter conditions does the project appear to be viable, and then only minimally, whereas for historically normal and drier conditions, the risk of lower returns increases.

Sensitivity analyses of policies and economic metrics are also possible through this illustrative approach. Figures 5 and 6 compare across discount rates and flow policies, respectively, for varying climate change conditions.

Figure 5 shows a clear distinction between discount rates and the effects of doubling or tripling them. More interestingly, however, is comparing the general slopes of the surfaces. An interpretation of the 15 percent discount rate may be that no additional climate change analysis is necessary, as the surface has little slope and appears relatively uninfluenced. Alternatively, the 5 percent discount rate surface portrays a relatively steeper surface crossing a larger range of B/C ratios, so a more thorough climate change analysis may be justified.

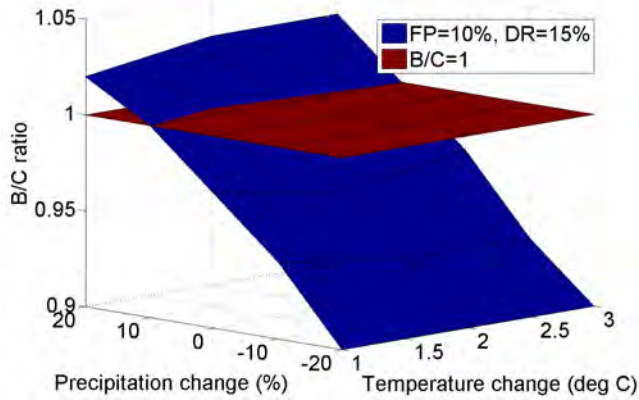

Figure 4. Surface plot of B/C ratios under a flow policy (FP) of 10 percent and discount rate (DR) of 15 percent (blue). B/C ratio equal to 1 illustrated for comparison (red).

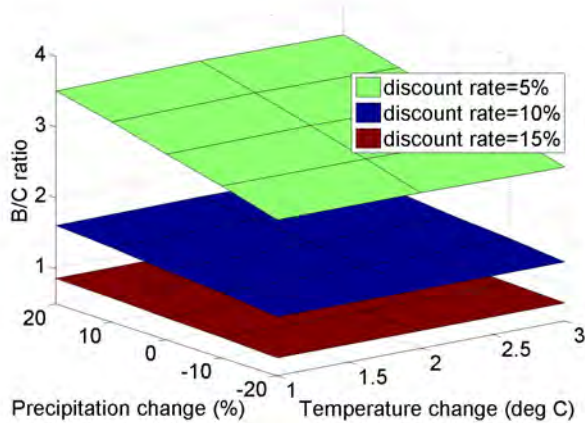

Figure 5. Surface plots of varying discount rates for the 5 percent flow policy.

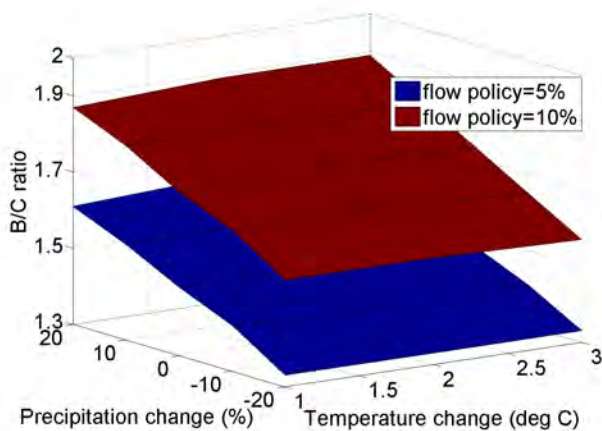

Figure 6. Surface plots of varying flow policies for a 10 percent discount rate.

A plausible interpretation of Figure 6 as related to the necessity of further climate change analysis may be that although both policies appear to be relatively equally affected to changes (similar slopes), the 10 percent policy B/C ratio under the driest conditions is still nearly on par with the best expected B/C ratio under the 5 percent policy. Obviously externalities (e.g. remuneration to downstream countries) become increasingly important and ultimately need to be factored in, but simply understanding the plausible outcomes over a range of conditions may be exceptionally informative.

Comparing B/C ratio surfaces is also revealing for evaluating competing projects under similar conditions. Figure 7 illustrates projects for development and operation of both two and three dams under a 10 percent flow policy and a 5 percent discount rate.

The two projects perform similarly across varying climatic conditions; however, from a B/C ratio perspective, it may be advantageous to select the two-dam option under drier conditions and the three-dam option under wetter conditions.

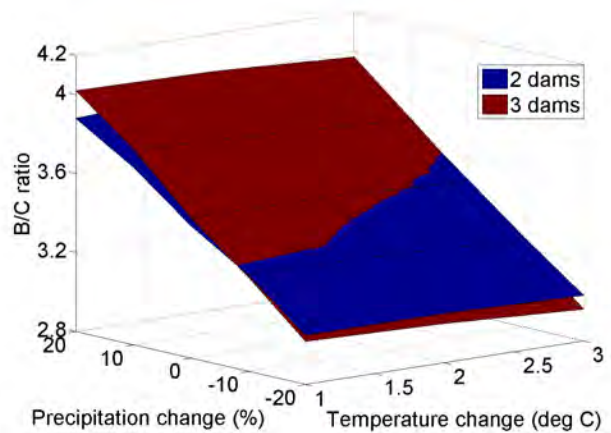

Figure 7. Surface plots for development and operation of two and three dams under a flow policy of 10 percent and discount rate of 5 percent.

Conclusions

This research aims to establish and demonstrate an approach for integrating climate change information into project evaluation, ultimately creating a serviceable format from which scientists outside of the climate specialty may address climate risk management decisions. Appraisal of long-term benefits under climate change assists in establishing climate

significance and whether a fully inclusive analysis is warranted, especially considering economic variability, policy, and other competing demands. A coupled hydrology–Ethiopian hydropower model is driven by potential climate changes in precipitation and temperature to produce project benefit-cost ratios over 50 years. The B/C ratios are transformed into surface illustrations to assess and compare climate change influences on single or multiple projects. Surface interpretation indicates that drier than historically normal conditions appear to have a greater detrimental effect on overall B/C ratios than the positive effect under wetter than normal conditions. Project outcomes under large discount rates are relatively unaffected by climate change influences, while smaller rates point toward greater potential variability. A doubling of the allowable rate of streamflow impoundment produces decidedly higher B/C ratios throughout the range of climate changes explored.

Although a range of climate change scenarios are explored, a more complete assessment is likely justified through a probabilistic evaluation of historical conditions. In this study, the actual 1951–2000 monthly conditions are repeated in sequence with climate changes imposed on top. Alternatively, an ensemble of 50-yr sequences generated from the 1951–2000 record could be used as starting points to develop multiple plausible B/C ratios for each precipitation and temperature combination. This would effectively give thickness to the surfaces.

Surface illustrations alone may not be sufficient for final decisionmaking, but they begin to give a sense of the influence of climate change independently and in comparison to other factors (policy and economics). Priorities and beliefs as to how future climate may evolve play a critical role in final project appraisal. If the assumption exists that all potential climate change scenarios presented here are equally likely, effectively weighting each scenario uniformly, the surfaces can be interpreted as if in a probability space, and the overall expected B/C ratio is simply an average of the entire surface. However, if some scenarios are believed to be more likely, they may be given a higher weight, skewing the overall expected B/C ratio away from the surface mean. Rationales for weighting scenarios differently may develop from local knowledge or trends, global climate model or Intergovernmental Panel on Climate Change projections, or other sources. Quantifying these weights and applying them to the B/C ratio surfaces is an ongoing piece of research.

Acknowledgments

The authors appreciate the reviews of Dr. Alyssa McCluskey and Dr. Pietro Ceccato.

References

- Adger, W.N., S. Huq, K. Brown, D. Conway, and M. Hulme. 2003. Adaptation to climate change in the developing world. *Progress in Development Studies* 3:179–195.
- Block, P., and K. Strzepek. In press. Economic analysis of large-scale upstream river basin development on the Blue Nile in Ethiopia considering transient conditions, climate variability, and climate change. *Journal of Water Resources Planning and Management*.
- Bodo, B. 2001. Monthly discharge data for world rivers. University Corporation for Atmospheric Research, Computational and Information Systems Library. [online] URL: dss.ucar.edu/datasets/ds552.1. Accessed 1 July 2008.
- Carter, T.R., M.L. Parry, H. Harasawa, and S. Nishioka. 1994. IPCC Technical Guidelines for Assessing Climate Change Impacts and Adaptations. University College London, Department of Geography, London, U.K.
- Enfield, D.B., and L. Cid-Serrano. 2006. Projecting the risk of future climate shifts. *International Journal of Climatology* 26(7):885–895.
- Fankhauser, S., J.B. Smith, and R.S.J. Tol. 1999. Weathering climate change: Some simple rules to guide adaptation decisions. *Ecological Economics* 30(1):67–78.
- Frederick, K.D. 1998. Principles and concepts for water resources planning under climate uncertainty. *Water Resources Update*, Summer:41–46.
- James, C., B.T. Bower, and N.C. Matalas. 1969. Relative importance of variables in water resources planning. *Water Resources Research* 5(6):1,165–1,173.
- Mitchell, T., T. Carter, P. Jones, M. Hulme, and M. New. 2004. A comprehensive set of high-resolution grids of monthly climate for Europe and the globe: The observed record (1901–2000) and 16 scenarios (2001–2100). Tyndale Center for Climate Change Research, Working Paper 55, Norwich, U.K.

New, M., M. Hulme, and P.D. Jones. 1999. Representing twentieth century space-time climate variability. Part 1: Development of a 1961–90 mean monthly terrestrial climatology. *Journal of Climate* 12:829–856.

Rogers, P. 1997. Engineering design and uncertainties related to climate change. *Climatic Change* 37:229–242.

Thomson, G. 2006. *Encyclopedia of the Nations: Africa*. Gale Cengage, Farmington Hills, MI.

Yates, D. 1996. WatBal: An integrated water balance model for climate impact assessment of river basin runoff. *International Journal of Water Resources Development* 12(2):121–139.

Publishing support provided by:
Denver Publishing Service Center

For more information concerning this publication, contact:
Chief, Branch of Regional Research, Central Region
Box 25046, Mail Stop 418
Denver, CO 80225
(303) 236-5021

Or visit the USGS National Research Program Web site at:
<http://water.usgs.gov/nrp/>

